



- 8** 1 Is there bread on a plate?  
Yes, there is.  
2 Is there juice in a glass?  
No, there isn't.  
3 Are there eggs in a bowl?  
Yes, there are.  
4 Are there serviettes under the forks?  
No, there aren't.

### Speaking

- 1** 1 1 c 2 b 3 e 4 d 5 a  
2 1 c 2 b 3 a 4 d 5 e
- 2** 1 Can I borrow, or a pink one  
2 I left it  
3 Who knows  
4 We're on  
5 When's the  
6 How do you spell

## # UNIT 1

### Vocabulary – page 8

- |                     |                  |
|---------------------|------------------|
| <b>1</b> 1 car park | 5 zebra crossing |
| 2 roundabout        | 6 traffic light  |
| 3 bank              | 7 town square    |
| 4 post office       | 8 playground     |
- 2** 1 bus stop 4 roundabouts  
2 stop sign 5 corner  
3 bridge
- 3** 1 amusement park 4 town square  
2 market 5 corner  
3 sights 6 factory
- 4** Accept all logical and grammatically correct answers.

### Grammar – page 9

- |               |       |
|---------------|-------|
| <b>1</b> 1 an | 4 any |
| 2 some        | 5 The |
| 3 a           |       |
- 2** 1 many 3 many  
2 much 4 much
- 3** 1 any 3 many  
2 a 4 an
- 4** 1 Yes, there are. 3 No, there aren't.  
2 No, there isn't. 4 Yes, there is.
- 5** 1 How much 4 How many  
2 How many 5 How many  
3 How much  
1 c 2 d 3 a 4 e 5 b

- |               |        |
|---------------|--------|
| <b>6</b> 1 an | 4 many |
| 2 the         | 5 any  |
| 3 a           |        |

### Speaking

- |                |              |
|----------------|--------------|
| <b>7</b> 1 get | 4 It's got   |
| 2 Try          | 5 Is it hard |
| 3 recommend    | 6 not at all |

### Vocabulary – page 10

- |                           |                  |
|---------------------------|------------------|
| <b>1</b> 1 go ice skating | 5 go camping     |
| 2 exercise                | 6 take a trip    |
| 3 paint                   | 7 go sightseeing |
| 4 go bowling              |                  |
- It's fun to **explore** new places.
- 2** 1 d 2 c 3 e 4 a 5 b
- |                       |               |
|-----------------------|---------------|
| <b>3</b> 1 see a show | 4 go abroad   |
| 2 join a group        | 5 order pizza |
| 3 take tours          |               |
- |                       |                |
|-----------------------|----------------|
| <b>4</b> 1 take tours | 4 go bowling   |
| 2 explore             | 5 hike         |
| 3 go out              | 6 join a group |

- 5** Accept all logical and grammatically correct answers.

### Grammar – page 11

- |                             |                         |
|-----------------------------|-------------------------|
| <b>1</b> 1 often, take      | 4 sometimes, hike       |
| 2 goes, every week          | 5 never, watches        |
| 3 exercises, in the evening | 6 order, at the weekend |
- 2** 1 goes 4 cries  
2 don't do 5 doesn't work  
3 doesn't open 6 paint
- 3** 1 Does your best friend often hike?  
2 Do you and your family take a trip every summer?  
3 What do you do at the weekend?  
4 When do you usually go out?  
Accept all logical and grammatically correct answers.
- |                  |                |
|------------------|----------------|
| <b>4</b> 1 visit | 6 take         |
| 2 do ... do      | 7 has          |
| 3 look           | 8 doesn't walk |
| 4 want           | 9 goes         |
| 5 don't live     |                |

### Speaking

- |                      |        |
|----------------------|--------|
| <b>5</b> 1 How often | 4 Who  |
| 2 Where              | 5 stay |
| 3 What               |        |

### Writing – page 12

- 1** 1 C 2 B 3 O 4 B 5 B
- 2** 1 e 2 d 3 a 4 f 5 c 6 b

## Writing Plan – page 13

- 1 Accept all logical and grammatically correct answers.
- 2 Accept all logical and grammatically correct answers.

## Progress Check – page 14

### Vocabulary

- |                   |                 |
|-------------------|-----------------|
| 1 1 sights        | 3 paint         |
| 2 playground      | 4 go abroad     |
| 2 1 e 3 g 5 a 7 b |                 |
| 2 d 4 h 6 f 8 c   |                 |
| 3 1 bridge        | 4 traffic light |
| 2 corner          | 5 go out        |
| 3 town square     | 6 explore       |
| 4 1 bathroom      | 6 snow          |
| 2 spoon           | 7 bakery        |
| 3 playground      | 8 roundabout    |
| 4 handbag         | 9 order pizza   |
| 5 hike            | 10 warm         |

### Dictation

5 

- 1 There's a roundabout near the post office and the bank.
- 2 There's a market in the town square.
- 3 Children have fun at playgrounds and at amusement parks.
- 4 We hike and go camping in the summer.
- 5 When I take a trip, I go sightseeing.

## Grammar – page 15

- |   |               |           |
|---|---------------|-----------|
| 6 1 any   | 5 an          |           |
| 2 much  | 6 some        |           |
| 3 some  | 7 How many    |           |
| 4 How much  |               |           |
| 7 1 much  | 4 a           |           |
| 2 many  | 5 any         |           |
| 3 an  | 6 some        |           |
| 8 1 How many  | 3 How many    |           |
| 2 How much  | 4 How much    |           |
| 9 1 stops   | 4 buy         |           |
| 2 don't go out  | 5 doesn't eat |           |
| 3 teaches   | 6 don't cook  |           |
| 10 1 Does your mother often go bowling?               |               |           |
| 2 Who do you usually sit next to in English lessons?  |               |           |
| 3 Where does your best friend live?                   |               |           |
| 4 When do you and your friends usually go out?        |               |           |
| Accept all logical and grammatically correct answers. |               |           |
| 11 1 is   | 4 is          | 6 walk    |
| 2 some  | 5 its         | 7 Laura's |
| 3 How many  |               |           |

## Translation

- 12 1 How often do you exercise?
- 2 There is a bus stop near my house.
- 3 Are there any car parks near the market?
- 4 I go out with my friends every Saturday.
- 5 Amy often goes ice skating in the winter.

## Standards Check – page 16

### Written Comprehension

- 1 1 F 2 F 3 T 4 F 5 T
- 2 1 in East Asia, between Russia and China
- 2 1,550,000 square kilometres
- 3 about 3.3 million
- 4 the first emperor of the Mongol Empire
- 5 Ulaanbaatar
- 6 at least two weeks

### Written Production

- 3 Accept all logical and grammatically correct answers.

## Oral Comprehension – page 17

4 

- Beth:** Hi, Tom.  
**Tom:** Oh, hi, Beth. What's new?  
**Beth:** Come look at this website. There are some interesting facts here about how people get around town all over the world.  
**Tom:** Hmm. This is interesting. In Delhi, India, there's a women's only section of the train.  
**Beth:** Really, why?  
**Tom:** I guess that gives them protection from crime.  
**Beth:** That's a good idea. What else is there?  
**Tom:** In Vienna, public transport is completely free.  
**Beth:** What! People don't pay for public transport there?  
**Tom:** No, sorry, I'm wrong. According to this website, you buy a ticket, but you don't validate it. That means, you don't put it in a ticket machine when you enter or leave the station.  
**Beth:** I hope everyone's honest in Vienna.  
**Tom:** Well, in Tallinn, Estonia, it doesn't matter, because public transport is definitely free there. But not for everyone – only for residents of Tallinn. Visitors pay to use public transport.  
**Beth:** I guess that's because residents pay the city for all their services.  
**Tom:** I guess so. Ah, this one's my favourite. It's a machine at train stations in San Francisco with library books.  
**Beth:** What a good idea. So you can get something to read for your train ride.  
**Tom:** That's right. And when you finish a book, you return it to the machine.  
**Beth:** I hope they do that here, too. I love reading on the train.  
**Tom:** Me, too!

- |          |                 |
|----------|-----------------|
| 1 Vienna | 3 San Francisco |
| 2 Delhi  | 4 Tallinn       |

## Oral Production

5 1 d 2 e 3 a 4 c 5 b

## # UNIT 2

### Vocabulary – page 18

- 1** 1 glue 4 paintbrush  
2 compass 5 map  
3 whiteboard 6 tablet
- 2** 1 paints 4 projector  
2 scissors 5 laptop  
3 calculator
- 3** 1 c 2 b 3 e 4 d 5 f 6 a
- 4** 1 microscope / textbook 4 projector  
2 scissors 5 compass  
3 whiteboard

### Grammar – page 19

- 1** 1 are talking 4 is wearing  
2 is writing 5 is opening  
3 are solving
- a Helen and Janice d Suzie  
b Max and Jimmy e Leo  
c Mrs Smith
- 2** 1 are wearing 4 isn't walking  
2 isn't using 5 is sitting  
3 aren't doing
- 3** 1 are using 6 are doing  
2 aren't sending 7 isn't singing  
3 are ... doing 8 is answering  
4 are watching 9 is making  
5 is wearing
- 4** 1 Are your friends talking right now?  
2 Is your teacher speaking to the class now?  
3 What colour pen are you using right now?  
4 Who are you sitting next to at the moment?  
Accept all logical and grammatically correct answers.

### Speaking

- 5** 1 I'm looking at 4 How about  
2 I need 5 What's the  
3 How much

## Vocabulary – page 20

**1**

t	h	e	l	i	c	o	p	t	e	r	n
a	a	s	c	o	o	t	e	r	t	k	y
e	f	x	l	b	j	t	v	b	m	l	t
r	u	l	i	o	t	n	s	l	x	l	j
o	r	d	j	r	r	d	g	h	d	t	k
p	n	x	b	k	u	r	j	b	i	r	v
l	y	l	l	q	g	l	y	r	b	p	k
a	g	d	x	t	l	d	p	t	t	q	z
n	m	p	b	d	z	t	j	r	r	j	k
e	y	l	v	l	w	d	b	p	d	a	m
g	x	l	z	b	r	z	d	x	j	d	m

- 1** 1 helicopter 5 tram  
2 scooter 6 taxi  
3 aeroplane 7 lorry  
4 ship
- 2** 1 underground 4 taxi  
2 boats 5 train  
3 minivan 6 electric bikes
- 3** 1 b 2 d 3 e 4 a 5 c
- 4** 1 sail; boat 3 ride; scooter  
2 take; train 4 drive; minivan
- 5** 1 helicopter 4 motorbike  
2 ferry / ship 5 minivan  
3 train / tram

### Grammar – page 21

- 1** 1 fly 4 is riding  
2 aren't sitting 5 isn't buying  
3 don't ... have
- 2** 1 isn't travelling 4 doesn't ride  
2 is choosing 5 aren't waiting  
3 tidies
- 3** 1 at night 4 rarely  
2 right now 5 today  
3 four times a week
- 4** 1 Do ... visit 6 is paying  
2 like 7 cost  
3 am standing 8 don't think  
4 aren't buying 9 wants  
5 are waiting



## Written Production

**3** Accept all logical and grammatically correct answers.

## Oral Comprehension – page 27

**4** 

Good afternoon. As you know, today we are starting our projects on transport. Do you know who you are working with? Good! A list is going around the class right now. Please write the name of your partner and the type of transport for your project.

In your projects, I want you to include three pieces of information. Are you writing this down? The first is this – the name of the inventor and which country it comes from. Secondly, you must explain how it works. For example, does it use electricity, like electric cars, wind, like sailing ships or does it move with human energy, like bicycles? Finally, you should include information about its function. Does it transport people or things? Do people still use it? And of course, I am expecting pictures because this project is for our class presentation. I know that Pete and Tom are making a model of theirs. That's a great idea! They chose a Viking ship. If a model sounds hard, you can create a nice picture using paints and a paintbrush, or cut out photographs with scissors and stick them onto your project with glue. By the way, please don't bring your personal laptops to class. You can use school laptops to find information. Remember to save any work on your flash drives. Mr Jones in room 32 can give you one. Is everything clear?

- |             |           |
|-------------|-----------|
| 1 transport | 5 picture |
| 2 inventor  | 6 laptops |
| 3 country   | 7 32      |
| 4 works     |           |

## Oral Production

**5** 1 b 2 c 3 a 4 c 5 a

## # UNIT 3

### Vocabulary – page 28

- 1** **Female:** daughter, wife, niece, stepmother  
**Male:** grandson, nephew, stepfather, husband
- 2**
- |            |               |
|------------|---------------|
| 1 Ella     | 6 Ron         |
| 2 Tom      | 7 Ron, Mia    |
| 3 Lucy     | 8 Ella, Lucy  |
| 4 Ann      | 9 Ben         |
| 5 Tom, Ben | 10 Fred, Sara |
- 3**
- |              |                |
|--------------|----------------|
| 1 stepfather | 4 wife         |
| 2 daughter   | 5 stepdaughter |
| 3 stepson    | 6 stepmother   |

### 4 Possible answers

- 1 Sam is Ross' and Meg's stepfather.
- 2 Bella is Ali's stepmother.
- 3 Ross is Sam's stepson.
- 4 Meg is Sam's stepdaughter.
- 5 Ali is Bella's stepdaughter.
- 6 Sam is Bella's husband.

### Grammar – page 29

- 1**
- |                |                 |
|----------------|-----------------|
| 1 There wasn't | 4 There were    |
| 2 There were   | 5 There weren't |
| 3 There wasn't | 6 There was     |
- 2**
- 1 Were there two sofas? No, there weren't.
  - 2 Was there a desk? Yes, there was.
  - 3 Were there any shelves? Yes, there were.
  - 4 Was there any paper? Yes, there was.
  - 5 Was there a computer? No, there wasn't.
  - 6 Were there any CDs? No, there weren't.
- 3**
- |                |              |
|----------------|--------------|
| 1 there were   | 5 There were |
| 2 there was    | 6 There was  |
| 3 there were   | 7 there were |
| 4 there wasn't |              |

### Speaking

**4** 1 e 2 a 3 d 4 c 5 b

### Vocabulary – page 30

- 1**
- |           |               |
|-----------|---------------|
| 1 artist  | 5 waiter      |
| 2 dentist | 6 firefighter |
| 3 cleaner | 7 mechanic    |
| 4 singer  | 8 hairdresser |
- 2**
- |                  |             |
|------------------|-------------|
| 1 musician       | 5 actor     |
| 2 businessperson | 6 astronaut |
| 3 nurse          | 7 author    |
| 4 pilot          |             |
- 3**
- |              |               |
|--------------|---------------|
| 1 tour guide | 4 musician    |
| 2 driver     | 5 salesperson |
| 3 author     | 6 mechanic    |

**4** Accept all logical and grammatically correct answers.

### Grammar – page 31

- 1**
- |            |              |
|------------|--------------|
| 1 bought   | 6 built      |
| 2 stopped  | 7 began      |
| 3 saw      | 8 took       |
| 4 did      | 9 identified |
| 5 happened | 10 made      |
- 2**
- |                   |                          |
|-------------------|--------------------------|
| 1 wrote, received | 4 learnt / learned, flew |
| 2 started, was    | 5 worked, met            |
| 3 appeared, got   |                          |
- 1 b 2 e 3 a 4 c 5 d

- 3** 1 wanted  
2 took  
3 started  
4 began  
5 became

- 6 called  
7 put  
8 bought  
9 used

## Speaking

- 4** 1 know about  
2 What do you  
3 isn't for me  
4 you'd like that  
5 try something new

## Writing – page 32

- 1** 1 so  
2 and  
3 or  
4 but
- 2** 1 d, so  
2 c, and  
3 a, but  
4 b, or
- 3** 1 and  
2 and  
3 or  
4 so  
5 so

## Writing Plan – page 33

- 1** Accept all logical and grammatically correct answers.  
**2** Accept all logical and grammatically correct answers.

## Progress Check – page 34

### Vocabulary

- 1** 1 nurse, dentist  
2 musician, author, artist  
3 grandson, husband, stepson
- 2** 1 husband  
2 salesperson  
3 firefighter  
4 wife  
5 son  
6 businessperson  
7 parents
- 3** 1 d 2 e 3 b 4 c 5 a
- 4** 1 wife  
2 cleaner  
3 nephew  
4 astronaut  
5 tour guide  
6 grandson  
7 hairdresser  
8 mechanic
- 5** 1 paints  
2 shower  
3 park  
4 hiked  
5 singer  
6 factory  
7 takes  
8 going sightseeing  
9 stepfather  
10 flash drive

## Dictation

**6** 

- 1 His stepsons became actors.  
2 There was a singer at the event.  
3 The tour guide showed us the sights.  
4 My grandparents gave me a bicycle for my birthday.  
5 Were there any nurses to help you?

## Grammar – page 35

- 7** 1 There was  
2 There weren't  
3 Was there  
4 There wasn't  
5 Were there  
6 There wasn't  
7 There were  
8 Was there
- 8** 1 drove  
2 went out  
3 stopped  
4 washed  
5 studied  
6 made  
7 saw  
8 travelled
- 9** 1 explored  
2 had  
3 tidied  
4 got up  
5 met  
6 sent
- 10** 1 has got  
2 any  
3 visited  
4 my  
5 Are you  
6 cousins'  
7 studies  
8 How much  
9 Was there  
10 aren't leaving

## Translation

- 11** 1 There was one / a salesperson in the shop.  
2 My daughter went to the dentist.  
3 The singer sang a beautiful song.  
4 Were there any musicians at the party?  
5 Adam's grandparents took him to New York.

## Standards Check – page 36

### Written Comprehension

- 1** 1 122 centimetres  
2 tablet  
3 Scotland  
4 supermarket  
5 Japan  
6 SoftBank
- 2** 1 emotions  
2 weather  
3 help  
4 knife  
5 sad

### Written Production

- 3** Accept all logical and grammatically correct answers.

## Oral Comprehension – page 37

**4** 

- Carl:** Emma, is this a picture of your grandfather?  
**Emma:** It's a picture of my dad's grandfather, George.  
**Carl:** That's a really strange uniform. What job did he have?  
**Emma:** He was a town crier.  
**Carl:** A town crier? What's that?  
**Emma:** Well, it's a job from hundreds of years ago. There weren't any newspapers in those days. So when there was important news or information, a town crier stood in the town square and read it to people. He shouted. "Oyez, oyez!"  
**Carl:** What does *oyez* mean?  
**Emma:** It means *hear* or *listen*. When he shouted that, people came out of their homes to hear the news. He read the message in a very loud voice.  
**Carl:** Wow! That was a cool job! So is that what George did?  
**Emma:** Well, not exactly. After people started reading newspapers, the job of town criers changed. George only appeared at special events in the town. He wore a red and gold jacket and hat.  
**Carl:** What did he say?  
**Emma:** He read information about the events. He sometimes introduced musicians or singers, or read the results of games or competitions.  
**Carl:** Did women become town criers, too?  
**Emma:** Yes, many town criers were women. Some town criers today are women, too.  
**Carl:** So there are still town criers today!  
**Emma:** Yes! After the birth of each of Prince William and Kate's babies, for example, there was a male town crier in the street outside the hospital. He read the good news.

- |               |           |
|---------------|-----------|
| 1 grandfather | 4 hat     |
| 2 town square | 5 singers |
| 3 listen      | 6 a baby  |

## Oral Production

- 5** 1 1 Was there anything good 3 was it about  
 2 Was it
- 2 1 do you know about 3 What else  
 2 do you do there 4 I'd like to try

## # UNIT 4

### Vocabulary – page 38

- 1** 1 slip 4 ambulance  
 2 injure 5 kill  
 3 first-aid kit
- 2** 1 dangerous 4 hurt  
 2 safe 5 prevented  
 3 fell 6 accident
- 3** 1 b 2 c 3 a  
 1 first-aid kit 3 call for help  
 2 broke his leg

### 4 Possible answers

- 1 there was an accident  
 2 hurt / broke her leg  
 3 take a first-aid kit  
 4 hurt / broke his leg  
 Accept all logical and grammatically correct answers.

### Grammar – page 39

- 1** 1 didn't break, leg 4 didn't call, help  
 2 didn't get, mountain 5 didn't take, first-aid kit  
 3 didn't prevent, accident
- 2** 1 didn't compete 3 didn't work  
 2 didn't discover 4 didn't injure  
 1 c 2 a 3 b 4 d
- 3** 1 a She went to the beach yesterday.  
 b She didn't watch television all day yesterday.  
 2 a He didn't work this morning.  
 b He broke his leg yesterday.  
 3 a They received an emergency call a few minutes ago.  
 b They didn't have time to drink their coffee.
- 4** 1 became 5 didn't stop  
 2 took 6 didn't climb  
 3 didn't have 7 began  
 4 didn't receive 8 worked

### Speaking

- 5** 1 Here's something 4 I can't  
 2 believe you 5 happened  
 3 here's something else

### Vocabulary – page 40

- 1** 1 win 4 carry  
 2 lie down 5 rescue  
 3 arrive
- 2** 1 b 2 a 3 c 4 a 5 b 6 c 7 a
- 3** 1 trained 4 rescued  
 2 forget 5 held  
 3 competed

### 4 Possible answers

- 1 His wife competed in a tennis competition.  
 2 I got lost in the forest.  
 3 Our team won the game.  
 4 Mum lay down on the sofa.  
 5 My grandparents arrived at 8.30.

### Grammar – page 41

- 1** 1 Did ... compete 4 did ... get  
 2 did ... arrive 5 did ... give up  
 3 Did ... carry  
 1 d 2 a 3 c 4 e 5 b



## Oral Comprehension – page 47

**4** 

**Rick:** Welcome to Travel Light. Today, we're talking about visiting dangerous places. We've got Katie from Devon on the line. Hi, Katie. What dangerous place did you visit?  
**Katie:** Hi, Rick. Last year, I visited Victoria Falls in Livingstone, Zambia. I swam in the Devil's Pool.  
**Rick:** What's that?  
**Katie:** It's a natural pool at the top of Victoria Falls. We swam in the Zambezi River to get there. Then, when we jumped in, the water pushed us close to the waterfall. We lay down and watched the waterfall 108 metres below.  
**Rick:** Wow! What prevented you from falling down into the waterfall?  
**Katie:** The river waters are strong, but there's a rocky wall just before the waterfall. You can only visit between September and December. At that time, the water is usually low. During the rest of the year, it's not safe to visit.  
**Rick:** Sounds exciting. Thanks Katie. Our next caller is Rob from Sunderland. Hi Rob.  
**Rob:** Hi, Rick! I cycled down the Death Road in Bolivia. It's a road from La Paz to Coroico, about 60 kilometres long.  
**Rick:** Why is it called Death Road?  
**Rob:** It's a very dangerous mountain road. In 2009, a new road opened, but until then, about 300 people lost their lives here every year in accidents.  
**Rick:** Gosh! Did you have any accidents?  
**Rob:** I fell and hurt my leg. Then, I saw a lorry in front of me. I ran out of the way just in time. It destroyed my bike.  
**Rick:** Sorry to hear, but I'm glad you're here to tell the story! Our next caller is Brad.

1 b 2 b 3 c 4 c 5 a 6 c

## Oral Production

**5** 1 b 2 a 3 c 4 b 5 c

## # UNIT 5

### Vocabulary – page 48

**1**

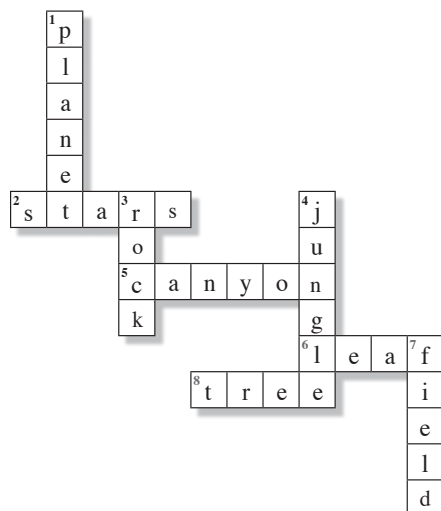

**2** 1 sky  
2 grass  
3 path  
4 rainforest

5 ground  
6 countryside  
7 rocks

**3** 1 trees  
2 sky  
3 countryside

4 ground  
5 planet

## Grammar

**1** 1 were  
2 was  
3 were

4 was  
5 was

**2** 1 c, was walking  
2 a, were walking  
3 d, was looking, was flying  
4 b, were sailing, were building

## page 49

**3** 1 was visiting  
2 were walking  
3 was telling  
4 were shooting

5 were reaching  
6 was falling  
7 was ... watching  
8 was happening

**4** Accept all logical and grammatically correct answers.

## Speaking

**5** 1 Both pictures are of  
2 in the first picture  
3 in the second picture

4 There are  
5 there aren't

## Vocabulary – page 50

**1** 1 g 2 b 3 d 4 f 5 c 6 a 7 e

**2** 1 lost  
2 dropped  
3 enjoyed

4 laughed  
5 believed

**3** Accept all logical and grammatically correct answers.

## Grammar – page 51

**1** 1 wasn't hiking  
2 weren't crying  
3 wasn't watching

4 weren't falling  
5 weren't swimming

**2** 1 Derek wasn't running towards his mother. He was playing with Mia.  
2 Jane and Bess weren't sending messages. They were eating sandwiches.  
3 Mia wasn't crying. She was smiling.  
4 Simon and Dave weren't walking along a path. They were climbing up a tree.

- 3** 1 Was Linda talking to her children? No, she wasn't. / No, she was talking on the phone.  
 2 Were Jane and Bess sitting on a rock? No, they weren't. / No, they were sitting on a rug.  
 3 What was Mia throwing? Mia was throwing a ball.  
 4 Were Simon and Dave lying on the grass? No, they weren't. / No, they were climbing up a tree.
- 4** 1 was ... planning                      4 weren't wearing  
 2 was getting                                5 was ... doing  
 3 weren't carrying                        6 was camping

## Speaking

- 5** 1 Were you sleeping                      3 were you sitting next to  
 2 were you doing                        4 was your friend wearing

## Writing – page 52

- 1** 1 Finally                                      3 Next  
 2 First, Then                                4 after that
- 2** 1 First                                        3 After that / Next / Then  
 2 Then / Next / After that              4 Finally
- 3** 1 First                                        3 After that  
 2 Then                                        4 Finally

## Writing Plan – page 53

- 1** Accept all logical and grammatically correct answers.  
**2** Accept all logical and grammatically correct answers.

## Progress Check – page 54

### Vocabulary

- 1** 1 leaf                                        3 drop  
 2 sky
- 2** 1 make a mistake                        5 ground  
 2 enjoyed                                    6 canyon  
 3 believe                                    7 rainforest  
 4 runs towards
- 3** 1 d    2 b    3 a    4 c
- 4** 1 remember                                4 suggest  
 2 lose                                        5 believe  
 3 climb up
- 5** 1 a    3 a    5 a    7 c    9 a  
 2 c    4 b    6 b    8 b    10 b

### Dictation

**6** 

- 1 My friend was running towards me and smiling.  
 2 They were lying on the ground and looking at the stars.  
 3 Ann wasn't enjoying the party.  
 4 Why were you crying?  
 5 At 6.00, we were hiking in the rainforest.

## Grammar – page 55

- 7** 1 wasn't sleeping                        4 wasn't smiling  
 2 were having                            5 were flying  
 3 was watching
- 8** 1 Why was the baby crying last night?  
 2 Were Katy and James playing football yesterday evening?  
 3 What was Dave watching last night?  
 4 Where were you and your friends sitting?  
 5 Were you talking to your cousin yesterday?  
 1 c    2 d    3 a    4 e    5 b
- 9** 1 were ... hiking                        4 was climbing up  
 2 were having                            5 wasn't looking  
 3 weren't thinking                        6 was listening
- 10** 1 didn't go                                6 much  
 2 wasn't climbing                        7 How many  
 3 Is Josie going out                      8 has got  
 4 broke                                      9 Lily's  
 5 don't believe                            10 There weren't

## Translation

- 11** 1 Were the women climbing up the mountain?  
 2 The dog was running towards the cat.  
 3 The film was funny and all the people were laughing.  
 4 Leaves were falling from the trees.  
 5 The children weren't walking on the path.

## Standards Check – page 56

### Written Comprehension

- 1** 1 Ngurunderi's wives  
 2 Sauweteiau, Ngurunderi's wives  
 3 Roraimenu  
 4 Sauweteiau  
 5 Ngurunderi
- 2** 1 a tsunami  
 2 Because they discovered a huge number of rocks on the ocean floor.  
 3 They became rocks.  
 4 by ferry or aeroplane

### Written Production

- 3** Accept all logical and grammatically correct answers.

## Oral Comprehension – page 57

### 4

**Annie:** Hi, George. Guess where I'm going this summer. It's somewhere hot and dry!

**George:** The Grand Canyon?

**Annie:** No, Australia's Great Sandy Desert, on an adventure tour!

**George:** Cool! Before you go, I suggest you watch *Miracle in the Desert*.

**Annie:** What's that?

**George:** It's a documentary about a man called Robert Bogucki. He's from Alaska, and he tried to cycle across that desert. It was impossible on the sand, so he started walking. He left his bike, and he didn't have much food or water, but he had a map. At first, he was walking about 20 kilometres a day and he was doing well. However, one day, he made a mistake and lost the path.

**Annie:** Oh! How did he stay alive?

**George:** Well, Robert was a firefighter with medical training. He knew that people can live without food for a long time, but not without water. He was also interested in how Aborigines lived and remembered reading how to find water deep in the sand or under rocks.

**Annie:** Did he get across the desert in the end?

**George:** Sixteen days after Robert began his trip, the police drove out to the desert to find him. However, they gave up after 12 days. No one believed he was alive, but Robert's family sent another rescue team. Eventually, a helicopter saw him. He was drinking water from a rock pool. That was his 43rd day in the desert!

1 c 2 b 3 a 4 b 5 c

## Oral Production

- 5** 1 What are the pictures of?  
2 Can you describe them?  
3 What are the differences?  
4 Are they pictures of the same place?

## # UNIT 6

### Vocabulary – page 58

- |                      |                |
|----------------------|----------------|
| <b>1</b> 1 get a job | 4 get divorced |
| 2 grow up            | 5 are born     |
| 3 get married        | 6 have a baby  |
| <b>2</b> 1 celebrate | 4 moved in     |
| 2 graduate           | 5 grow up      |
| 3 fell in love       |                |
| <b>3</b> 1 was born  | 5 got a job    |
| 2 left school        | 6 separated    |
| 3 graduated          | 7 got divorced |
| 4 got married        | 8 died         |

- 4** Accept all logical and grammatically correct answers.

## Grammar

- |                |         |         |
|----------------|---------|---------|
| <b>1</b> 1 can | 3 can   | 5 can't |
| 2 can't        | 4 can't | 6 can   |

### page 59

- 2** 1 Can you cook spaghetti bolognese?  
2 Can your grandparents make video clips?  
3 Can you read novels in English?  
4 Can your best friend sing well?  
Accept all logical and grammatically correct answers.

### 3 Possible answers

- 1 I could play computer games two years ago.  
2 I couldn't read when I was a baby.  
3 I could ride a bicycle at the age of six.  
4 I couldn't use a calculator when I was three years old.  
5 I couldn't surf the web when I was a baby.  
Accept all logical and grammatically correct answers.

- 4** 1 Could American women vote before 1920?  
No, they couldn't.  
2 Could women participate in the Olympic Games in 1904?  
Yes, they could.  
3 Could women study at Harvard University in 1967?  
No, they couldn't.  
4 Could women join the US military in 1950?  
Yes, they could.

- |                |         |
|----------------|---------|
| <b>5</b> 1 can | 4 can   |
| 2 could        | 5 can't |
| 3 couldn't     |         |

## Speaking

- |                        |             |
|------------------------|-------------|
| <b>6</b> 1 play, can't | 3 make, can |
| 2 Could, couldn't      | 4 well, now |

## Vocabulary – page 60

<b>1</b>	<b>Jobs</b>	<b>Police activities</b>
	detective	arrest
	police officer	catch
	<b>Crimes</b>	<b>Evidence</b>
	robbery	fingerprint
	murder	footprint

- 2** 1 b 2 e 3 a 4 f 5 d 6 c
- 3** 1 investigate 4 weapon  
2 evidence 5 examine  
3 footprints 6 catch
- 4** 1 police officer, arrested / caught  
2 robbery, stole  
3 detective, footprints / evidence  
4 murdered, weapon



## Oral Comprehension – page 67

**4** 

OK, everyone, listen. We have a new murder case and we need your help solving it. At 4 o'clock this morning, someone murdered a woman in the park on Rose Street. We found the murder weapon – a knife – in the grass and there were footprints on the ground. Two people were walking near the park at 2.15 am. They saw a man standing at the entrance to the park. We believe this man is the criminal. Now, write this down. He was about 35 years old, 1.80 metres tall and he had short brown hair. He was wearing blue jeans and a black shirt. According to the footprints, we think he weighs about 80 kilos and he was wearing size 8 trainers at the time of the murder. You must look for a man of that description. Start looking right now. Good luck!

- |                       |                           |
|-----------------------|---------------------------|
| 1 murder              | 5 1.80 metres             |
| 2 park on Rose Street | 6 80 kilos                |
| 3 knife               | 7 short brown             |
| 4 35 years            | 8 blue jeans, black shirt |

## Oral Production

**5** 1 a 2 b 3 c 4 b 5 a

## # UNIT 7

### Vocabulary – page 68

**1**  pretty unique frightening narrow modern old-fashioned

- |                 |               |
|-----------------|---------------|
| 1 old-fashioned | 4 frightening |
| 2 modern        | 5 unique      |
| 3 pretty        | 6 narrow      |
- 2**
- |               |            |
|---------------|------------|
| 1 modern      | 4 wide     |
| 2 normal      | 5 trendy   |
| 3 interesting | 6 horrible |
- 3**
- |                      |                      |
|----------------------|----------------------|
| wonderful – horrible | interesting – boring |
| tiny – huge          | thin – thick         |
- |             |                       |
|-------------|-----------------------|
| 1 tiny      | 4 horrible            |
| 2 wonderful | 5 thick, thin         |
| 3 huge      | 6 interesting, boring |

**4** Accept all logical and grammatically correct answers.

### Grammar – page 69

- 1**
- |                 |                       |
|-----------------|-----------------------|
| 1 wider than    | 4 worse than          |
| 2 tinier than   | 5 fatter than         |
| 3 stronger than | 6 more difficult than |
- 2**
- |                       |                     |
|-----------------------|---------------------|
| 1 longer than         | 4 easier than       |
| 2 more beautiful than | 5 more unusual than |
| 3 nicer than          |                     |
- 3**
- |                         |                         |
|-------------------------|-------------------------|
| 1 thinner than          | 4 trendier than         |
| 2 bigger than           | 5 more adventurous than |
| 3 more frightening than |                         |

## 4 Possible answers

- Lupita Nyong'o's hair is darker than Elizabeth Olsen's hair.
- Scarlett Johansson is younger than Lupita Nyong'o.
- Elizabeth Olsen is taller than Scarlett Johansson.
- Scarlett Johansson is shorter than Lupita Nyong'o.
- Scarlett Johansson is older than Elizabeth Olsen.
- Elizabeth Olsen's hair is lighter than Lupita Nyong'o's hair.

## Speaking

- 5**
- |                    |                       |
|--------------------|-----------------------|
| 1 and he isn't     | 4 all the other girls |
| 2 than, but she is | 5 Her hair is         |
| 3 His clothes are  |                       |

## Vocabulary – page 70

- 1** Tick: 1, 2, 4, 6, 8
- 2**
- |           |             |
|-----------|-------------|
| 1 polite  | 5 slow      |
| 2 noisy   | 6 difficult |
| 3 famous  | 7 nervous   |
| 4 worried |             |
- 3**
- |             |          |
|-------------|----------|
| 1 quick     | 3 rude   |
| 2 difficult | 4 simple |
- 4** 1 c 2 a 3 h 4 b 5 d 6 f 7 g 8 e
- 5** Accept all logical and grammatically correct answers.

## Grammar – page 71

- 1**
- |         |          |        |
|---------|----------|--------|
| 1 yours | 3 theirs | 5 ours |
| 2 hers  | 4 his    |        |
- 2**
- |        |          |        |     |     |
|--------|----------|--------|-----|-----|
| 1 b    | 2 e      | 3 a    | 4 c | 5 d |
| a ours | c theirs | e mine |     |     |
| b his  | d hers   |        |     |     |
- 3**
- |        |        |         |
|--------|--------|---------|
| 1 mine | 3 Her  | 5 hers  |
| 2 My   | 4 Your | 6 yours |

## Speaking

- 4** 1 a 2 b 3 a 4 a 5 b

## Writing – page 72

- 1**
- Jack is repairing the fridge.
  - The grey shoes are mine.
  - The baby laughed happily.
  - His black shirt is really trendy.
  - Your sister sings very well.
- 2**
- |               |                   |
|---------------|-------------------|
| 1 very stormy | 3 work hard       |
| 2 we stay     | 4 beautiful place |

## Writing Plan – page 73



- Accept all logical and grammatically correct answers.
- Accept all logical and grammatically correct answers.

## Progress Check – page 74

### Vocabulary

- 1** 1 polite                      6 calm  
2 quick                        7 modern  
3 huge                         8 boring  
4 quiet                         9 horrible  
5 difficult                    10 narrow
- 2** 1 b    2 c    3 a    4 b    5 a    6 c    7 c
- 3** 1 lucky                        4 careful  
2 angry                        5 thick  
3 difficult                    6 trendy
- 4** 1 steal                         6 normal  
2 drop                         7 grow up  
3 forget                        8 grass  
4 firefighter                 9 rescue  
5 go bowling                10 stepson

### Dictation

- 5**  
- 1 Your dress is prettier than hers.  
2 The yellow sweater is thicker than the blue one.  
3 This maths test was more difficult than the one last month.  
4 I think your project is more interesting than mine.  
5 This road is narrower than the other roads.

### Grammar – page 75

- 6** 1 better than                      4 stronger than  
2 prettier than                    5 taller than  
3 more interesting than
- 7** 1 noisier than                      4 friendlier than  
2 luckier than                      5 bigger than  
3 more modern than              6 more athletic than
- 8** 1 his                      3 yours                      5 mine  
2 Hers                    4 theirs
- 9** 1 yours                    3 his                      5 Their  
2 her                      4 ours
- 10** 1 didn't take                      6 were talking  
2 don't like                        7 theirs  
3 worse than                      8 am having  
4 must                              9 quieter than  
5 some                              10 there are

### Translation

- 11** 1 The brown shoes are more old-fashioned than the black shoes.  
2 He is noisier than the other boys.  
3 Exercise one is simpler than exercise two.  
4 Their flat is more modern than ours.  
5 Your clothes are trendier than mine.

## Standards Check – page 76

### Written Comprehension

- 1** 1 e    2 c    3 d    4 a
- 2** 1 hungry  
2 are coming out of the rainforest and making contact  
3 more difficult (than it was in the past)  
4 clothes and cooking equipment  
5 help these amazing tribes

### Written Production

- 3** Accept all logical and grammatically correct answers.

### Oral Comprehension – page 77

**4** 

**Interviewer:** Hello. I'm Gail Reese and I'm outside Windsor Castle near London. As you know, Prince Harry and Meghan Markle got married here today and we saw the wedding on a huge screen outside. Thousands of excited people are still standing around the castle. Let's talk to some of them now ... Hello, what's your name?

**Ava:** Ava Lewis.

**Interviewer:** Where are you from, Ava?

**Ava:** I'm from Canada. I arrived here yesterday. I'm a big fan of the Royal Family and I really wanted to be here today to celebrate with people in the UK.

**Interviewer:** Did you see Meghan and Harry when they left the castle and passed along the street?

**Ava:** Oh, yes. Meghan looked at me! It was so exciting! She looked really calm, but I'm sure she was more nervous than she looked.

**Interviewer:** Yes, I'm sure she was.

**Ava:** Yes, and it's difficult to move to a new country and live with a royal family. She must make many changes to her life.

**Interviewer:** Absolutely! So what did you think of Meghan's dress?

**Ava:** Well, it was a pretty dress, but it was simpler than Kate's, the Duchess of Cambridge's, wedding dress at her wedding to Prince William in 2011.

**Interviewer:** I agree. Did you see any of the celebrities before they went into the church?

**Ava:** Yes. I saw many famous people, including George Clooney and his wife, Amal. It was wonderful!

- 1 got married there                      4 simpler than  
2 Canada                                    5 famous people / celebrities  
3 looked at her

### Oral Production

- 5** 1 c    2 f    3 a    4 b    5 d    6 e

## # UNIT 8

### Vocabulary – page 78

- 1** 1 a 2 b 3 a 4 a 5 b 6 b
- 2** 1 disagree 5 repair  
2 collect 6 return, keep  
3 donate 7 borrow, lend  
4 promised
- 3** Accept all logical and grammatically correct answers.

### Grammar – page 79

- 1** 1 isn't going to repair, is going to cut  
2 aren't going to take, are going to give  
3 is going to lend, isn't going to throw  
4 are going to volunteer, aren't going to work
- 2** 1 Are you going to help your parents this evening?  
2 Is your friend going to visit you later?  
3 Where are you and your family going to go in the summer?  
4 What are you going to do tomorrow?  
5 Is your mother going to go out with you next weekend?  
Accept all logical and grammatically correct answers.
- 3** 1 are ... going to give 5 are going to collect  
2 am not going to receive 6 are going to buy  
3 am going to participate 7 isn't going to give  
4 am going to donate 8 are going to go

### Speaking

- 4** 1  
1 b 2 d 3 a 4 c  
2  
1 b 2 e 3 c 4 a 5 d

### Vocabulary – page 80

- 1** 1 pick up 5 turn on  
2 pollute 6 plant  
3 clean up 7 throw out  
4 recycle
- 2** 1 buildings 5 road  
2 storm 6 TV  
3 shoe boxes 7 rain  
4 sugar
- 3** 1 waste 4 pick up  
2 throw out 5 reduce  
3 pollute
- 4** Accept all logical and grammatically correct answers.

### Grammar – page 81

- 1** 1 isn't buying 4 am not bringing  
2 are volunteering 5 are returning  
3 are celebrating 6 isn't leaving
- 2** 1 Are Jessie and Chris repairing the computer at 12:00?  
Yes, they are.  
2 Is Jessie visiting her grandma at 13:30?  
No, she isn't.  
3 Are Jessie and Ben finishing the science project at 14:00?  
Yes, they are.  
4 Is Jessie listening to Kate's history presentation at 17:30?  
Yes, she is.  
5 What time are Jessie and Lenny going out?  
At 20:00.
- 3** 1 are ... doing 5 is returning  
2 are cleaning up 6 am not taking  
3 are leaving 7 am having  
4 isn't staying

### Speaking

- 4** 1 an amazing city  
2 there are a lot of fun things to do here  
3 Like what  
4 yesterday we saw  
5 on the underground

### Writing – page 82

- 1** 1 yours 4 He  
2 its 5 mine  
3 hers
- 2** 1 her 4 ours  
2 It 5 my  
3 they
- 3** 1 My 4 their  
2 they 5 our  
3 its

### Writing Plan – page 83

- 1** Accept all logical and grammatically correct answers.  
**2** Accept all logical and grammatically correct answers.

### Progress Check – page 84

#### Vocabulary

- 1** 1 an ocean, a river  
2 food, electricity  
3 vegetables, trees  
4 your life, animals  
5 rubbish, old clothes  
6 projector, rug

2 1 c 2 f 3 e 4 b 5 a 6 d

3 1 promise 4 pick up  
2 bring 5 repair  
3 collect 6 reduce

4 1 agree 5 keep  
2 borrow 6 disagree  
3 finish 7 return  
4 recycle 8 preserve

5 1 b 3 a 5 c 7 b 9 b  
2 c 4 b 6 a 8 c 10 a

## Dictation

6  d

- 1 I'm going to turn off the TV soon.
- 2 Are you going to throw out your old phone?
- 3 The mechanic is repairing our car tomorrow.
- 4 How much money is Mike going to borrow?
- 5 I'm returning these books to the library tomorrow.

## Grammar – page 85

7 1 am going to finish 4 are going to donate  
2 isn't going to repair 5 Are ... going to participate  
3 Is ... going to destroy 6 isn't going to sell

8 1 Are ... going to help 4 are going to take  
2 is ... going to begin 5 am not going to join  
3 are going to eat 6 is going to meet

9 1 are taking 4 am not participating  
2 Are ... collecting 5 are ... spending  
3 is coming

10 1 I am volunteering at the animal shelter next Monday.  
2 Are you meeting Jamie for lunch tomorrow?  
3 Mr Clark isn't visiting the recycling centre this week.  
4 We aren't having an art lesson tomorrow.  
5 What is Dan bringing to the party tomorrow night?

11 1 are celebrating 6 could  
2 is going to buy 7 there is  
3 don't use 8 ours  
4 there was 9 any  
5 carried 10 are going to make

## Translation

12 1 The students are going to clean up the forest next week.  
2 Are you going to donate these old computers?  
3 What are you bringing to the party on Saturday?  
4 She isn't going to finish the project today.  
5 I'm not planting the trees tomorrow.

## Standards Check – page 86

### Written Comprehension

1 1 two or three 4 2,720 litres  
2 100 days 5 9.5 billion kilograms  
3 80 billion

2 1 Because fashion is changing all the time and they want to look trendy.  
2 They leave them at the back of their cupboard or throw them out.  
3 It uses a lot of water and pollutes rivers and oceans.  
4 To keep their clothes for a longer time, reduce waste and help to preserve the environment.

### Written Production

3 Accept all logical and grammatically correct answers.

### Oral Comprehension – page 87

4  d

**Len:** Hey, Emma. What are you doing? Why are you picking up that plastic bottle from the ground?

**Emma:** Do you know what usually happens to plastic bottles, Len? The rain washes them into rivers and then into the ocean.

**Len:** But you didn't drop the bottle on the ground, so it isn't your problem.

**Emma:** But you're wrong! Human rubbish is polluting our water and endangering sea animals. We all live on this planet, so we should all do something to help.

**Len:** I agree. But I'm not going to pick up other people's rubbish!

**Emma:** The problem is, people always wait for someone else to solve their problems. They should think about what they can do instead. By picking up just one piece of rubbish a day, you can make a huge difference.

**Len:** Seriously, Emma? One person isn't going to change anything.

**Emma:** I disagree, Len. About a year ago, I was on the beach with my cousins, Janet and Sarah, I picked up a plastic bottle. That gave them the idea to start a Clean-Up Day event. Now, their whole community cleans up the streets and park once a month. Last week, there was an article about the clean-up days in the newspaper and other people in our city are starting a similar event soon.

**Len:** Wow. So you really are making a difference!

**Emma:** Yes, I am. Hey, Len? Where are you going?

**Len:** That driver threw a plastic bag out of the window! I'm going to put it in the bin.

1 another person's 4 the clean-up days  
2 recycling rubbish 5 pick up rubbish  
3 Emma's cousins

### Oral Production

5 1 1 Would you mind 2 1 a good time  
2 What's the problem 2 is it there  
3 Certainly 3 like

## # UNIT 9

### Vocabulary – page 88

1 file monitor videogame keyboard printer mouse speakers

- |            |              |
|------------|--------------|
| 1 file     | 5 speakers   |
| 2 keyboard | 6 video game |
| 3 mouse    | 7 printer    |
| 4 monitor  |              |

2 1 f 2 a 3 e 4 c 5 b 6 d

3 1 screen 4 stream  
2 touchscreen 5 store  
3 code

4 Accept all logical and grammatically correct answers.

### Grammar

1 Accept all logical and grammatically correct answers.

### page 89

2 1 e 2 f 3 d 4 b 5 a 6 c

- |              |                |
|--------------|----------------|
| 1 will be    | 4 won't travel |
| 2 won't live | 5 will move    |
| 3 will have  | 6 will close   |

3 1 Will machines understand our thoughts?  
2 Will robots do all our jobs for us?  
3 Will people recycle all types of plastic?  
4 Will plastic pollution kill all sea animals?  
5 Will we build cities on artificial islands?

Accept all logical and grammatically correct answers.

4 1 Will ... become 4 won't be  
2 Will ... solve 5 will talk  
3 will finish

### Speaking

5 1 f 2 b 3 a 4 g 5 c 6 e 7 d

### Vocabulary – page 90

1 1 toothpaste  
2 brush  
3 pillow  
4 lamp  
5 kettle  
6 houseplant  
7 key  
8 hairdryer  
9 microwave

b	t	u	v	n	k	d	h	y	n	d	c
k	s	v	p	i	l	l	o	w	t	n	h
e	q	w	b	z	u	l	u	r	g	t	a
t	o	o	t	h	p	a	s	t	e	v	i
t	s	w	n	m	e	z	e	r	g	h	r
l	o	b	r	u	s	h	p	q	m	p	d
e	g	p	e	l	e	t	l	n	c	q	r
y	h	c	e	i	a	e	a	a	r	t	y
s	q	b	t	k	j	y	n	n	m	m	e
m	x	v	n	k	e	y	t	e	r	p	r
m	i	c	r	o	w	a	v	e	r	b	t

2 1 d 2 g 3 a 4 f 5 b 6 c 7 e

3 1 air conditioner 4 houseplant  
2 pillow 5 charger  
3 key 6 kettle

### 4 Possible answers

- There are four towels in the bathroom.
- There isn't any water in the kettle.
- He put his clothes in the washing machine.
- I need some shampoo to wash my hair.
- She has got a charger for her phone.
- We couldn't open the door with this key.

### Grammar – page 91

1 1 will turn on 4 won't go out  
2 need 5 will return  
3 doesn't repair 6 gives

2 1 put, microwave 4 hair, will look  
2 won't get, key 5 doesn't use, soap  
3 Houseplants, don't receive

3 1 get 6 will need  
2 will stop 7 continues  
3 don't find 8 will sell  
4 will ... get 9 don't produce  
5 continue 10 won't have

### Speaking

4 1 c 2 d 3 b 4 a

### Writing – page 92

1 1 b 2 c 3 c 4 a 5 b 6 a

2 1 gradually 4 store  
2 come down 5 fantastic  
3 tiny

### Writing Plan – page 93

1 Accept all logical and grammatically correct answers.  
2 Accept all logical and grammatically correct answers.

### Progress Check – page 94

#### Vocabulary

1 1 shampoo, soap  
2 washing machine, hairdryer  
3 memory card, external hard drive  
4 towel, toothbrush

2 1 c 2 e 3 a 4 f 5 b 6 d

3 1 c 2 d 3 a 4 f 5 b 6 e

4 1 printer 4 monitor  
2 rubbish bin 5 speakers  
3 file 6 video game

- 5 1 b 3 c 5 c 7 b 9 b  
2 b 4 a 6 a 8 c 10 a

## Dictation

6  $d \frac{5}{17} b$

- 1 I think he'll bring the keys.
- 2 Will they throw out the microwave?
- 3 If you learn to code, you'll get a good job.
- 4 Roy will be happy if you buy him this video game.
- 5 If you travel to that area, you won't have Wi-Fi.

## Grammar – page 95

- 7 1 will buy 3 Will ... damage  
2 won't be 4 won't turn off
- 8 1 We will speak to all our electrical devices in the future.  
2 Will power from the sun give us all our electricity in 2050?  
3 All video games will use virtual reality technology in five years.  
4 Will all school students learn how to code in ten years?  
5 Shops won't sell 3G mobile phones next year.
- 9 1 won't buy 4 will give  
2 doesn't have 5 learns  
3 will lose
- 10 1 clean up, will cook  
2 will use, isn't  
3 don't turn on, won't find  
4 will lend, doesn't work  
5 doesn't throw out, will reuse
- 11 1 slower than 6 many  
2 her 7 must  
3 There weren't 8 is buying  
4 doesn't have 9 is going  
5 was repairing 10 Did Simon water

## Translation

- 12 1 Will she record this song?  
2 When will you return my hairdryer?  
3 If he doesn't repair the washing machine, we'll buy a new one.  
4 I think I will store the files on an external hard drive.  
5 If I receive the program, I will install it today.

## Standards Check – page 96

### Written Comprehension

- 1 1 F 2 T 3 F 4 T 5 F
- 2 1 charger 4 secret window  
2 recipes 5 Microwaves  
3 Sensors

### Written Production

- 3 Accept all logical and grammatically correct answers.

## Oral Comprehension – page 97

4  $d \frac{5}{18} b$

### Conversation 1:

- Ellie:** Hi Jenny, your hair smells really nice.  
**Jenny:** Thanks Ellie. My mum's a hairdresser, and she tried a new shampoo on me last night. It doesn't come in a plastic bottle.  
**Ellie:** How can you have shampoo without a bottle?  
**Jenny:** Easily. This shampoo looks like soap – you know the old-fashioned kind. It's solid, not liquid.  
**Ellie:** Interesting! Send me a picture!  
**Jenny:** Sure, I think everyone will use it soon. People today are worried about the environment.  
**Ellie:** Maybe I'll try it, too. How else are your family saving the planet?  
**Jenny:** Last week we bought toothbrushes from natural materials. I'm not sure how good they are, but I promise to tell you after my next visit to the dentist!

### Conversation 2:

- Mark:** I want to stream a film. Can you turn off your speakers, please, Stacey?  
**Stacey:** Mark, if you watch a film on the Internet, it will make my video game slow. Our Wi-Fi is terrible.  
**Mark:** If you ask Dad, maybe he'll agree to get more bandwidth.  
**Stacey:** Or, we can wait for Li-Fi.  
**Mark:** What's Li-Fi?  
**Stacey:** It's an Internet connection like Wi-Fi, but more than 100 times faster.  
**Mark:** How?  
**Stacey:** Well, instead of radio-waves, Li-Fi transfers data through LED lamps. So if we install them in our house, we'll have Li-Fi connection. From what I read, everyone will have it in their homes in about three to four years.  
**Mark:** I don't think I can wait that long for fast Internet!

- 1 hair 4 turn off  
2 soap 5 100  
3 natural 6 LED lamps

## Oral Production

- 5 1 a 2 b 3 a 4 a 5 b

## GRAMMAR APPENDIX

### INTRODUCTION page 112

- 1** 1 Her      3 Their      5 your  
2 My      4 Its      6 Our
- 2** 1 Hannah's necklace is beautiful.  
2 The dog's name is Max.  
3 The students' project is excellent.  
4 Lewis' / Lewis's sunglasses are in the kitchen.  
5 The children's sandwiches are on the table.

### page 113

- 3** 1 is      5 Is  
2 Are      6 aren't / are not  
3 'm not / am not      7 Is  
4 are      8 is
- 4** 1 Has Heidi got green eyes?  
2 I have got a new handbag.  
3 We haven't got eggs.  
4 Have you got a computer in your room?  
5 Our flat has got a small kitchen.  
6 Elliot hasn't got a coat.
- 5** 1 Is, has got      3 Have ... got, have got  
2 are, 'm / am      4 isn't, haven't got
- 6** 1 There is      4 there isn't  
2 Is there      5 Are there  
3 There are      6 there aren't

### # UNIT 1 page 114

- 1** 1 a      3 an      5 many      7 much  
2 the      4 some      6 any
- 2** 1 an      3 Many      5 The      7 some  
2 a      4 any      6 much
- 3** 1 How many      4 How many  
2 How much      5 How much  
3 How many      6 How much
- Accept all logical and grammatically correct answers.

### page 115

- 1** 1 paints      4 explore  
2 live      5 doesn't usually order  
3 don't go
- 2** 1 go      4 watch  
2 exercises      5 doesn't ... go out  
3 don't work      6 studies

- 3** 1 Do Kelly and Paul go abroad every summer?  
2 What does Sam usually do on holiday?  
3 Does Mark enjoy playing football?  
4 When does the tour begin?  
5 Who do you often see on Sundays?

- 4** 1 c    2 d    3 a    4 e    5 b  
a doesn't like      d takes  
b meet      e starts  
c don't ... travel

### # UNIT 2 page 116

- 1** 1 am saving, flash drive  
2 aren't playing, computer games  
3 are looking, microscope  
4 am not taking, compass  
5 isn't having, lunch
- 2** 1 is writing      4 'm / am looking  
2 are putting      5 'm / am not talking  
3 isn't working
- 3** 1 Are you exploring the city now?  
2 What is your friend doing right now?  
3 Are your parents working at the moment?  
4 Is your teacher using the projector right now?  
5 Who is speaking at the moment?  
1 c    2 e    3 b    4 d    5 a

### page 117

- 1** 1 is driving      4 walk  
2 takes      5 aren't riding  
3 doesn't go      6 am talking
- 2** 1 is visiting      4 travel  
2 sails      5 'm / am not meeting  
3 aren't playing      6 doesn't ... run
- 3** 1 How do you usually get to school?  
2 Is your mum driving to work today?  
3 Are you and your friend chatting right now?  
4 Does your English teacher always give homework?  
5 What app do you often use?  
6 What are you having for lunch today?
- Accept all logical and grammatically correct answers.
- 4** 1 My friends aren't going out right now.  
2 Nick often shops at the market.  
3 Does your mum cook every day?  
4 I am taking the tram to school now.  
5 Josh isn't exercising at the moment.

## # UNIT 3 page 118

- 1** 1 There weren't                      4 There wasn't  
2 There were                            5 There wasn't  
3 There was
- 2** 1 There weren't                      4 There were  
2 There was                              5 There wasn't  
3 There was
- 3** 1 Was there                              4 Was there  
2 Were there                            5 Were there  
3 Was there
- Accept all logical and grammatically correct answers.

### 4 Possible answers

- 1 There was a snake in the park on Monday.
- 2 There weren't any good films on TV last night.
- 3 Were there many people in the town square last week?
- 4 There was a terrible hurricane in Florida several years ago.
- 5 There weren't any ships in the port two weeks ago.
- 6 Was there any beef for dinner yesterday?

## page 119

- 1** 1 painted      3 started      5 cleaned  
2 went          4 cried          6 ran
- 2** 1 played      3 flew      5 wrote  
2 bought      4 took      6 drove
- 3** 1 Paul walked to school yesterday. / Yesterday, Paul walked to school.  
2 The new restaurant opened last week. / Last week, the new restaurant opened.  
3 The film began five minutes ago. / Five minutes ago, the film began.  
4 I drank three cups of coffee this morning. / This morning, I drank three cups of coffee.  
5 Jessica and her grandfather had dinner together last night. / Last night, Jessica and her grandfather had dinner together.  
6 We watched a very good film last night. / Last night, we watched a very good film.

## # UNIT 4 page 120

- 1** 1 I didn't leave my umbrella here yesterday.  
2 Gary didn't break his arm.  
3 They didn't sail on the River Thames.  
4 I didn't buy a tablet.  
5 We didn't take the tram.  
6 Leslie's grandparents didn't hike in the mountains.
- 2** 1 didn't call                      4 didn't have  
2 made                              5 drove  
3 didn't walk                      6 tidied

- 3** 1 The cleaner didn't clean the windows yesterday.  
2 The tour guide took the tourists to the church in the morning.  
3 The ambulance got there after 10 minutes.  
4 The climbers didn't take a first-aid kit yesterday.  
5 We waited in a safe place.  
6 The singer didn't sing my favourite song.

### 4 Possible answers

- 1 I broke my arm two months ago.
- 2 Our maths teacher didn't give homework yesterday.
- 3 My friend visited us last weekend.
- 4 My grandparents didn't go abroad this year.
- 5 My family had dinner together yesterday.
- 6 I had an accident last summer.

## page 121

- 1** 1 Did they stand up when the president came in?  
2 Did you find your way easily?  
3 When did your niece arrive?  
4 Did he forget your birthday?  
5 Where did she get lost?  
6 What did they buy?

1 c   2 f   3 a   4 e   5 d   6 b

- 2** 1 When did you fly to Ethiopia?  
2 Why did you go to Ethiopia?  
3 Where did you stay?  
4 Did you work with other students?  
5 Did you work hard? / Did you have a good time?

- 3** 1 didn't compete                      4 Did ... carry  
2 Did ... win                              5 did ... talk  
3 rescued                                  6 didn't hurt
- 4** 1 did ... do                              4 did ... arrive  
2 Did ... use                              5 Did ... take  
3 Did ... go                                6 did ... have

Accept all logical and grammatically correct answers.

## # UNIT 5 page 122

- 1** 1 were hiking                              4 was climbing  
2 was watching                            5 was sitting  
3 were lying                                6 were cleaning
- 2** 1 c   2 a   3 d   4 b   5 e  
1 was looking                              4 was cutting  
2 were walking                              5 was holding  
3 were falling

**3 Possible answers**

- 1 I was making a video.
- 2 The students were writing messages.
- 3 My sister was surfing the web.
- 4 My parents were listening to music.
- 5 My friend was playing computer games.
- 6 The cat was sleeping under the sofa.

- 4**
- |                |               |
|----------------|---------------|
| 1 was shining  | 4 were eating |
| 2 were having  | 5 was telling |
| 3 were sitting |               |

**page 123**

- 1**
- |                     |                  |
|---------------------|------------------|
| 1 weren't enjoying  | 4 weren't taking |
| 2 wasn't crying     | 5 wasn't hiking  |
| 3 weren't listening | 6 wasn't holding |

- 2**
- 1 My friends were laughing at my funny stories.
  - 2 Les wasn't riding his motorbike at midnight.
  - 3 The athletes weren't training for the competition yesterday morning.
  - 4 I was climbing up the hill at 6.00 am.
  - 5 The author was talking about her new book.
  - 6 You weren't waiting at the corner at 4.00.

- 3**
- 1 Were they working in the field at 5.00 am?
  - 2 Were you sitting on the grass?
  - 3 Where were you hiking?
  - 4 Why was Jennifer crying?
  - 5 Was Mum holding her handbag?
  - 6 Who was Mr Evans talking to?

1 d 2 f 3 a 4 e 5 b 6 c

- 4**
- |                    |                   |
|--------------------|-------------------|
| 1 weren't laughing | 4 Were ... riding |
| 2 was ... wearing  | 5 wasn't using    |
| 3 was lying        | 6 were hiking     |

**# UNIT 6 page 124**

- 1** Accept all logical and grammatically correct answers.

- 2**
- 1 Can monkeys fly? No, they can't.
  - 2 Can an elephant jump? No, it can't.
  - 3 Can dogs swim? Yes, they can.
  - 4 Can a snake kill a mouse? Yes, it can.

- 3**
- |            |            |
|------------|------------|
| 1 couldn't | 4 could    |
| 2 could    | 5 couldn't |
| 3 couldn't |            |

- 4**
- 1 Could people drive cars in the 15th century?  
No, they couldn't.
  - 2 Could your grandparents watch TV when they were 20 years old?  
Yes, they could.
  - 3 Could you use a mobile phone when you were four years old?  
No, I couldn't.
  - 4 Could people see films in the cinema in 1960?  
Yes, they could.

**page 125**

- 1**
- |           |           |
|-----------|-----------|
| 1 mustn't | 4 mustn't |
| 2 must    | 5 mustn't |
| 3 must    | 6 must    |

- 2**
- 1 Should I wear this dress to the party?
  - 2 You shouldn't leave school before age 18.
  - 3 They should take a first-aid kit.
  - 4 He should try to get a job.
  - 5 How should we solve this problem?
  - 6 You shouldn't swim here.

- 3**
- |            |           |
|------------|-----------|
| 1 must     | 5 Should  |
| 2 couldn't | 6 mustn't |
| 3 should   | 7 can     |
| 4 can't    | 8 Could   |

**# UNIT 7 page 126**

- 1**
- |                         |                       |
|-------------------------|-----------------------|
| 1 colder than           | 4 wider than          |
| 2 calmer than           | 5 more difficult than |
| 3 more interesting than | 6 funnier than        |

- 2**
- |                      |                       |
|----------------------|-----------------------|
| 1 darker than        | 4 bigger than         |
| 2 more athletic than | 5 more creative than  |
| 3 safer than         | 6 more confident than |

- 3**
- 1 Carrie is more careful than Ron.
  - 2 The yellow curtains are longer than the white curtains.
  - 3 My friend is more clever than me.
  - 4 I am quieter than you.
  - 5 Dolphins are more intelligent than turtles.
  - 6 Mrs Parker is kinder than Ms Burke.

- 4**
- 1 Summer is hotter than winter.
  - 2 A butterfly is more beautiful than a spider.
  - 3 Football / Basketball is more interesting / exciting than basketball / football.
  - 4 Science-fiction / Crime films are more exciting / interesting than crime / science-fiction films.

**page 127**

- 1**
- |          |        |
|----------|--------|
| 1 theirs | 4 his  |
| 2 yours  | 5 ours |
| 3 hers   | 6 mine |

- 2** 1 mine                      4 his  
 2 yours                      5 ours  
 3 hers
- 3** 1 his                      4 ours  
 2 mine                      5 hers  
 3 theirs
- 4** 1 hers                      4 his  
 2 mine                      5 theirs  
 3 ours

## # UNIT 8 page 128

- 1** 1 am going to repair  
 2 is going to sell  
 3 aren't going to keep  
 4 are going to borrow  
 5 am not going to buy
- 2** 1 Are ... going to celebrate  
 2 is ... going to arrive  
 3 Is ... going to compete  
 4 Are ... going to drive  
 5 are ... going to see  
 6 is ... going to order  
 1 d 2 e 3 b 4 f 5 c 6 a
- 3** 1 are going to have  
 2 am going to buy  
 3 aren't going to take  
 4 isn't going to ride  
 5 Is ... going to investigate

### 4 Possible answers

- 1 I'm going to volunteer at the animal shelter today.  
 2 The teacher is going to return our tests tomorrow.  
 3 Dean and I aren't going to hike in the canyon on Saturday morning.  
 4 The boys aren't going to join a group this afternoon.  
 5 Is Mum going to drive to the shopping centre this week?  
 6 Are you going to explore the city next month?

## page 129

- 1** 1 am meeting                      4 is arriving  
 2 aren't playing                      5 aren't going  
 3 is leaving                      6 am not taking
- 2** 1 What are you and your friends doing this weekend?  
 2 Is your best friend coming to your house today?  
 3 Are you and your family going abroad next summer?  
 4 Is your maths teacher giving your class a test next week?  
 5 What are you having for dinner tonight?  
 Accept all logical and grammatically correct answers.

- 3** 1 c 2 a 3 e 4 b 5 d  
 1 are ... going                      4 are ... volunteering  
 2 are ... cooking                      5 Is ... working  
 3 Is ... flying  
 a am making                      d is giving  
 b are participating                      e is travelling  
 c is taking

## # UNIT 9 page 130

- 1** 1 will damage                      4 will have  
 2 won't be                      5 will agree  
 3 will lend                      6 won't make
- 2** 1 Will people live on other planets in the next century?  
 2 Will there be more crime in the future?  
 3 Will Julia finish the race?  
 4 What will happen to these animals?  
 5 When will the temperature go down?  
 1 c 2 e 3 b 4 a 5 d
- 3** 1 will ... be                      4 won't endanger  
 2 will enjoy                      5 will return  
 3 won't get
- 4 Possible answers**  
 1 I will win the race.  
 2 The detectives will solve the crime.  
 3 The students won't pass the test.  
 4 The lion won't kill the antelope.  
 5 Will you find the way?  
 6 Will the firefighter rescue the child?

## page 131

- 1** 1 will send                      4 will transfer  
 2 buy                      5 won't be  
 3 don't turn on                      6 you are
- 2** 1 gets                      4 will be  
 2 will phone                      5 will feel  
 3 rains                      6 doesn't graduate
- 3** 1 d 2 c 3 f 4 a 5 b 6 e  
 1 won't make                      4 doesn't save  
 2 will watch                      5 arrives  
 3 don't use                      6 will be
- 4** 1 study, will pass                      4 doesn't repair, will take  
 2 will feel, takes                      5 will fall, aren't  
 3 is, will go

## INTRODUCTION page 147

### 1 THE HOME

bathroom – (cuarto de) baño  
bedroom – dormitorio, habitación, cuarto  
chair – silla  
cooker – cocina (fogones y horno)  
cupboard – armario  
curtain – cortina  
desk – escritorio  
dining room – comedor  
fridge – nevera, frigorífico  
kitchen – cocina  
living room – cuarto de estar, salón  
rug – alfombra  
shower – ducha  
sink – fregadero, pila; lavabo  
sofa – sofá  
table – mesa  
toilet – baño, aseo, servicio; váter

### FOOD AND TABLEWARE

apple – manzana  
beef – (carne de) ternera / vaca  
bowl – tazón, cuenco, bol  
bread – pan  
cake – tarta, pastel  
cereal – cereal/es  
cheese – queso  
chicken – pollo  
chips – patatas fritas  
cup – taza  
egg – huevo  
fizzy drink – bebida / refresco con gas  
fork – tenedor  
glass – vaso  
ham – jamón  
ice cream – helado  
juice – zumo  
knife – cuchillo  
lamb – (carne de) cordero  
onion – cebolla  
orange – naranja  
plate – plato  
potato – patata  
serviette – servilleta  
soup – sopa  
spoon – cuchara  
steak – filete, bistec  
toast – tostada/s  
tomato – tomate

### CLOTHES AND ACCESSORIES

bracelet – pulsera, brazaletes  
coat – abrigo  
dress – vestido  
earrings – pendientes  
glasses – gafas  
gloves – guantes  
handbag – bolso (de mano)  
hat – sombrero  
jacket – chaqueta  
jeans – (pantalones) vaqueros  
jewellery – joyas  
make-up – maquillaje  
necklace – collar  
ring – anillo  
sandals – sandalias  
shirt – camisa  
shoes – zapatos  
shorts – pantalones cortos, *shorts*  
socks – calcetines  
suit – traje  
sunglasses – gafas de sol  
sweater – jersey, suéter  
trainers – zapatillas de deporte  
trousers – pantalones  
T-shirt – camiseta  
umbrella – paraguas

### WEATHER

cloud – nube  
cold – frío/a (*it's ~: hace frío*)  
cool – fresco/a (*it's ~: hace fresco*)  
dry – seco/a, árido/a  
fog – niebla  
hot – caluroso/a, cálido/a (*it's ~: hace calor*)  
ice – hielo  
lightning – rayo/s; relámpago/s  
rain – lluvia  
snow – nieve  
storm – tormenta  
sun – sol  
temperature – temperatura  
thunder – trueno/s  
warm – cálido/a, templado/a (*it's ~: hace calor*)  
wet – lluvioso/a  
wind – viento

## PLACES AROUND TOWN

bakery – panadería; pastelería  
bookshop – librería  
café – cafetería, café  
church – iglesia  
cinema – cine  
department store – grandes almacenes  
hospital – hospital  
hotel – hotel  
library – biblioteca  
museum – museo  
park – parque  
port – puerto  
shopping centre – centro comercial  
sports centre – polideportivo  
supermarket – supermercado  
train station – estación de tren

2

l	h	c	u	r	t	a	i	n	v	k	w
c	i	o	f	c	o	o	k	e	r	d	p
h	o	g	s	r	c	h	e	e	s	e	v
i	r	w	h	p	i	m	u	s	e	u	m
c	a	b	i	t	i	d	d	e	s	k	p
k	n	p	e	n	n	t	g	f	o	g	l
e	g	b	o	e	d	i	a	e	p	n	w
n	e	t	e	r	f	q	n	l	o	t	e
c	h	u	r	c	h	l	y	g	r	b	t
z	a	b	c	p	o	m	n	r	t	o	y

1 curtain, cooker, desk, fridge

2 chicken, orange, beef, cheese

3 fog, wet, lightning, wind

4 hospital, museum, church, port

3 1 knife

4 bowl

2 kitchen

5 hotel

3 bathroom

6 thunder

4 bracelet, coat, dress, earrings, glasses, handbag, hat, jacket, jeans, necklace, ring, sandals, shirt, shoes, shorts, socks, sunglasses, trainers, trousers, T-shirt

## # UNIT 1 page 149

### 1 AROUND TOWN

amusement park – parque de atracciones  
bank – banco  
bridge – puente  
bus stop – parada de autobús  
car park – aparcamiento de coches, *parking*  
corner – esquina  
factory – fábrica  
market – mercado, mercadillo

playground – zona de juegos, parque infantil  
post office – oficina de correos  
roundabout – rotonda, glorieta  
sight – lugar de interés turístico; espectáculo  
stop sign – (señal de) *stop*  
town square – plaza (del pueblo / de la ciudad)  
traffic light – semáforo  
zebra crossing – paso de cebra / peatones

### ACTIVITIES

exercise – hacer ejercicio  
explore – explorar  
go abroad – ir(se) al extranjero  
go bowling – ir a jugar a los bolos  
go camping – ir(se) de *camping* / acampada  
go ice skating – ir a patinar sobre hielo  
go out – salir  
go sightseeing – hacer turismo  
hike – hacer senderismo, dar una caminata  
join a group – unirse a un grupo  
order pizza – pedir pizza  
paint – pintar  
see a show – ver un espectáculo / programa  
take a trip – hacer un viaje  
take tours – hacer visitas / excursiones

### GIVING INFORMATION

Where can I get ... ? – ¿Dónde puedo conseguir / comprar...?

Try ... . There are some ... there. – Prueba... . Hay algunos/as... allí.

Which do you recommend? – ¿Cuál me recomiendas?

Is it hard to find? – ¿Cuesta / Es difícil encontrarlo/a?

No, not at all, it's ... . You can't miss it. – No, para nada, está... . No tiene pérdida.

### TALKING ABOUT TRIPS

How often do you take trips? – ¿Con qué frecuencia haces viajes?

Where do you usually go? – ¿Adónde sueles ir / vas normalmente?

What do you do on your trips? – ¿Qué haces en los viajes?

Who do you go with? – ¿Con quién vas?

Where do you stay? – ¿Dónde os alojáis?

2 Path follows these words: market-playground-bank-post office-bridge-town square-car park-roundabout-bus stop

capital city: Oslo

3 1 go ice skating

6 join a group

2 go bowling

7 order pizza

3 go abroad

8 take a trip

4 go camping

9 take tours

5 go sightseeing

10 see a show

4 Tick: 1, 3, 5, 6

## # UNIT 2 page 151

### 1 SCHOOL ITEMS

atlas – atlas  
calculator – calculadora  
compass – compás  
dictionary – diccionario  
flash drive – memoria USB  
glue – pegamento, cola  
laptop – ordenador portátil  
map – mapa; plano  
microscope – microscopio  
paintbrush – pincel  
paints – pinturas  
projector – proyector  
scissors – tijeras  
stapler – grapadora  
tablet – tableta  
textbook – libro de texto  
whiteboard – pizarra blanca

### TRANSPORT

aeroplane – avión  
boat – barco; barca  
drive – conducir; llevar / ir en coche  
electric bike – bici eléctrica  
ferry – transbordador, ferri  
helicopter – helicóptero  
lorry – camión  
minivan – monovolumen, miniván  
motorbike – moto  
ride – montar / ir (en / a)  
sail – navegar; gobernar (un barco)  
scooter – escúter, vespa  
ship – barco  
take – coger (transporte); llevar (a)  
taxi – taxi  
train – tren  
tram – tranvía  
underground – metro

### CHOOSING SCHOOL ITEMS

What are you doing? – ¿Qué estás haciendo?  
What are you looking for? – ¿Qué estás buscando?  
How much is it? – ¿Cuánto es / cuesta?  
Why don't you get that? – ¿Por qué no compras ese/a?  
How about this one? – ¿Qué te parece este/a?  
What's the item number? – ¿Cuál es el número del artículo?  
What else do you need? – ¿Qué más necesitas?

### TALKING ABOUT A PHOTO

Who's in the photo? – ¿Quién sale en la foto?  
What are they doing? – ¿Qué están haciendo?  
Where are they? – ¿Dónde están?  
Do they look happy? – ¿Parecen felices?  
What else can you see? – ¿Qué más ves / puedes ver?

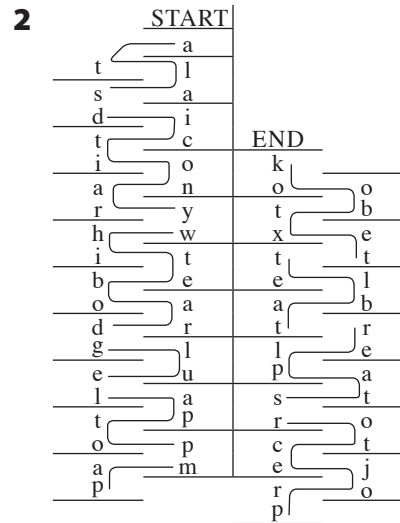

atlas, dictionary, whiteboard, glue, laptop, map,  
projector, stapler, tablet, textbook

3 Code: b = 4 e = 8 i = 12 m = 16 n = 18 p = 22  
r = 24 s = 26 u = 30

1 scissors, paintbrush, paints

2 calculator, compass

3 microscope

Emily – art

Oliver – maths

Dan – science

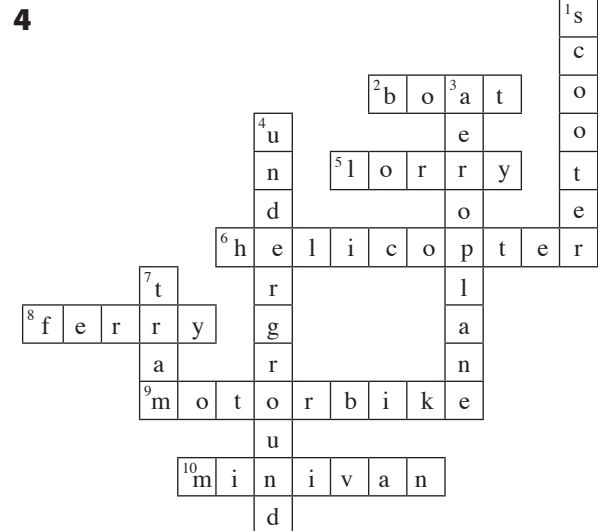

## # UNIT 3 page 153

### 1 FAMILY

daughter – hija  
granddaughter – nieta  
grandparent – abuelo/a  
grandson – nieto  
husband – marido, esposo  
nephew – sobrino  
niece – sobrina  
parent – padre / madre

son – hijo  
stepdaughter – hijastra  
stepfather – padrastro  
stepmother – madrastra  
stepson – hijastro  
wife – mujer, esposa

## JOBS

actor – actor / actriz  
artist – artista  
astronaut – astronauta  
author – autor/a  
businessperson – empresario/a, persona de negocios  
cleaner – limpiador/a  
dentist – dentista  
driver – conductor/a  
firefighter – bombero/a  
hairdresser – peluquero/a  
mechanic – mecánico/a  
musician – músico/a  
nurse – enfermero/a  
pilot – piloto  
salesperson – dependiente/a, vendedor/a  
singer – cantante  
tour guide – guía turístico/a  
waiter – camarero (camarera = *waitress*)

## TALKING ABOUT A TV PROGRAMME

Was there anything good on TV last night? –  
¿Dieron / Echaron algo bueno en la tele anoche?  
Was it a ... ? – ¿Era un/a...?  
What was it about? – ¿De qué iba / trataba?  
Were there any famous actors in it? – ¿Salía algún actor /  
alguna actriz famoso/a?  
What was your favourite scene? – ¿Cuál fue tu escena  
preferida?

## GETTING INFORMATION

What do you know about the community centre? – ¿Qué  
sabes sobre el centro social?  
What do you do there? – ¿Qué haces / se hace allí?  
... isn't for me. What else is there? – ... no es para mí.  
¿Qué más hay?  
Maybe you'd like that? – ¿A lo mejor te gustaría eso?  
I don't really like ... . I think I'd prefer a class. Any  
suggestions? – No me gusta/n mucho... . Creo que  
preferiría una clase. ¿Alguna sugerencia?  
How about a ... class? – ¿Qué tal / te parece una clase  
de...?  
I hear ... . – He oído / Tengo entendido que... .  
That's not a bad idea! I'd like to try something new. –  
¿Esa no es una mala idea! Me gustaría probar algo  
nuevo.  
When is the class? – ¿Cuándo es la clase?  
I think it's on ... . – Creo que es los...

2 parents grandson  
wife niece  
nephew grandparents  
husband

The hidden word is: The Simpsons

3 Is there a **perfect** job?

4 1 Cleaners 10-8 = 2      4 Mechanics 6-3 = 3  
2 Actors 7-2 = 5      5 Singers 5-1 = 4  
3 Drivers 8-4 = 4      6 Nurses 9-7 = 2  
Total: 20

## # UNIT 4 page 155

### 1 EMERGENCIES

accident – accidente  
ambulance – ambulancia  
break a leg – romperse una pierna  
call for help – pedir auxilio / ayuda  
dangerous – peligroso/a  
fall – caer(se)  
first-aid kit – botiquín de primeros auxilios  
hurt – hacer(se) daño  
injure – herir, lesionar  
kill – matar (a)  
prevent – evitar, prevenir  
safe – seguro/a (*stay ~*: mantenerse a salvo)  
slip – resbalar(se)

### VERBS

arrive – llegar  
carry – llevar (encima); transportar  
compete – competir, participar  
find your way – encontrar el camino, orientarse  
forget – olvidar(se)  
get lost – perderse  
give up – darse por vencido/a; abandonar  
hold – sujetar; coger  
lie down – tumbarse  
lose – perder  
rescue – rescatar, salvar  
stand up – estar / mantenerse de pie  
train – entrenar, prepararse  
win – ganar

### TALKING ABOUT THE PAST

Here's something you probably didn't know. – Esto es  
algo que probablemente no supieras.  
I believe you. – Te creo.  
That's right. – Así es., Exacto.  
Well, here's something else. – Bien, otra cosa más.  
I can't believe that. – Eso no me lo creo / puedo creer.  
Really? What happened? – ¿De verdad? ¿Qué pasó?



## # UNIT 6 page 159

### 1 LIFE EVENTS

be born – nacer  
 celebrate – celebrar  
 die – morir  
 fall in love – enamorarse  
 get a job – conseguir un trabajo  
 get divorced – divorciarse  
 get married – casarse  
 graduate – graduarse  
 grow up – hacerse mayor  
 have a baby – tener un bebé  
 leave school – dejar los estudios; terminar el colegio  
 move in – instalarse, mudarse  
 separate – separarse

### CRIME

arrest – arrestar (a)  
 catch – coger / atrapar (a)  
 criminal – criminal; delincuente  
 detective – detective  
 evidence – prueba/s  
 examine – examinar  
 fingerprint – huella dactilar / digital  
 footprint – huella  
 investigate – investigar  
 murder – asesinar / matar a  
 police officer – (agente de) policía  
 prison – cárcel, prisión  
 robbery – robo  
 security guard – guarda jurado/a, guardia de seguridad  
 solve – resolver  
 steal – robar, hurtar  
 weapon – arma

### COMPARING ABILITIES

Can you ... well? – ¿Sabes / Puedes... bien?  
 Yes, I can. – Sí.  
 No, I can't. – No.  
 Could you ... well five years ago? – ¿Sabías / Podías...  
 bien hace cinco años?  
 Yes, I could. – Sí.  
 No, I couldn't. – No.

### TALKING ABOUT A BOOK

Can you recommend a book for me? – ¿Me recomiendas /  
 puedes recomendar un libro?  
 What kind of books do you like? – ¿Qué tipo de libros te  
 gustan?  
 I usually read ... . – Normalmente leo... .  
 You should read ... . – Deberías leer... .  
 What's it about? – ¿Sobre qué trata?, ¿De qué va?  
 It's about ... . – Trata sobre... ., Va de... .  
 Who are the main characters? – ¿Quiénes son los/as  
 protagonistas?  
 The main characters are ... . – Los/as protagonistas son...

- |   |                |                |
|---|----------------|----------------|
| 2 | 1 be born      | 6 graduate     |
|   | 2 fall in love | 7 grow up      |
|   | 3 get a job    | 8 have a baby  |
|   | 4 get divorced | 9 leave school |
|   | 5 get married  | 10 move in     |

3	fell in love Ben	moved in Ben	had a baby Ben
	graduated Ben	got divorced Kim	celebrated Kim
	died Kim	got a job Ben	grew up Kim

Ben is the winner.

### 4

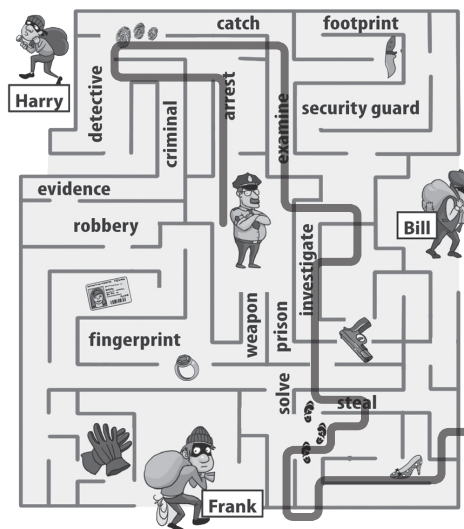

The thief was Bill. The clues were fingerprints, a gun and footprints.

- |   |               |             |
|---|---------------|-------------|
| 5 | 1 murder      | 4 evidence  |
|   | 2 prison      | 5 robbery   |
|   | 3 investigate | 6 detective |

## # UNIT 7 page 161

### 1 ADJECTIVES 1

boring – aburrido/a  
 frightening – aterrador/a, espantoso/a  
 horrible – horrible  
 huge – enorme, gigantesco/a  
 interesting – interesante  
 modern – moderno/a; actual  
 narrow – estrecho/a  
 normal – normal, habitual  
 old-fashioned – anticuado/a, pasado/a de moda  
 pretty – bonito/a; guapa  
 thick – grueso/a; tupido/a  
 thin – fino/a; delgado/a  
 tiny – minúsculo/a, diminuto/a  
 trendy – moderno/a, de moda  
 unique – único/a, excepcional  
 wide – ancho/a  
 wonderful – maravilloso/a

### ADJECTIVES 2

afraid – asustado/a (*be ~ to / of*: tener miedo de)  
 angry – enfadado/a (*get ~*: enfadarse)  
 calm – tranquilo/a  
 careful – prudente, cuidadoso/a (*be ~*: tener cuidado)  
 difficult – difícil, complicado/a  
 famous – famoso/a  
 hungry – hambriento/a (*be ~*: tener hambre)  
 lucky – afortunado/a (*be ~*: tener suerte)  
 nervous – nervioso/a  
 noisy – ruidoso/a  
 polite – educado/a  
 quick – rápido/a, veloz  
 quiet – tranquilo/a; silencioso/a; callado/a  
 rude – maleducado/a (*it's ~*: es de mala educación)  
 simple – fácil, sencillo/a  
 slow – lento/a  
 thirsty – sediento/a (*be ~*: tener sed)  
 worried – preocupado/a

### COMPARING PEOPLE

She isn't ... and she isn't ... . – Ella no es... y no es... .  
 She is ... than ..., but she is ... than ... . – Ella es...  
 que... , pero es... que... .  
 Her hair is ... than ... . – Su pelo es... que... .  
 Her clothes are ... than ... . – Su ropa es... que... .  
 She is ... than all the other celebrities in the photos. –  
 Ella es... que todas las otras famosas de las fotos.

## DOING A SURVEY

What makes you nervous? – ¿Qué te pone nervioso/a?  
 How often do you get angry? – ¿Con qué frecuencia te enfadas?  
 Do you enjoy noisy parties? – ¿Disfrutas de / Te gustan las fiestas ruidosas?  
 What helps you to feel calm? – ¿Qué te ayuda / sirve para estar tranquilo/a?  
 What do you do when people are rude to you? – ¿Qué haces cuando la gente es maleducada contigo?

2

i	n	j	w	b	g	n	r	j	l	z	r	d
j	n	z	n	m	y	y	y	u	z	d	b	j
m	w	t	b	t	d	m	l	b	d	p	l	r
z	y	o	e	d	p	o	l	i	t	e	y	m
h	r	d	n	r	i	q	u	i	e	t	b	j
r	o	b	d	d	e	f	s	i	m	p	l	e
n	j	r	b	w	e	s	f	t	i	n	y	r
t	o	b	r	o	p	r	t	i	t	h	i	n
h	q	i	z	i	r	y	f	i	c	q	t	k
i	u	s	s	k	b	i	d	u	n	u	x	j
c	i	l	d	y	t	l	n	k	l	g	l	x
k	c	o	k	d	n	x	e	g	w	m	v	t
m	k	w	n	p	t	j	w	h	u	g	e	v

- |                 |                        |
|-----------------|------------------------|
| 1 thick – thin  | 5 boring – interesting |
| 2 polite – rude | 6 quick – slow         |
| 3 quiet – noisy | 7 wonderful – horrible |
| 4 tiny – huge   | 8 simple – difficult   |
- 
- |             |          |
|-------------|----------|
| 3 1 worried | 4 angry  |
| 2 thirsty   | 5 calm   |
| 3 nervous   | 6 afraid |
- 
- |            |               |
|------------|---------------|
| 4 1 hungry | 4 famous      |
| 2 trendy   | 5 frightening |
| 3 modern   | 6 narrow      |

## # UNIT 8 page 163

### 1 VERBS

agree – estar / ponerse de acuerdo  
 borrow – tomar / pedir prestado/a  
 bring – traer; llevar (~ *attention* to: hacer hincapié en)  
 collect – recoger; coleccionar; recaudar  
 disagree – no estar de acuerdo  
 donate – donar  
 finish – terminar, acabar  
 hear – oír; escuchar (~ *about*: enterarse / oír hablar de)  
 keep – conservar; mantener(se); quedarse con  
 lend – prestar, dejar  
 promise – prometer  
 repair – arreglar  
 return – devolver; volver  
 sell – vender  
 volunteer – trabajar como voluntario/a; ofrecerse voluntario/a

## THE ENVIRONMENT

clean up – limpiar  
damage – dañar, perjudicar, estropear  
endanger – poner en peligro  
pick up – recoger, coger  
plant – sembrar, plantar  
pollute – contaminar  
preserve – proteger, preservar; conservar  
recycle – reciclar  
reduce – reducir  
reuse – reutilizar, volver a usar  
throw out – tirar  
turn off – apagar  
turn on – encender  
waste – malgastar; desperdiciar

## ASKING FOR HELP

Would you mind ... ? – ¿Te importaría...?  
I'd be happy to help. What's the problem? – Estaría encantado/a de ayudar. ¿Cuál es el problema?  
Can you ... ? – ¿Puedes...?  
Certainly. – Por supuesto., Claro (que sí).  
Could you help me with ... ? – ¿Podrías ayudarme con...?  
Of course. How can I help? – Por supuesto. ¿Cómo / En qué puedo ayudar?  
I need some help ... . – Necesito (algo de) ayuda... .  
No problem. – Claro., No hay problema.  
Thanks. – Gracias.

## DESCRIBING A CITY

Are you having a good time? – ¿Te lo estás pasando bien?, ¿Te estás divirtiendo?  
What time is it there? – ¿Qué hora es allí?  
What's ... like? – ¿Cómo es...?  
It's a / an ... city. – Es una ciudad... .  
What else do you like about the city? – ¿Qué más te gusta de la ciudad?  
There are a lot of ... . – Hay muchos/as... .  
Like what? – ¿Como qué / cuáles?  
So how are you getting around? – ¿Y cómo te estás moviendo / desplazando?  
Mostly ... . – Principalmente... .

- |          |                    |                     |
|----------|--------------------|---------------------|
| <b>2</b> | <b>1</b> fields    | <b>4</b> a rock     |
|          | <b>2</b> a photo   | <b>5</b> nurses     |
|          | <b>3</b> a city    | <b>6</b> a sink     |
| <b>3</b> | <b>1</b> promise   | <b>7</b> agree      |
|          | <b>2</b> volunteer | <b>8</b> lend       |
|          | <b>3</b> Turn off  | <b>9</b> bring      |
|          | <b>4</b> sell      | <b>10</b> throw out |
|          | <b>5</b> return    | <b>11</b> borrow    |
|          | <b>6</b> keep      |                     |

The **blue** team wins.

- 4** Positive verbs: recycle, preserve, reuse, plant  
Negative verbs: endanger, pollute, waste, damage

## # UNIT 9 page 165

### 1 TECHNOLOGY

code – programar, codificar  
external hard drive – disco duro externo  
file – archivo; carpeta  
install – instalar  
keyboard – teclado  
memory card – tarjeta de memoria  
monitor – monitor  
mouse – ratón  
printer – impresora  
record – grabar  
screen – pantalla  
speakers – altavoces  
store – guardar, almacenar  
stream – transmitir (en directo)  
touchscreen – pantalla táctil  
transfer – pasar, transferir  
video game – videojuego  
Wi-Fi – wifi

### EVERYDAY ITEMS

air conditioner – aire acondicionado  
brush – cepillo  
charger – cargador  
hairdryer – secador de pelo  
houseplant – planta de interior  
kettle – hervidor (de agua)  
key – llave  
lamp – lámpara  
microwave – microondas  
pillow – almohada  
rubbish bin – cubo de la basura  
shampoo – champú  
soap – jabón  
toothbrush – cepillo de dientes  
toothpaste – pasta de dientes, dentífrico  
towel – toalla  
washing machine – lavadora

### ASKING FOR INFORMATION

Could you tell me more about it? – ¿Me podrías contar más sobre ello?  
What condition is it in? – ¿En qué condiciones está?  
Why are you selling it? – ¿Por qué lo vendes?  
How much do you want for it? – ¿Cuánto quieres por ello?  
Can I come and see it? – ¿Puedo ir a verlo?  
Is ... good for you? – ¿... te va / viene bien?

## DESCRIBING ITEMS

When do you use this item? – ¿Cuándo utilizas este artículo?

Where is it? – ¿Dónde está?

Does it use electricity? – ¿Usa / Consume electricidad?

What does it do? – ¿Qué hace?

### 2 1 mouse

a	c	o	u
e	m	r	s
t	b	e	n
m	f	g	o

### 4 monitor

b	i	k	g
m	n	t	y
o	f	m	o
a	c	r	d

### 2 keyboard

e	v	b	n
s	y	o	a
e	r	m	r
b	k	t	d

### 5 transfer

l	e	i	u
s	a	f	e
p	r	s	r
t	a	n	h

### 3 printer

t	n	t	o
s	i	e	r
o	r	r	e
m	q	s	p

### 6 code

m	e	w	h
o	q	e	v
f	d	u	i
a	t	b	y

### 3 1 air conditioner

2 screen

3 lamp

4 speaker

### 5 kettle

6 memory card

7 microwave

Let's play this video game.

### 4 Possible answers

- In picture A there is a hairdryer on the shelf, but there isn't a hairdryer in picture B.
- In picture B there is a brush on the shelf, but there isn't a brush in picture A.
- In picture A there are towels on the washing machine, but there aren't towels in picture B.
- In picture B there is a houseplant on the shelf, but there isn't a houseplant in picture A.
- In picture A there is toothpaste on the shelf, but there isn't toothpaste in picture B.
- In picture A there is one toothbrush on the shelf / in the cup, but in picture B there are two toothbrushes on the shelf / in the cup.
- In picture A there is soap on the sink, but there isn't soap on the sink in picture B.