

# CIRCUITOS ELÉCTRICOS AUTOMÓVIL

## 1. CIRCUITO DE ARRANQUE Y CARGA:

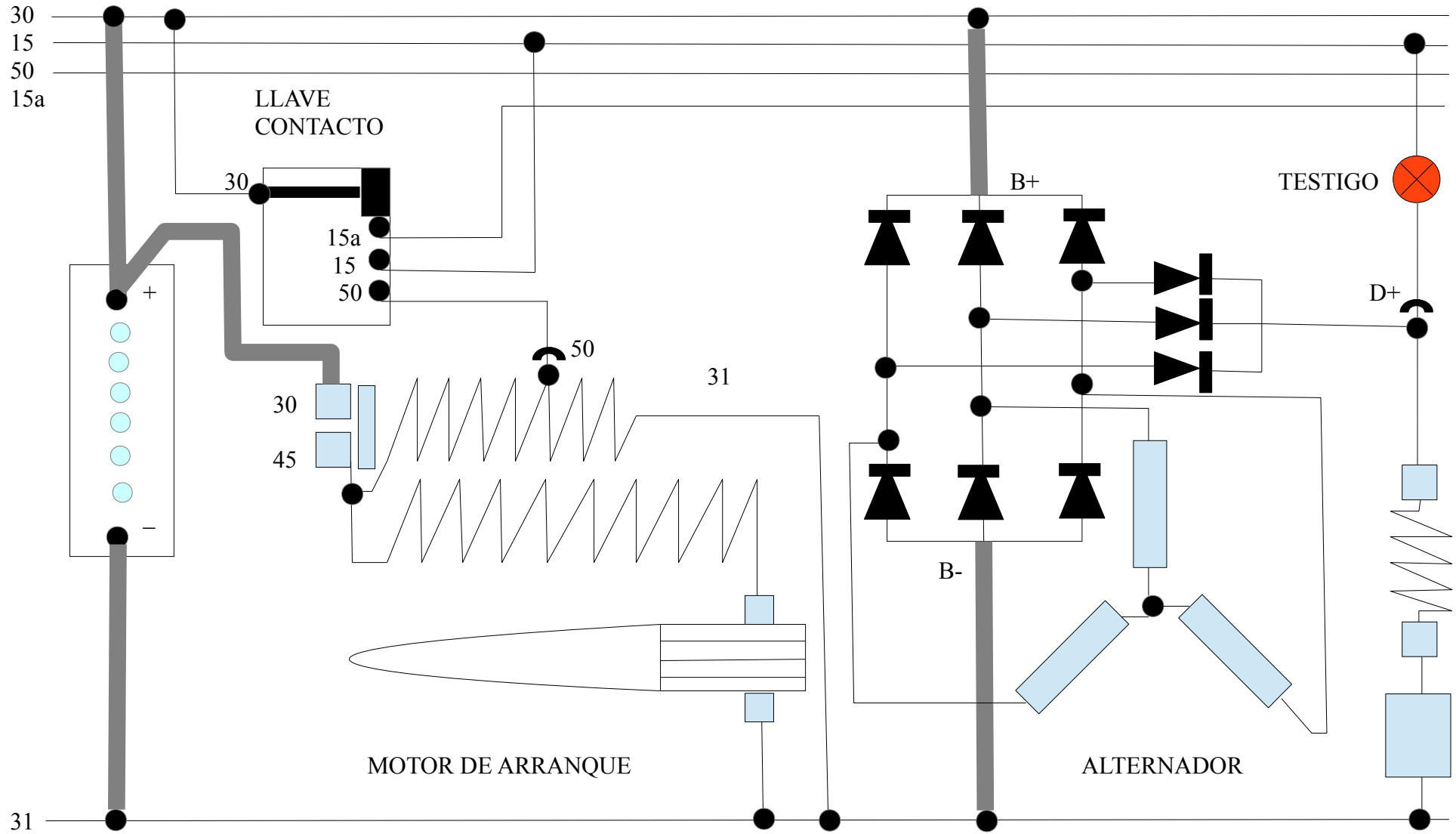

## 2. CIRCUITO DE ALUMBRADO:

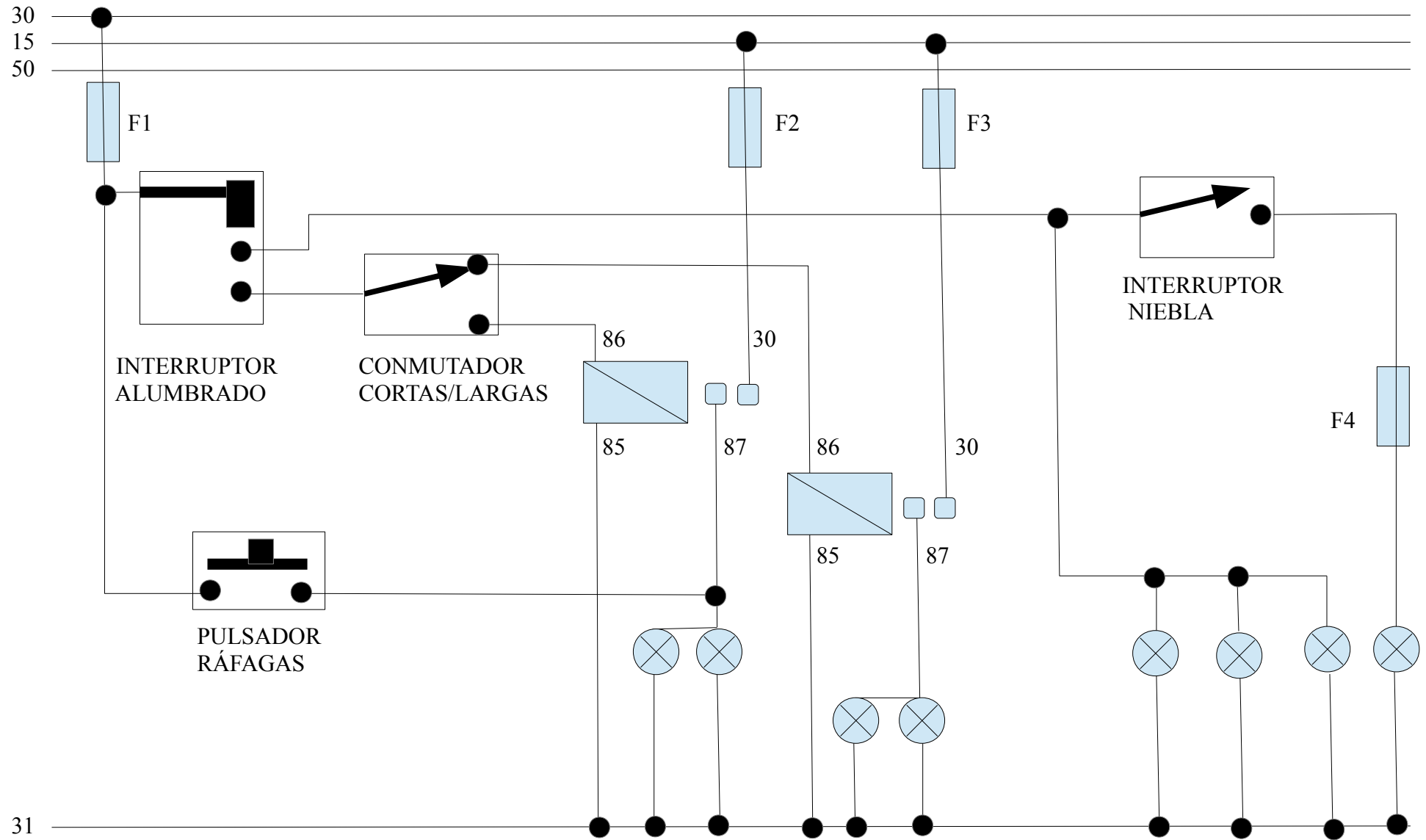

### 3. CIRCUITOS DE INTERMITENCIA:

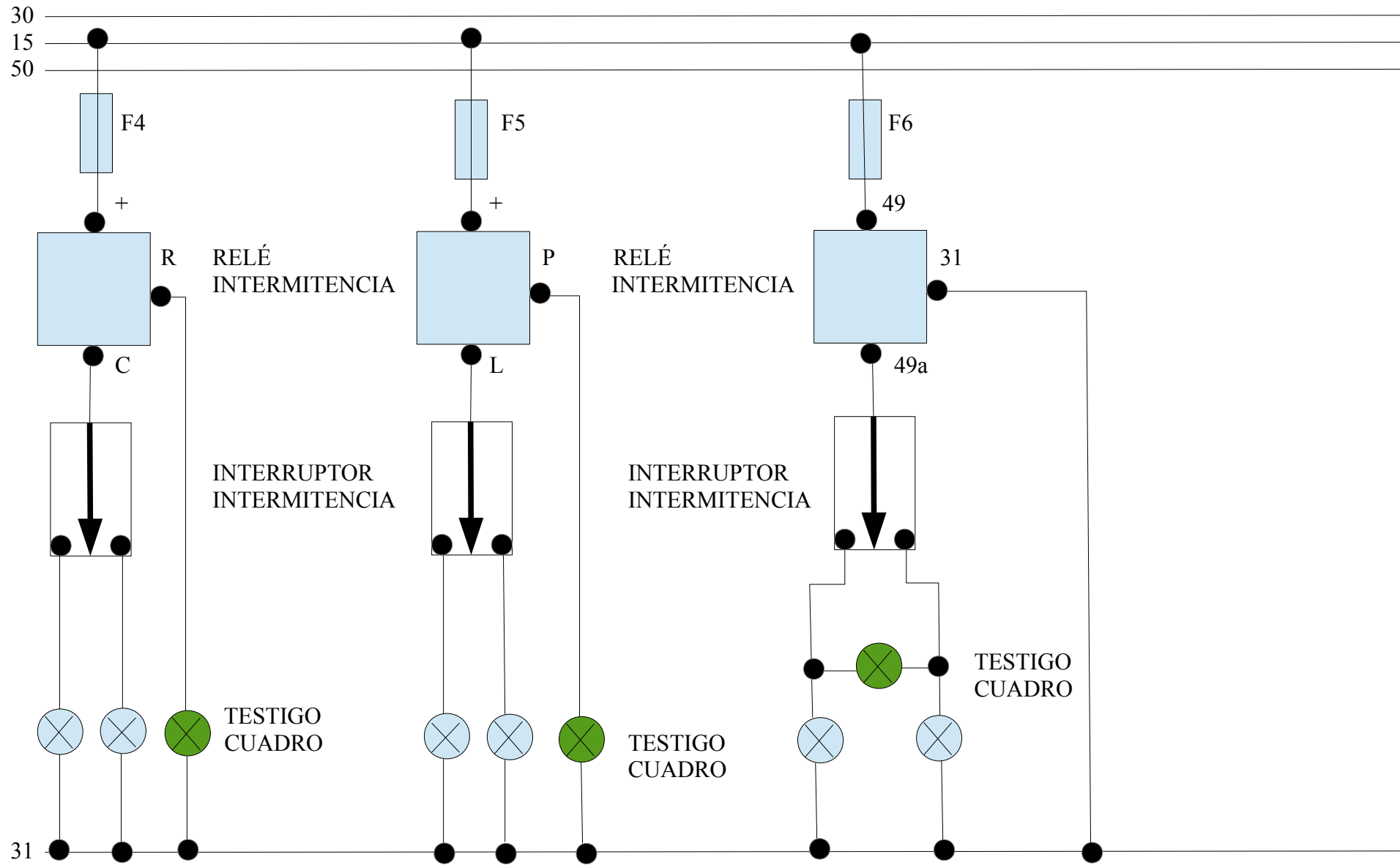

#### 4. INTERMITENCIA DE EMERGENCIA:

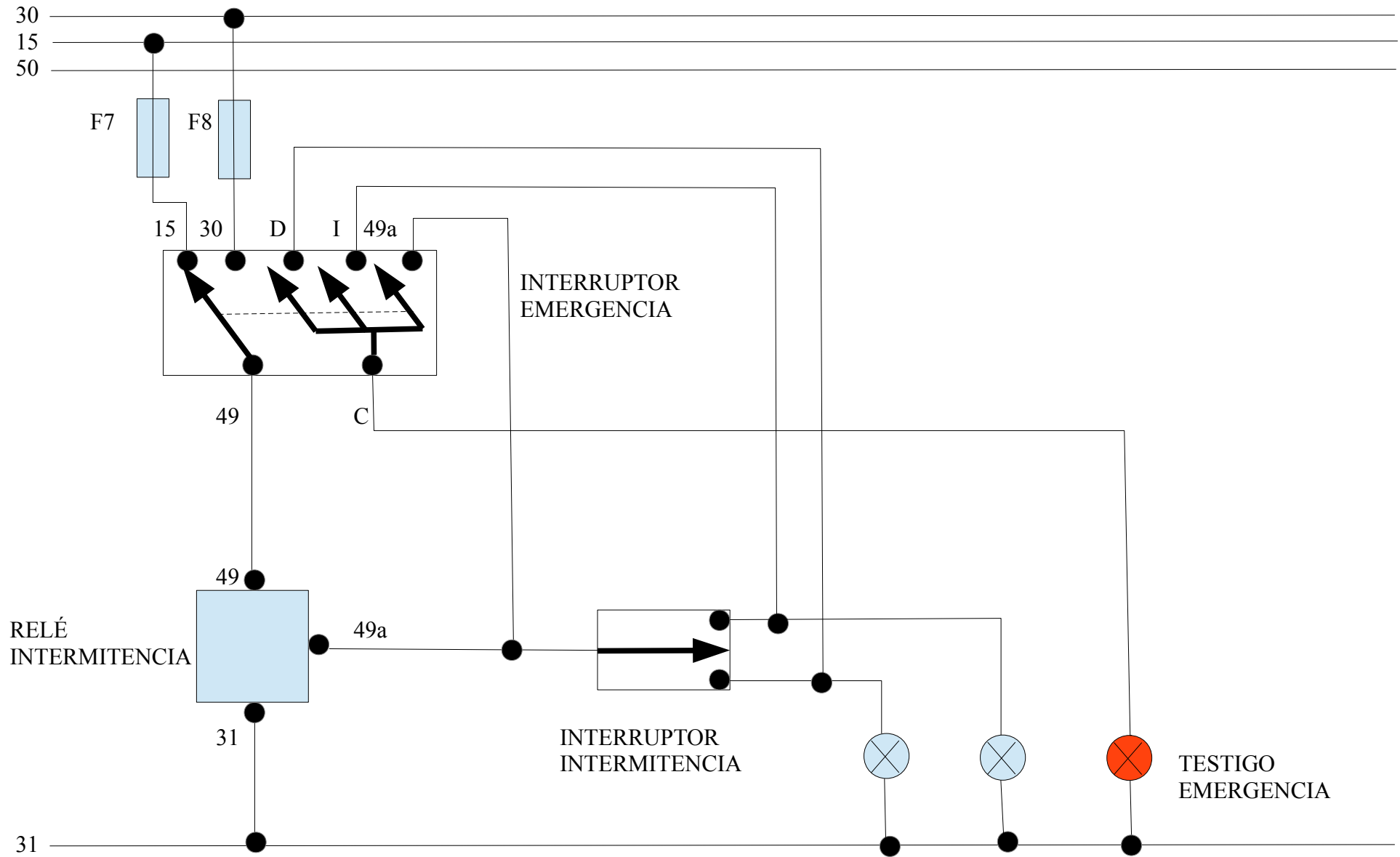

5. LIMPIAPARABRISAS:

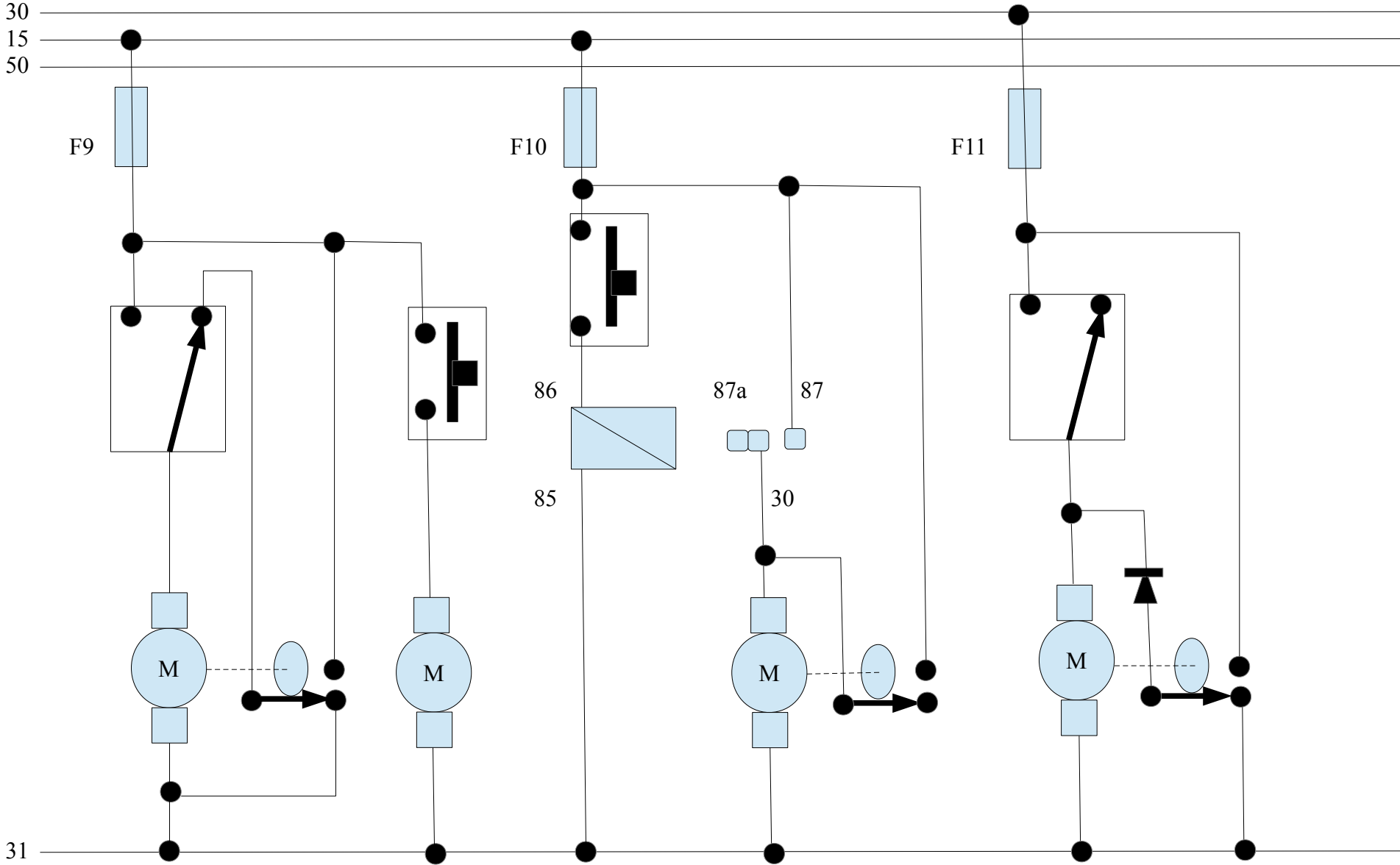

## 6. REGULACIÓN CON TRANSISTOR, LUZ CORTESÍA, ALUMBRADO INTERRUPTORES:

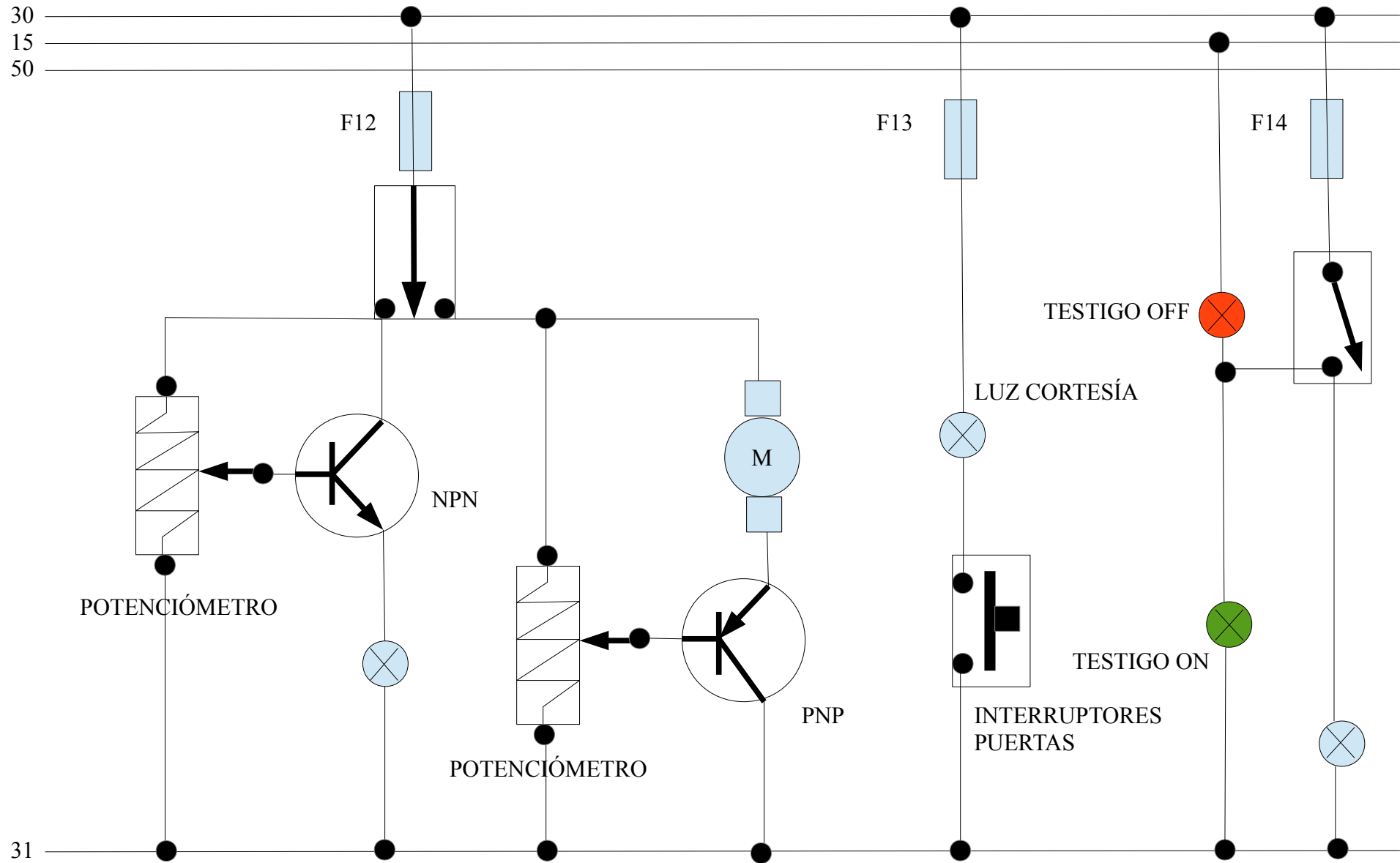

### 7. INDICADORES CUADRO INSTRUMENTOS:

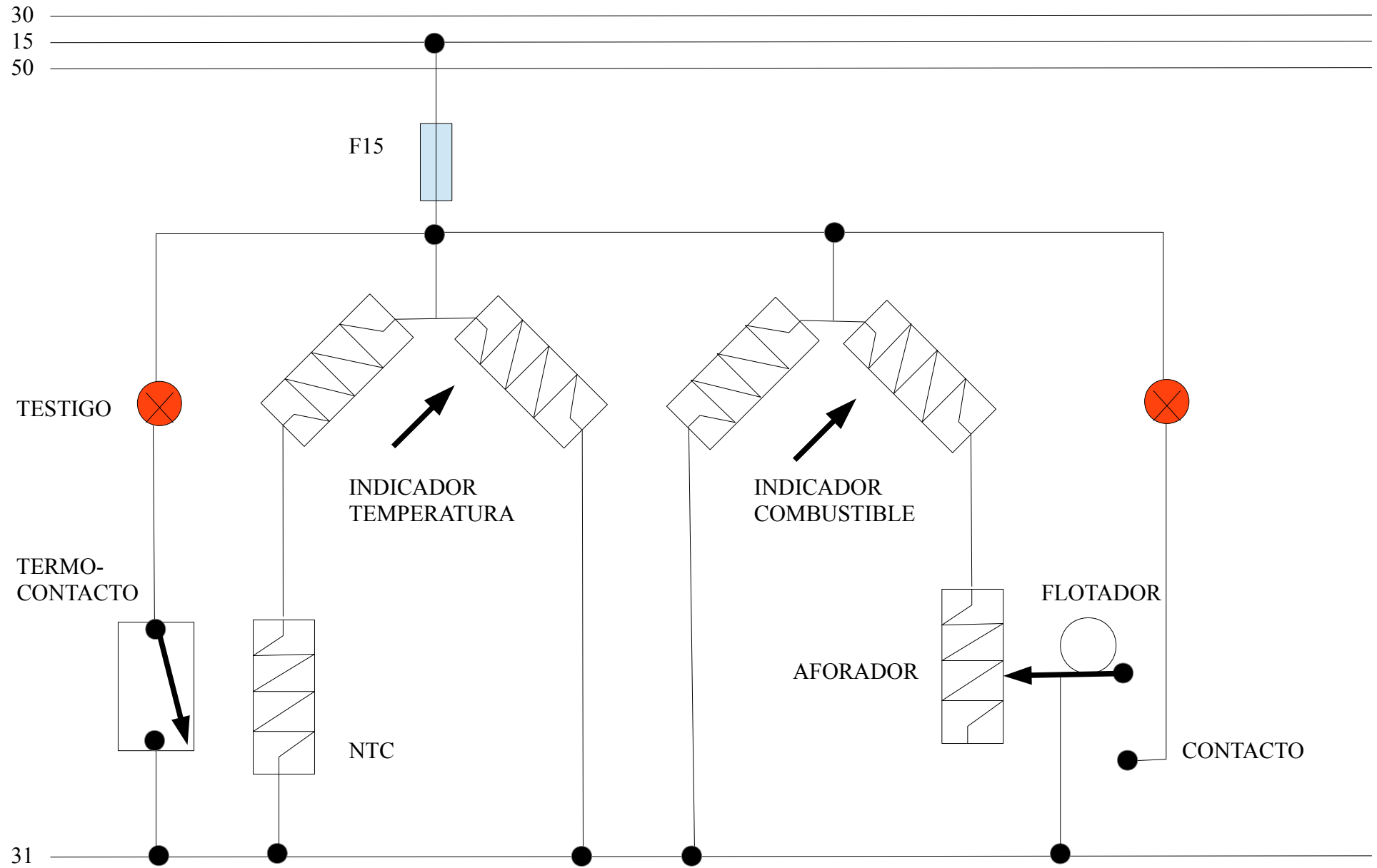

### 8. ELEVACIONES, CIERRE CENTRALIZADO Y TESTIGOS CUADRO:

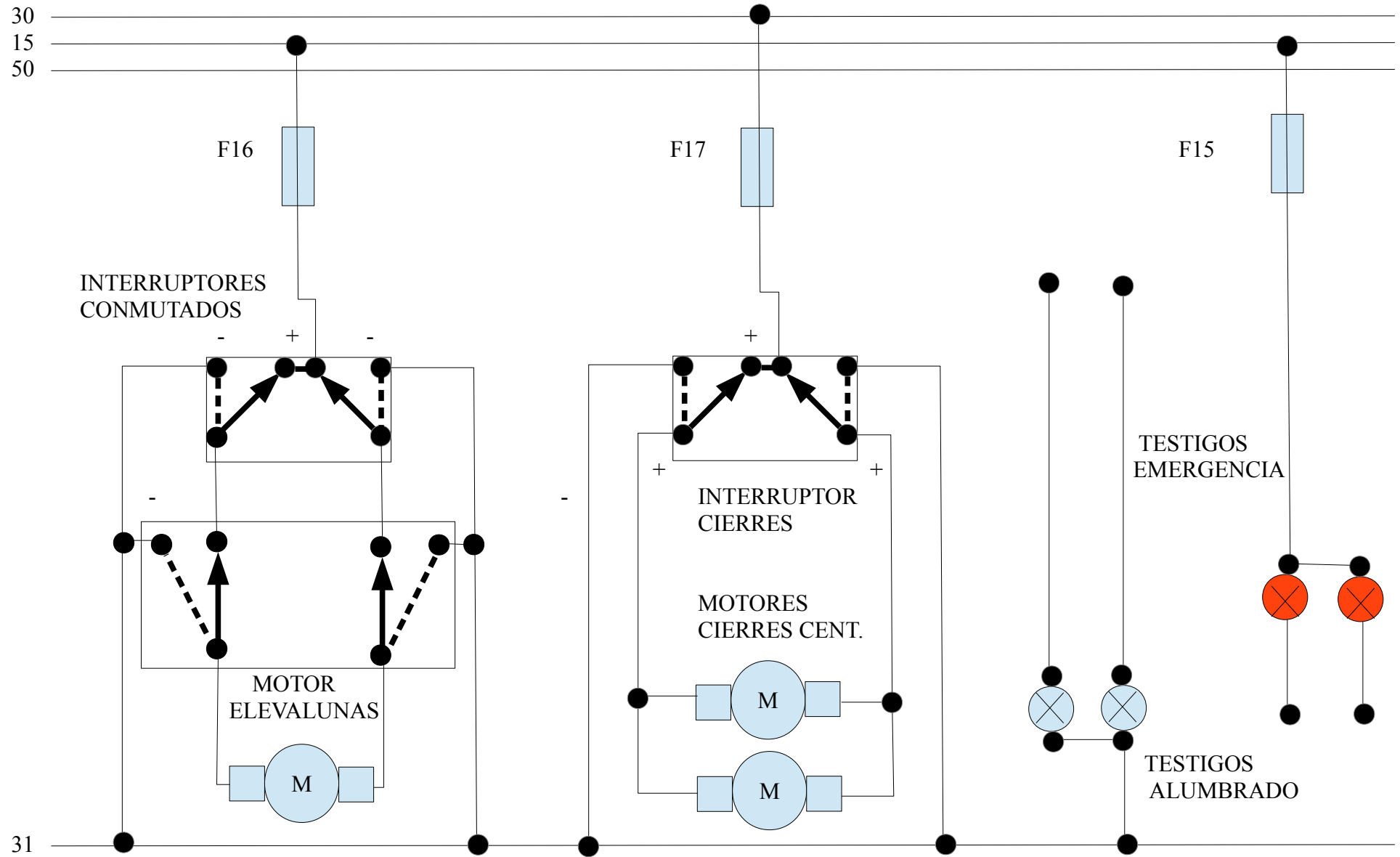

## 9. CIRCUITOS DE ENCENDIDO:

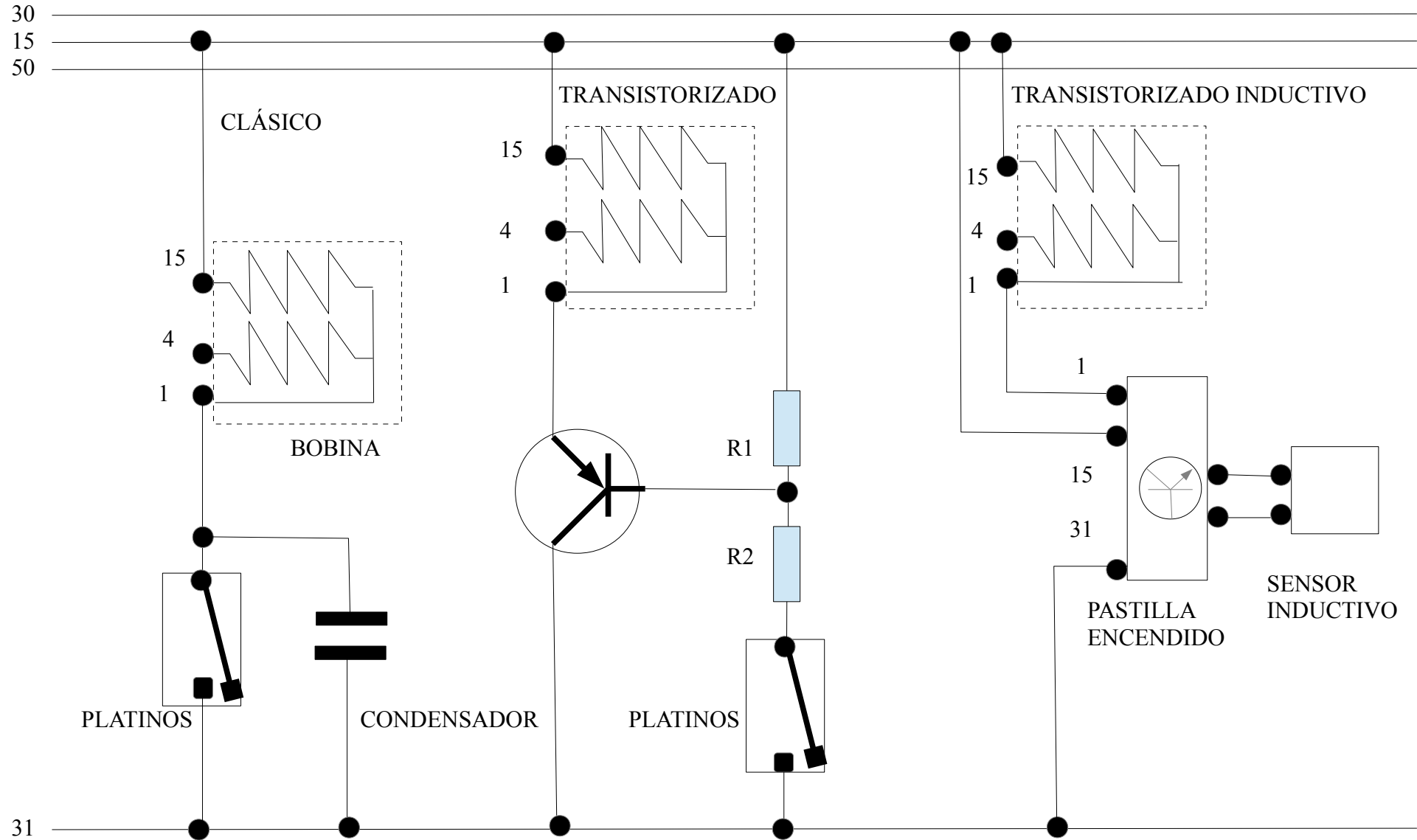

### 10. CIRCUITOS DE ENCENDIDO II.

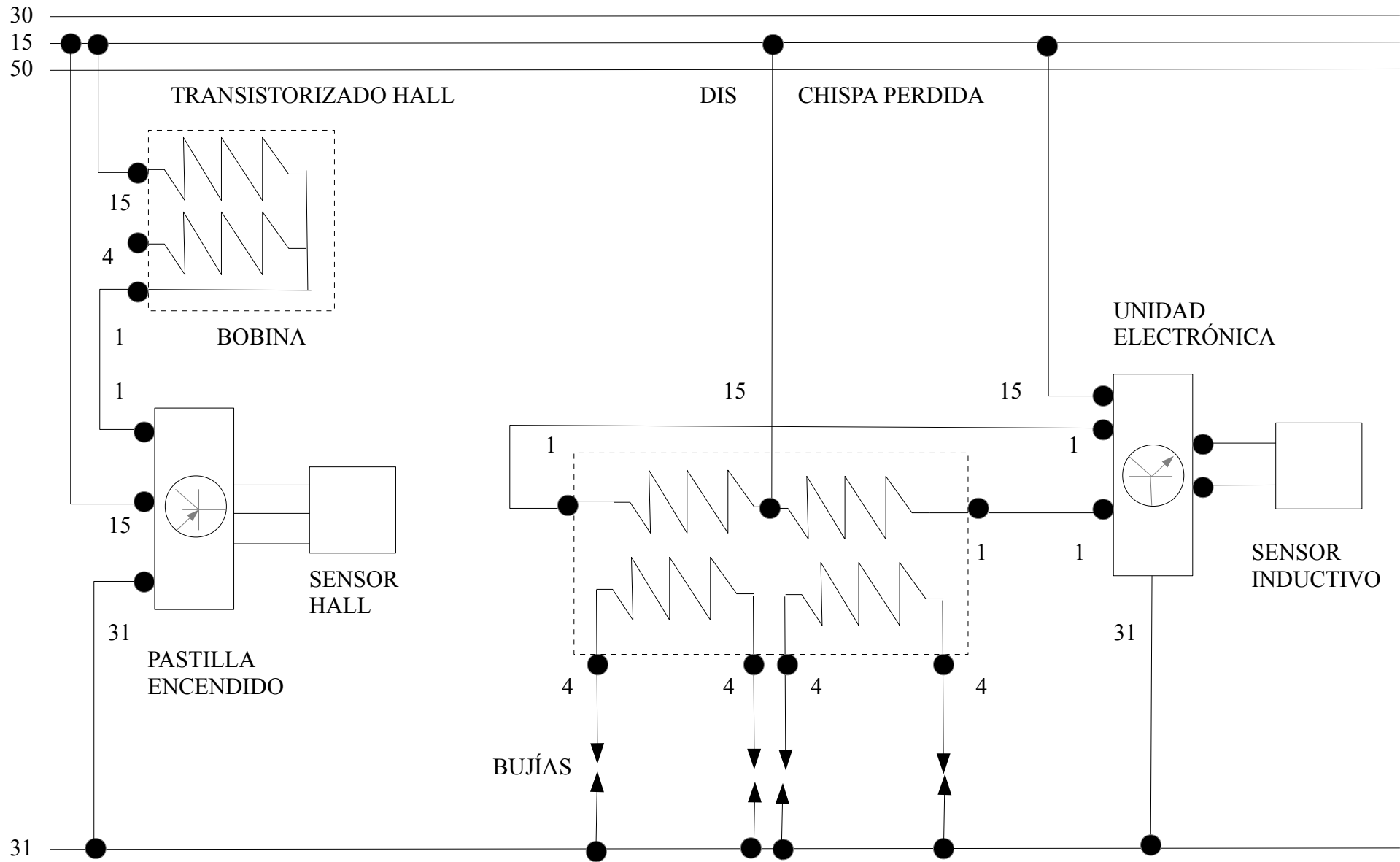

# 11. CIRCUITO MULTIPLEXADO:

