

Fabricación Maqueta didáctica Motor Citroën HDI



CITROËN *Xsara 2*
2.0 HDi

motor diesel de 90

Lectura dos esquema eléctricos

Esquema eléctricos

**Cableados e localización
de componentes**

Lendas



IES Nº1 ORDES



XUNTA DE GALICIA
CONSELLERÍA DE CULTURA, EDUCACIÓN
E ORDENACIÓN UNIVERSITARIA

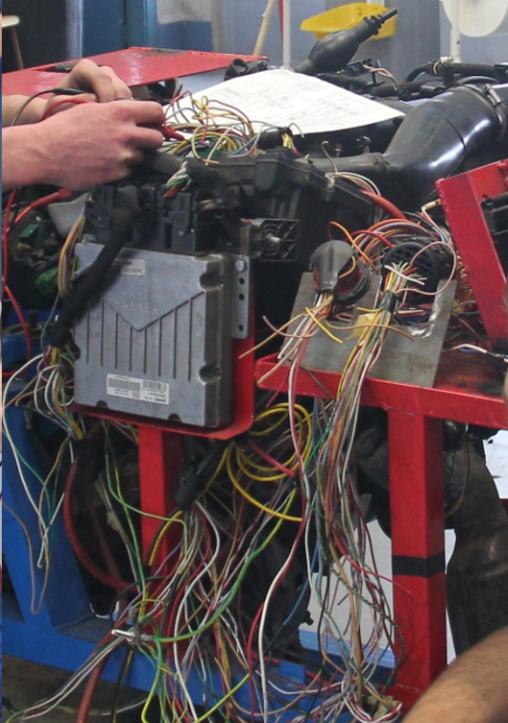



**Lectura dos
esquemas
eléctricos**

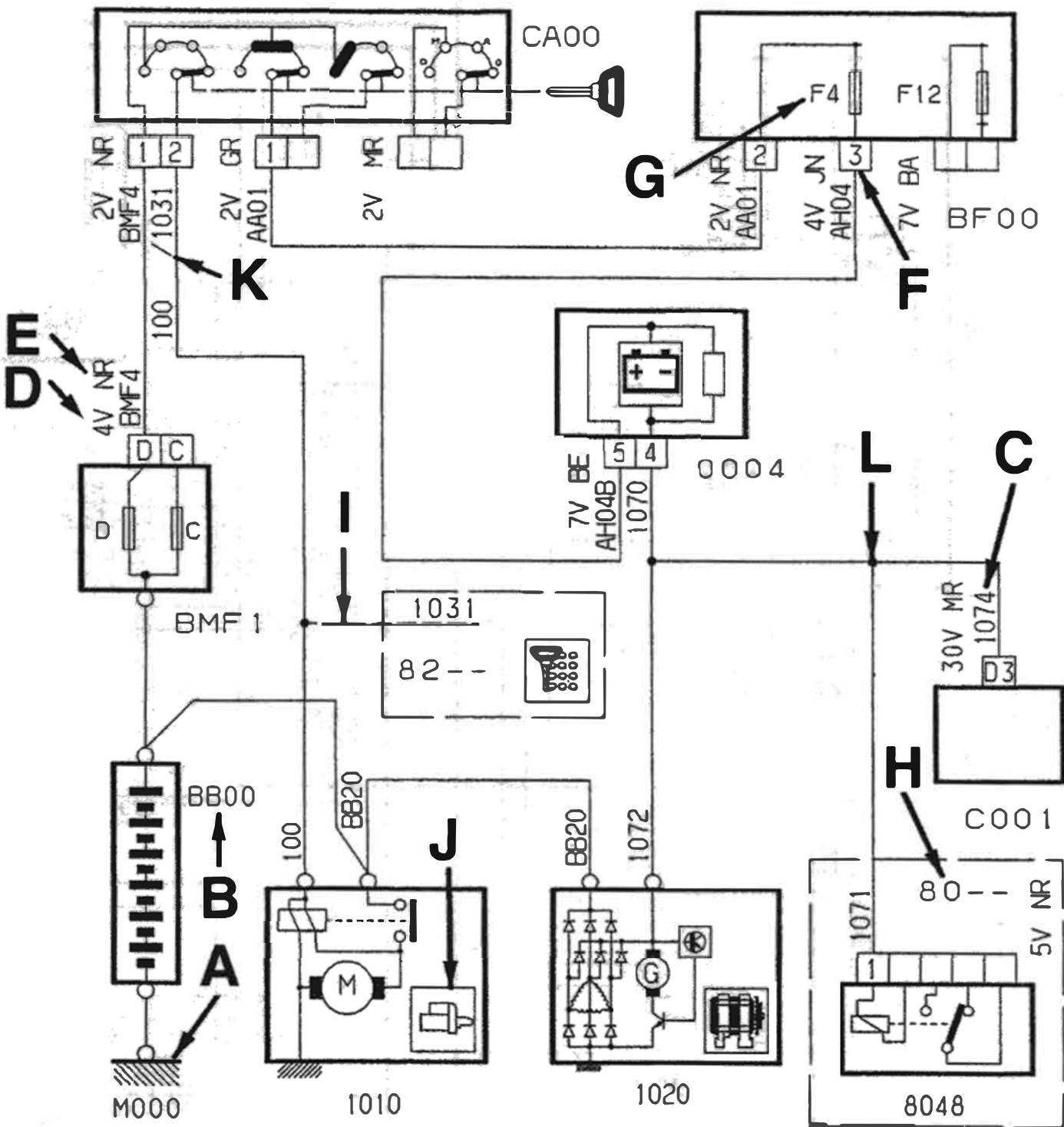

LECTURA DE LOS ESQUEMAS ELECTRICOS

- A. Representación dos puntos de masa - B. Identificación de órgano - C. Número do cable -
- D. Número de vías do conector - E. Color do conector - F. Número do terminal do conector -
- G. Número do fusible - H. Número de identificación da función a remitirse
- DI. Representación según equipo - J. Símbolo do órgano - K. Cables unidos - L. Soldadura

Esquemas eléctricos

1.-Arquitectura eléctrica

2.-Arquitectura electrónica

3.-Grupo Motor-propulsor

4.-Axuda a conducción

5.-Sinalización e iluminación

6.-Información conductor

7.-seguridade

8.-Dispositivos de mando eléctrico

9.-Confort habitáculo

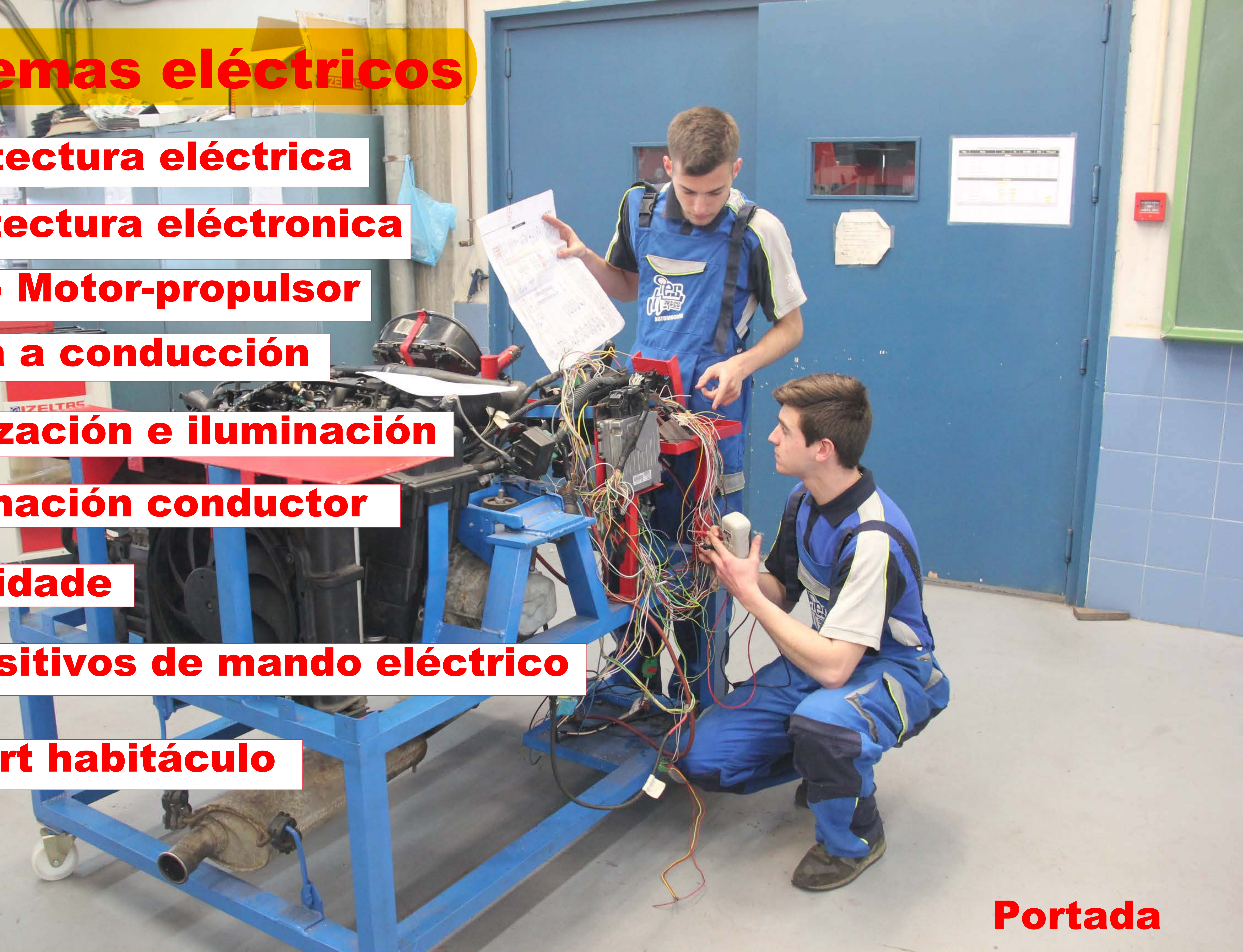

Motor RHY

Motor RHZ con caixa automática

Motor RHZ

**Motor arranque
-Alternador**

Habitáculo
Compartimento motor

Fusibles

Esquemas eléctricos

Arquitectura eléctrica

INICIO

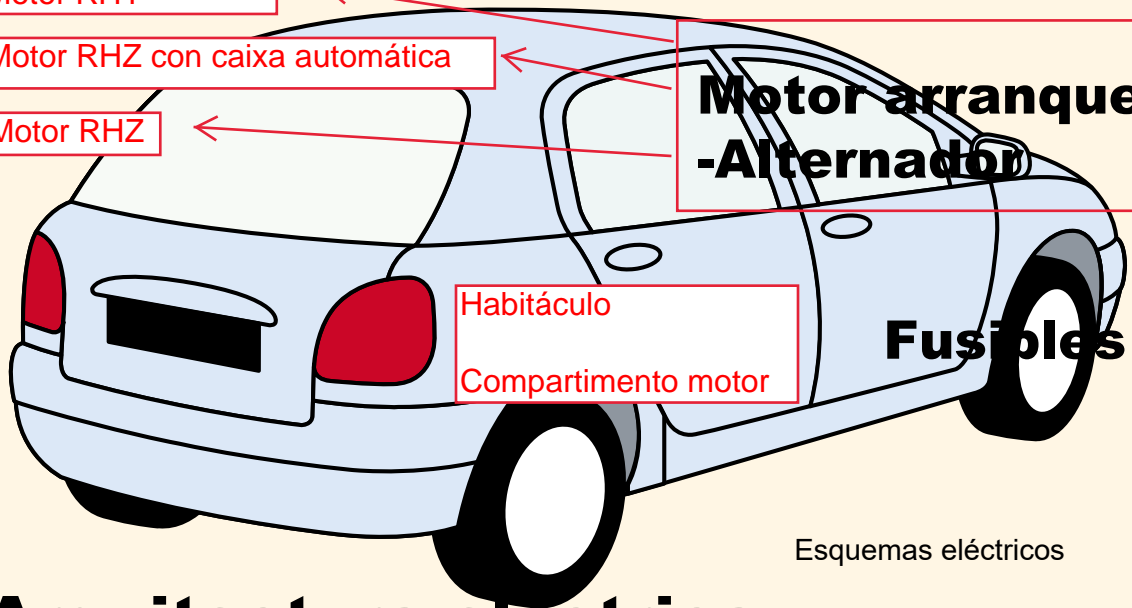

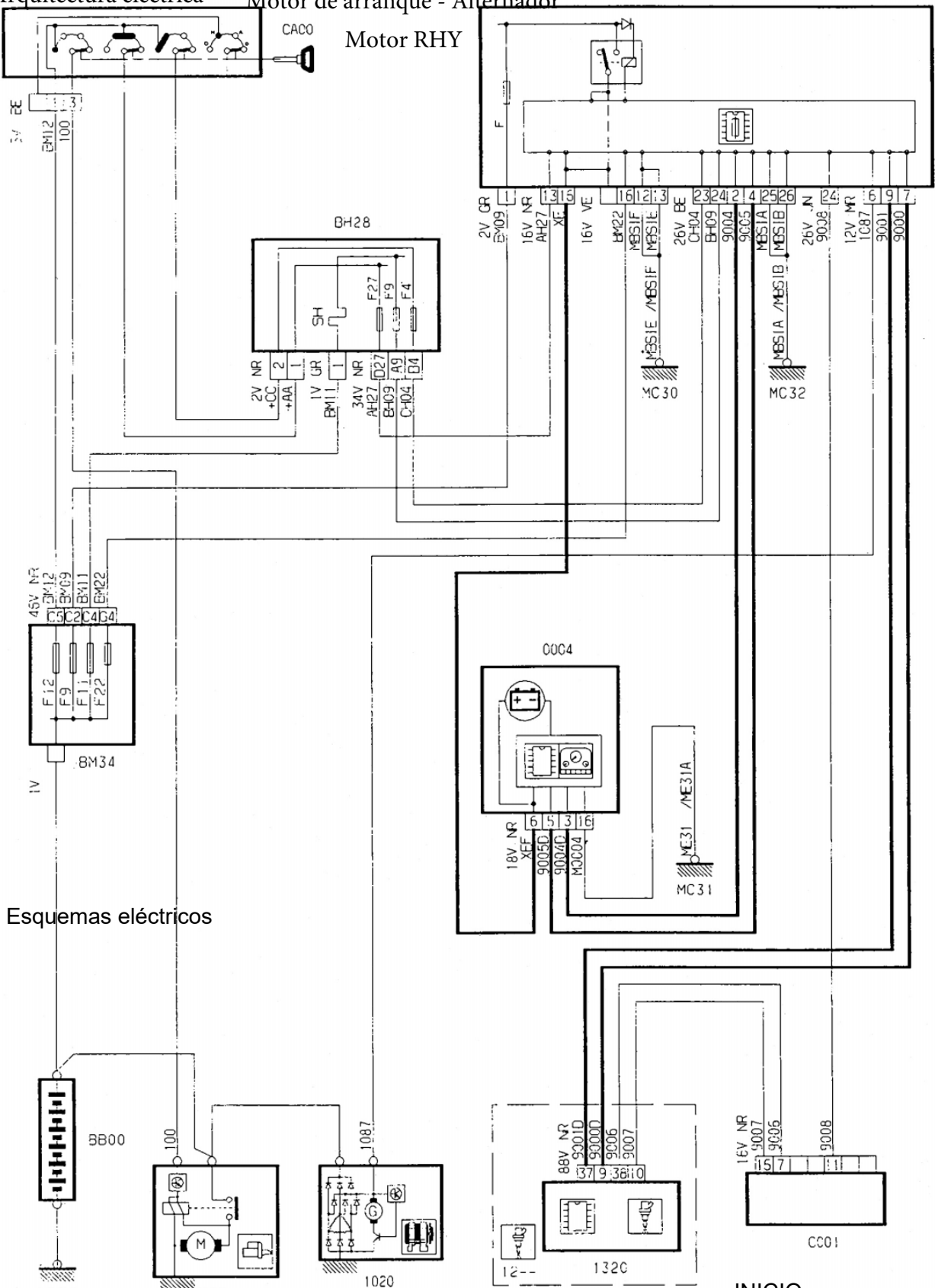

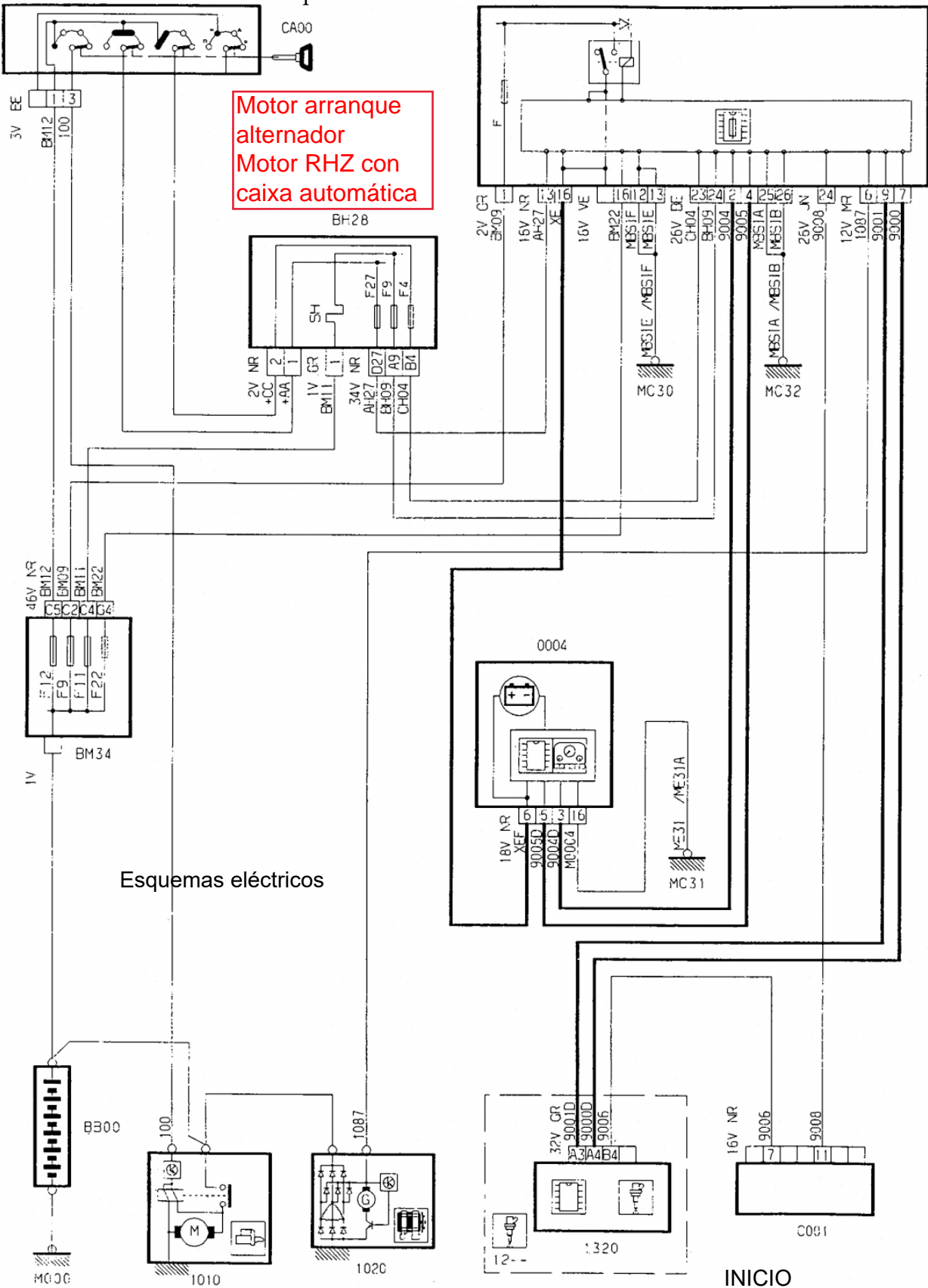

Motor arranque
alternador
Motor RHZ con
caixa automática

Esquemas eléctricos

INICIO

Motor arranque
alternador
Motor RHZ

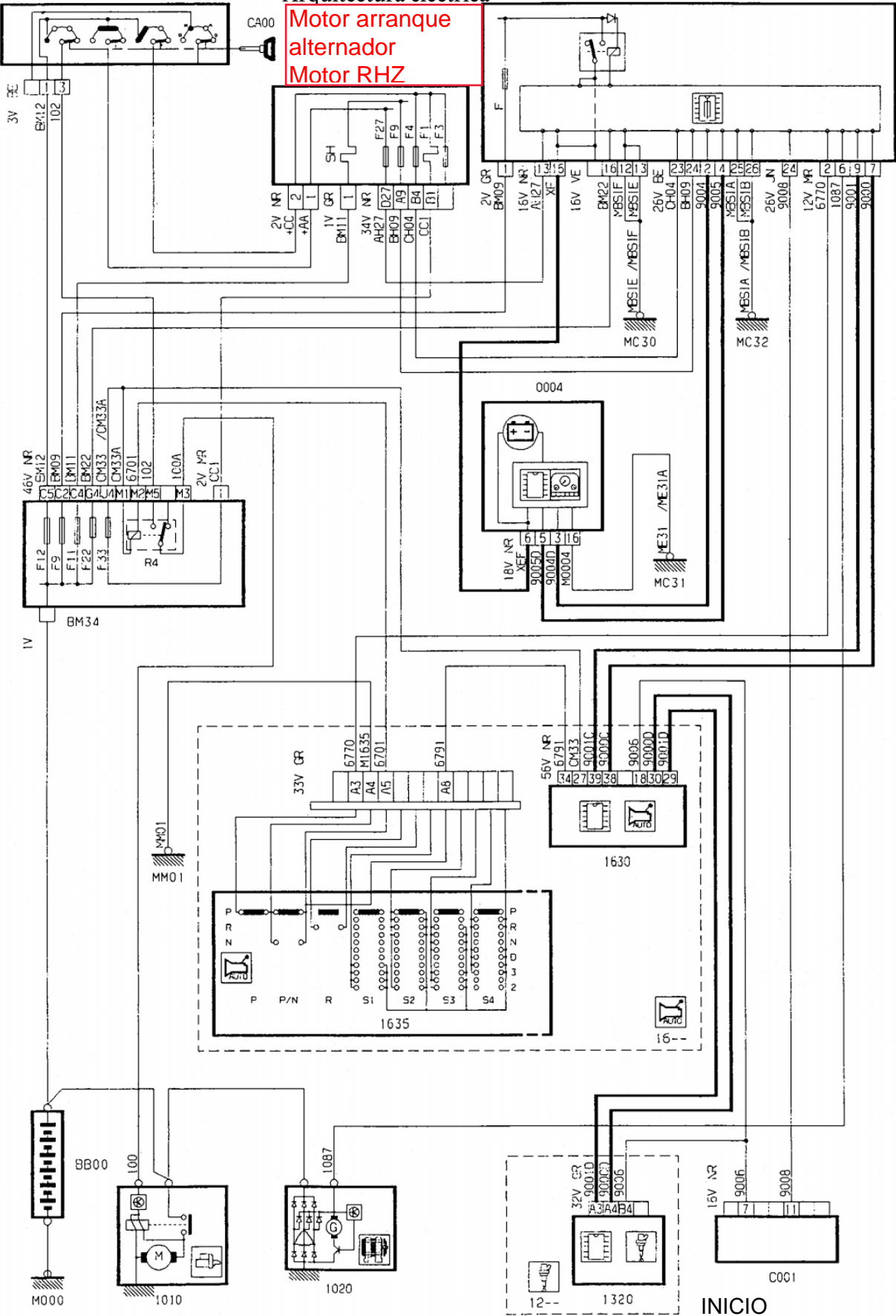

INICIO

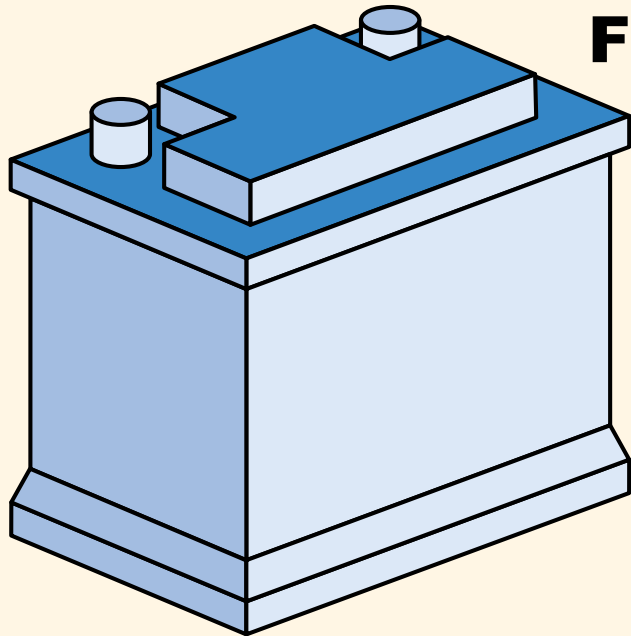

Fusibles

Habitáculo BH28

**Compartimento motor
BM3436**

INICIO

2VNR

34VNR

+CC
+AA

2
1

2VBE

+CC
+BB

2
1

Fusibles Habitáculo BH28

1V GR

+BB

1

Fusibles

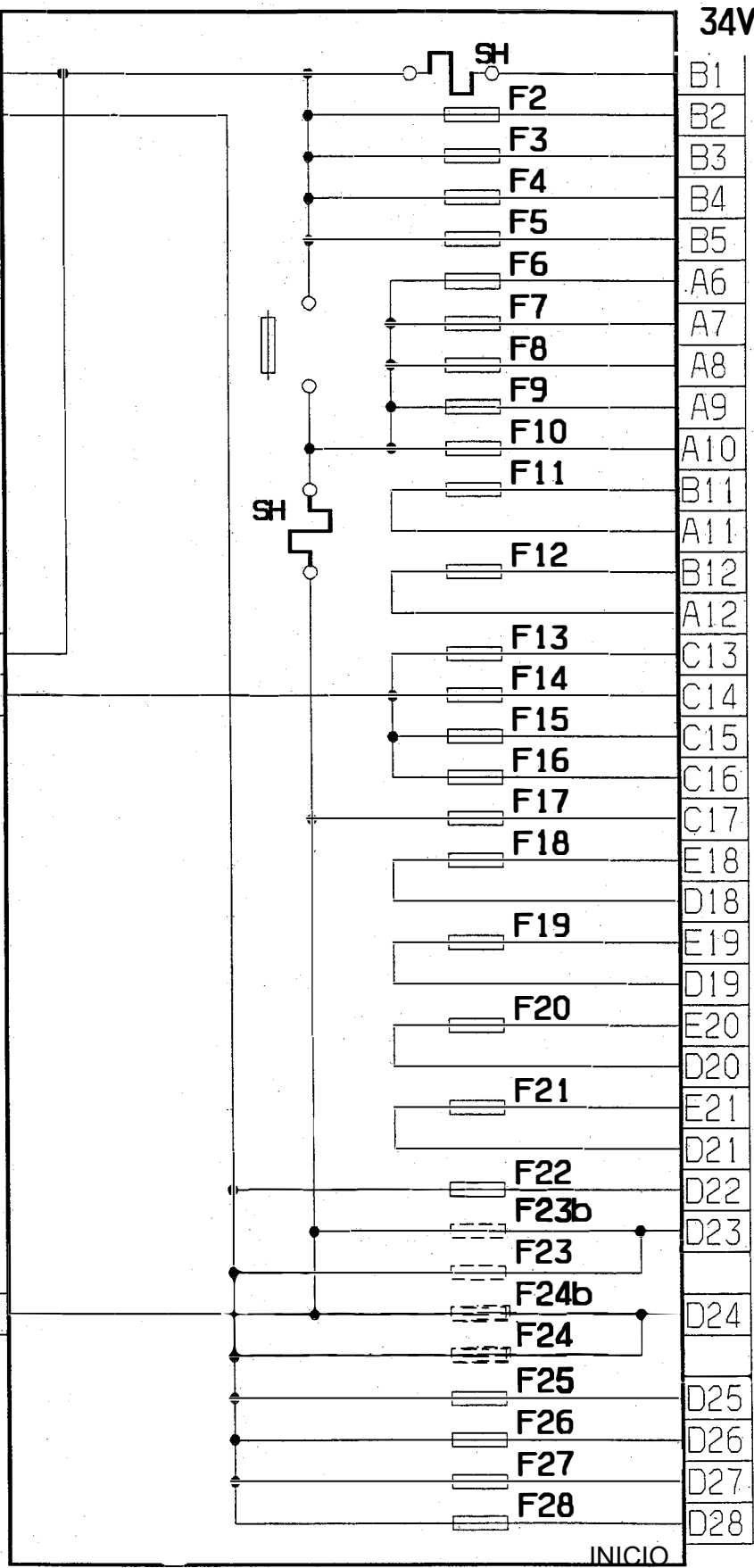

INICIO

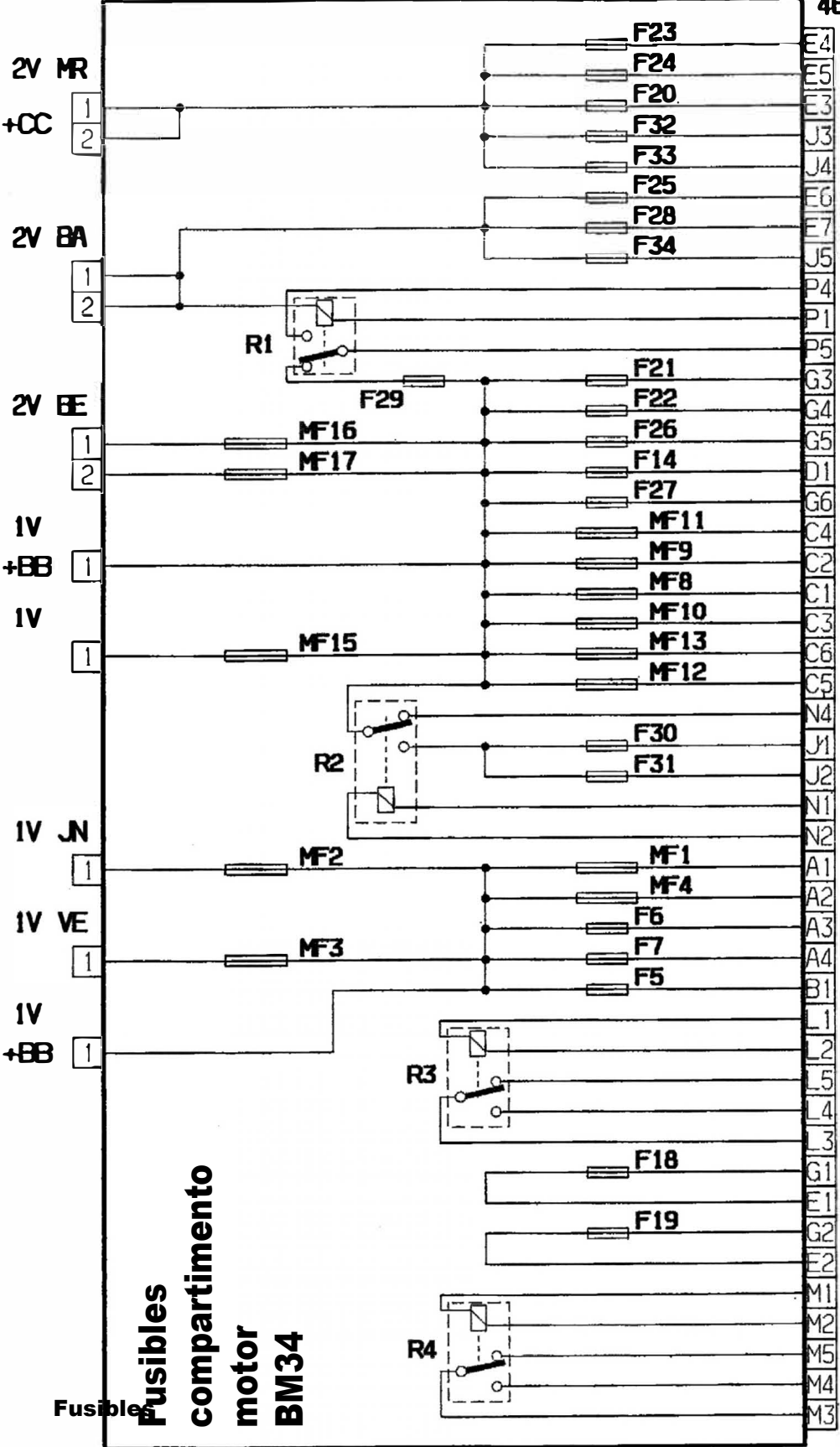

**Fusibles
compartimento
motor
BM34**

Fusibles

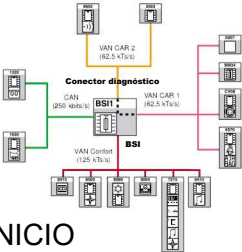

INICIO

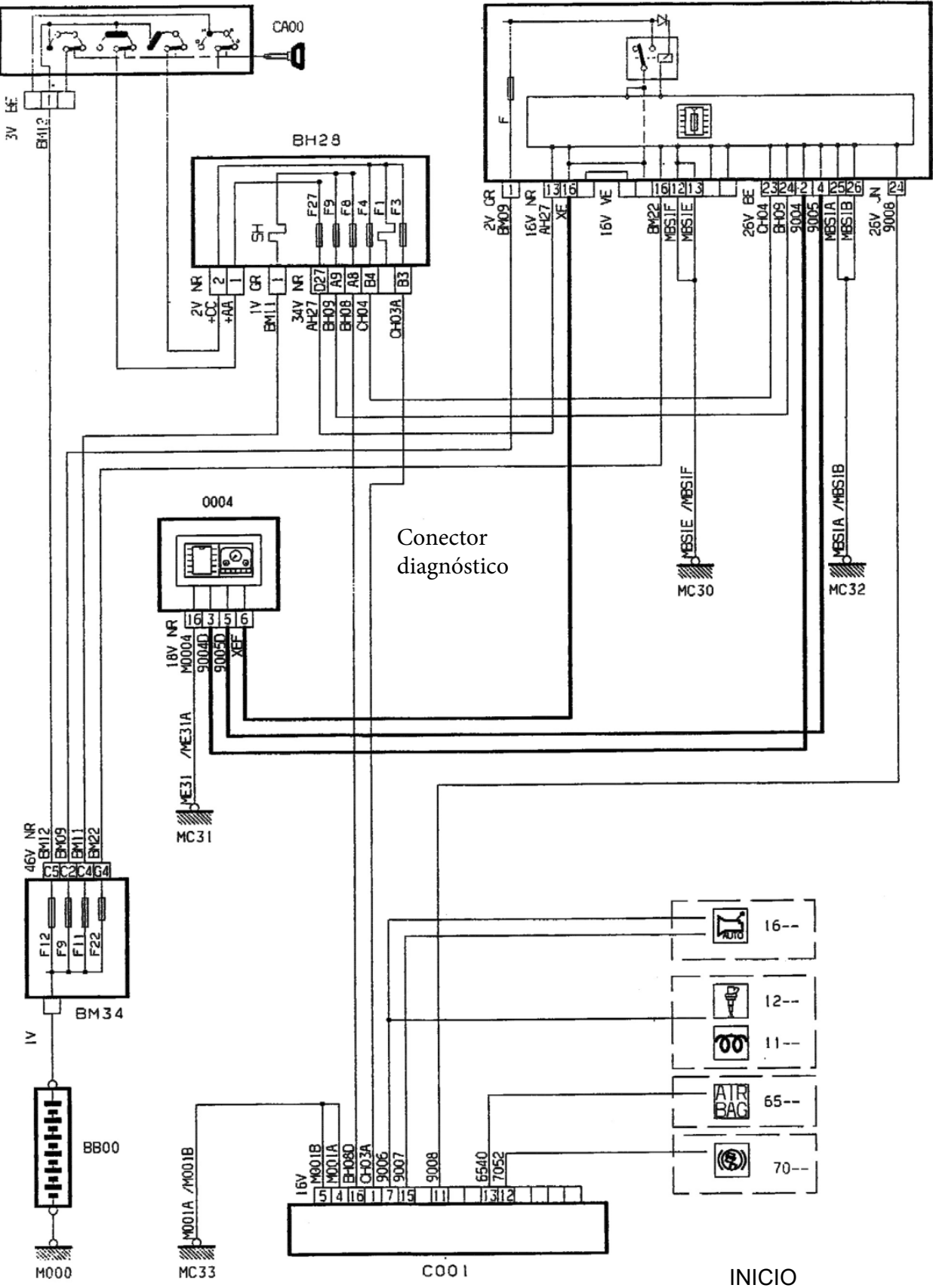

Conector diagnóstico

INICIO

C001

3V BF

CA00

BH28

0004

46V NR

1V

18V NR

M0004

M0004

M001B

M001A

BH08

CH03A

M000

MC33

16V

M001B

M001A

BH08

CH03A

9006

9007

9008

6540

7052

2V GR

BM09

16V NR

AH27

16V VE

BM22

MBS1F

MBS1E

26V BE

CH04

BH09

9004

9005

MBS1A

MBS1B

26V JN

9008

MBS1E /MBS1F

MC30

MBS1A /MBS1B

MC32

MBS1A /MBS1A

MC31

16--

12--

11--

AIR BAG

65--

70--

BB00

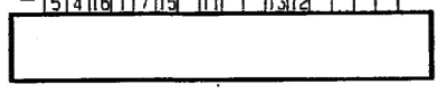
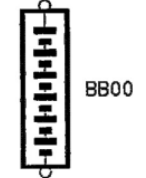
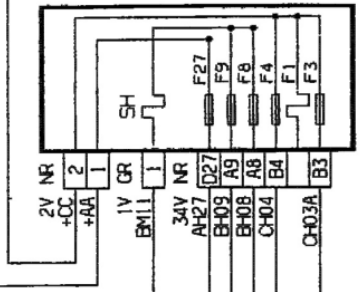
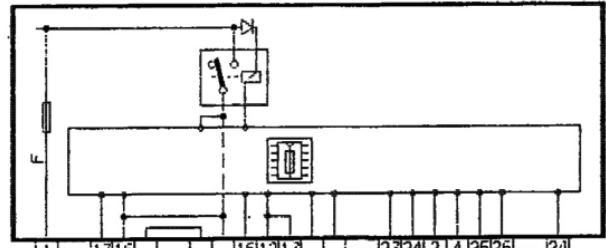
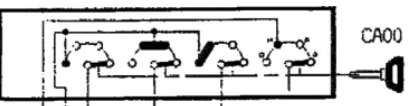
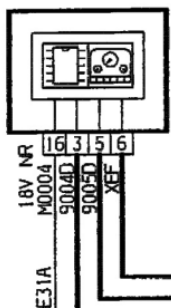
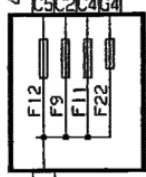
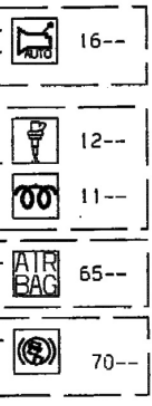

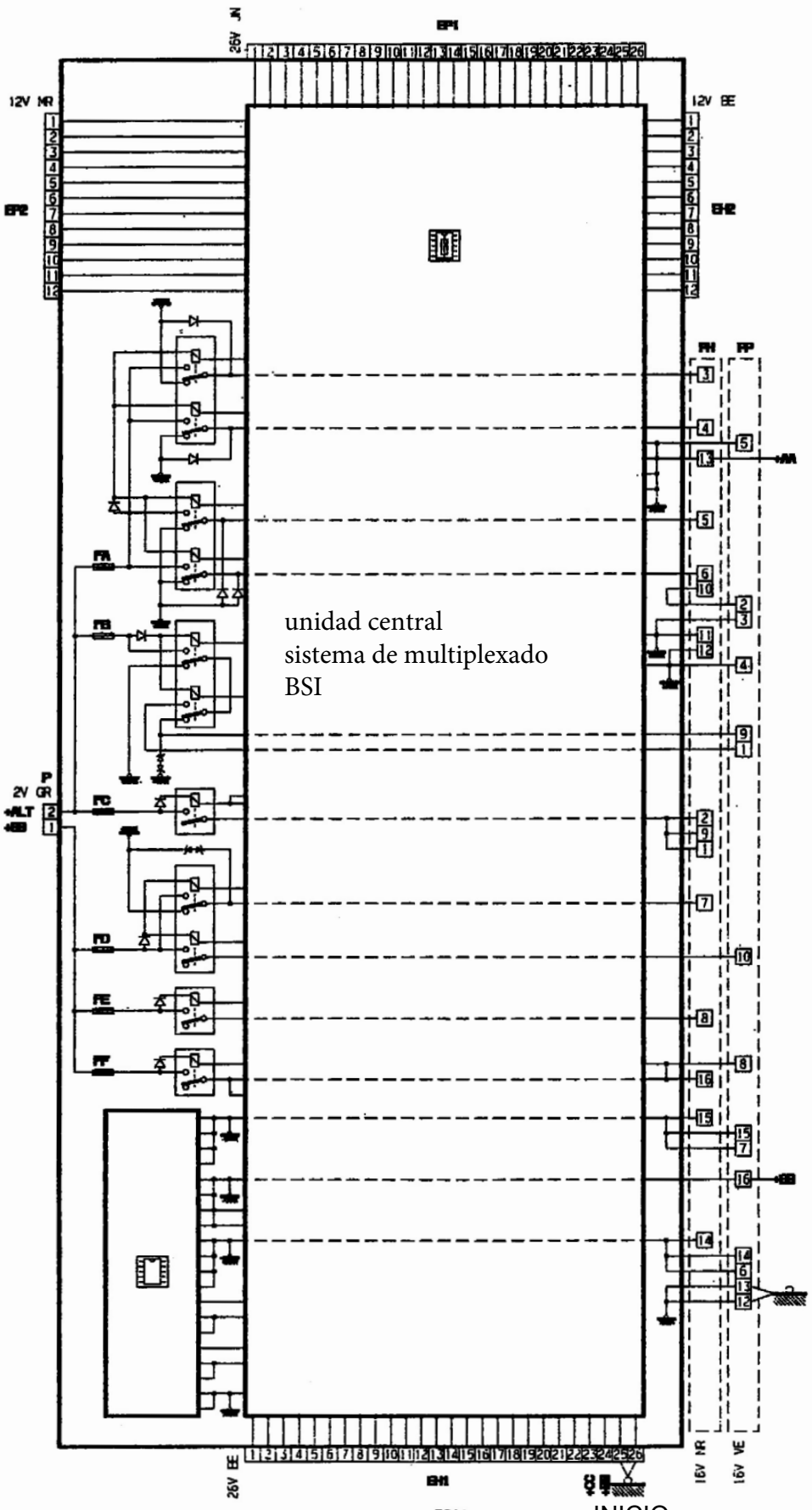

BSI I

INICIO

Inyección

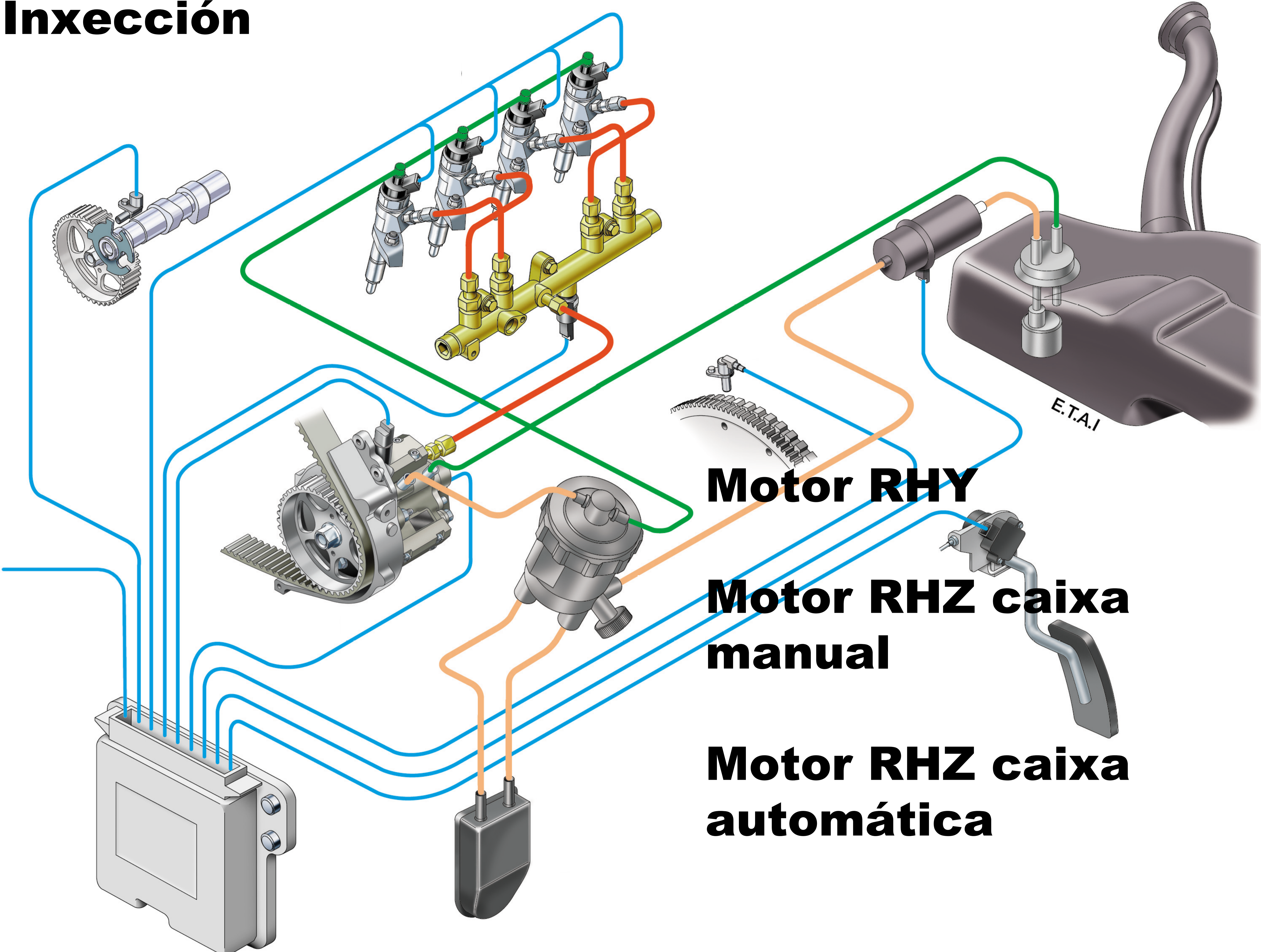

Motor RHY

Motor RHZ caixa manual

Motor RHZ caixa automática

Inicio

Xestión motor Inxección RHY

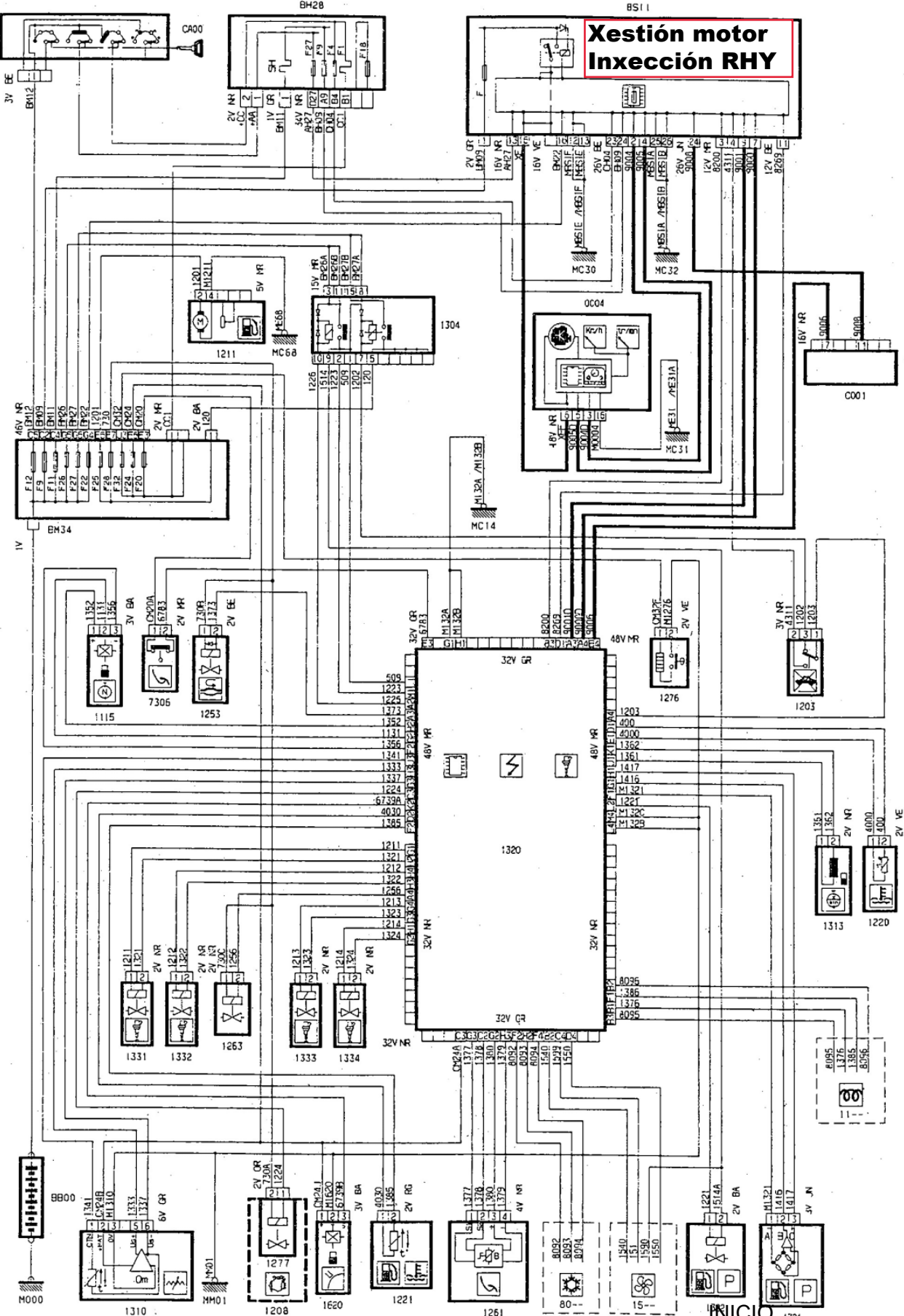

INICIO 131

Prequentamento

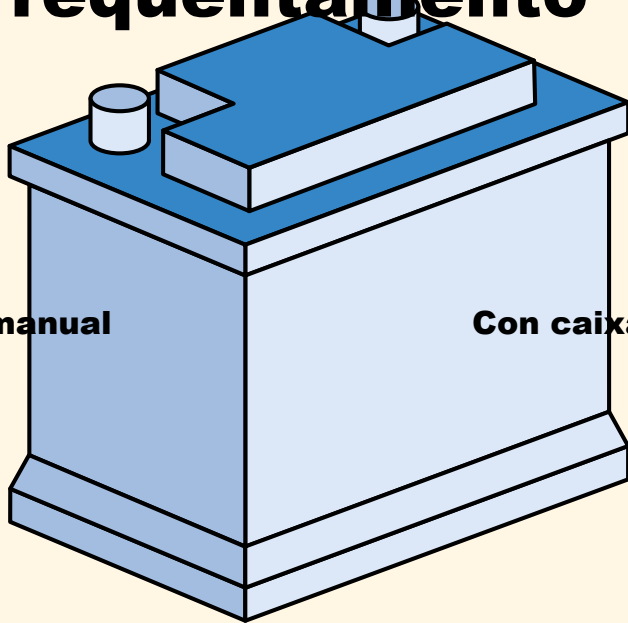

Con caixa manual

Con caixa automática

INICIO

Prequentamento Caixa manual

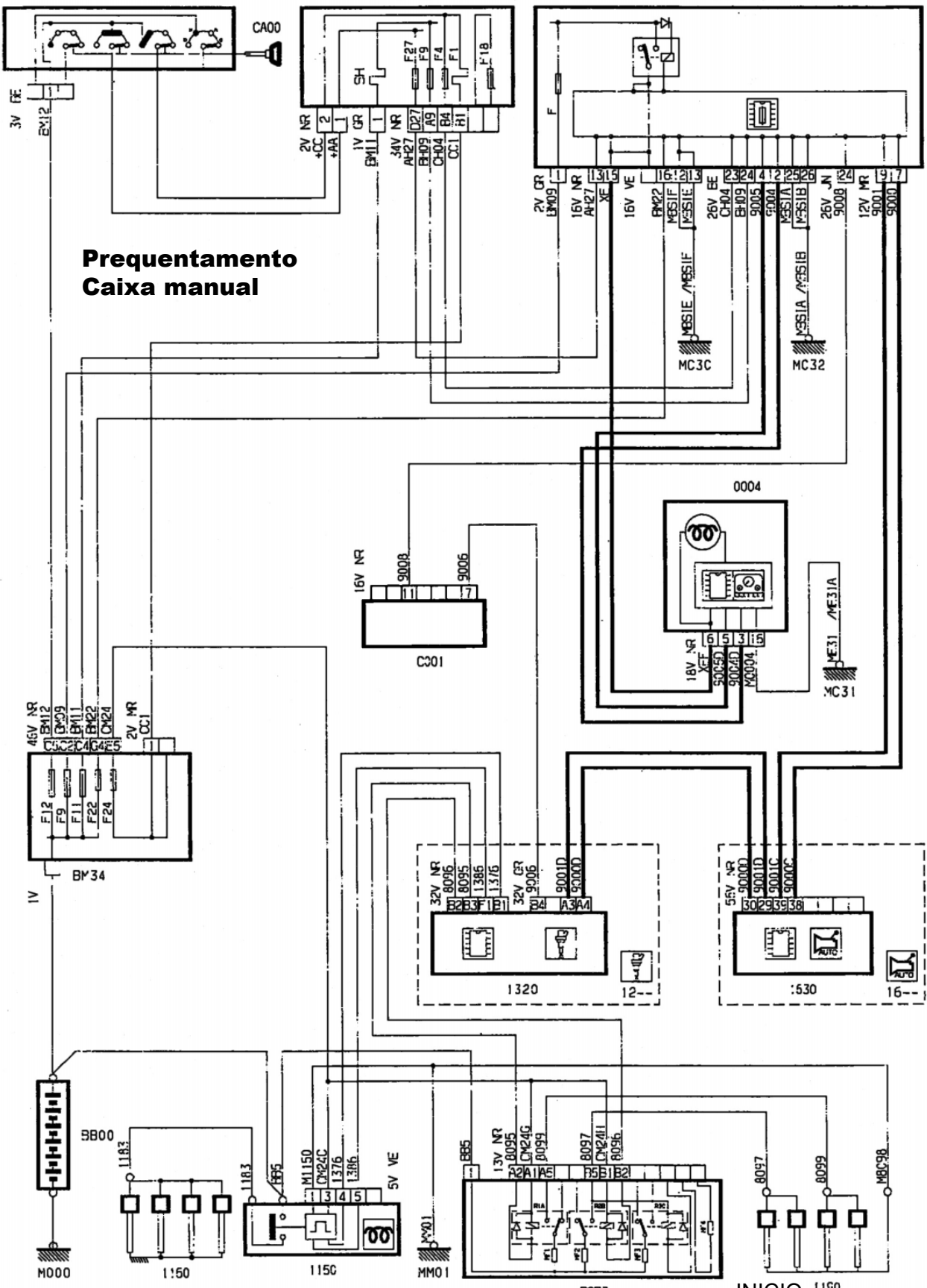

H000

1:50

1:50

MM01

BCP3

INICIO 1:50

8097

8099

MBC98

32V NR
8096
8095
1386
1376
32V GR
9006
9005
9004
9003
9002
9001

1320

9001D
9000D

12

56V NR
9000
9001D
9001C
9000C

:530

16

16V NR

C301

9008
9006

0004

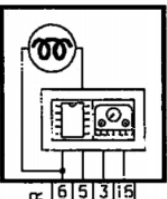

ME31 / ME31A
MC31

3V FE

EM12

CA00

2V NR
+CC
+AA

1V GR
EM11

34V NR
A#27

EH09
A9

CH04
B4

F1
F4

F9
F27

F18
SH

2V GR
EM09

16V NR
A#27

16V VE
XE

EM22
MES1F
MES1E

26V BE
CH04

EH09
K2

9005
K4

9004
K2

MES1A
MES1B

46V NR
EM12
EM09
EM11
EM22
EM24

2V MR
CC1

1V

BP34

9B00

1183

1183

5V VE

MM01

M1150
CM24C

1376
1386

8097
CM2411

8096
CM2411

8097
CM2411

8096
CM2411

8097
CM2411

8096
CM2411

8097
CM2411

8096
CM2411

8097
CM2411

8096
CM2411

8097
CM2411

8096
CM2411

Refrigeración motor

Sin climatización

Con climatización

Con climatización e caixa automática

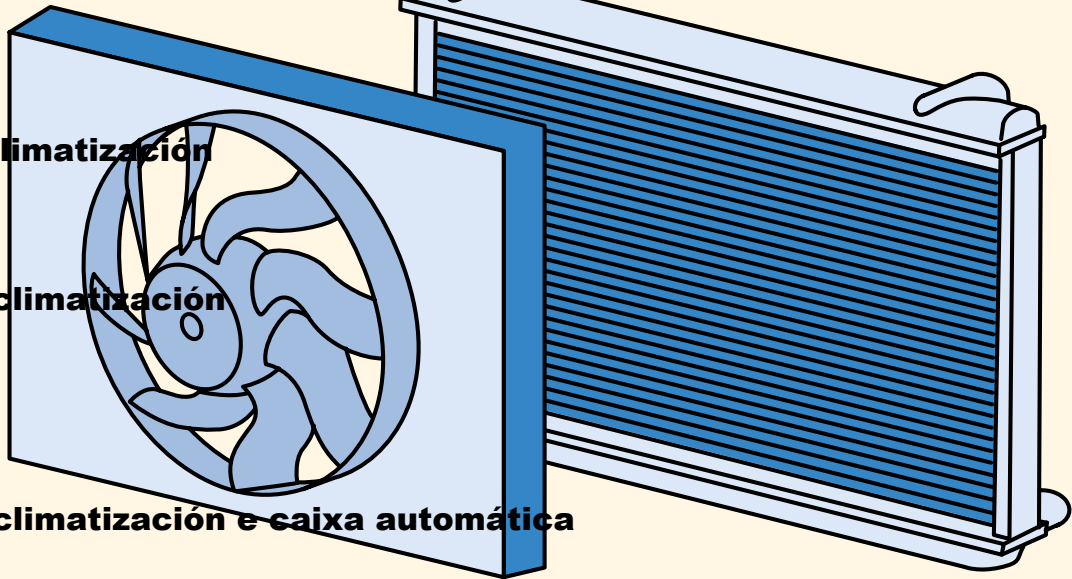

INICIO

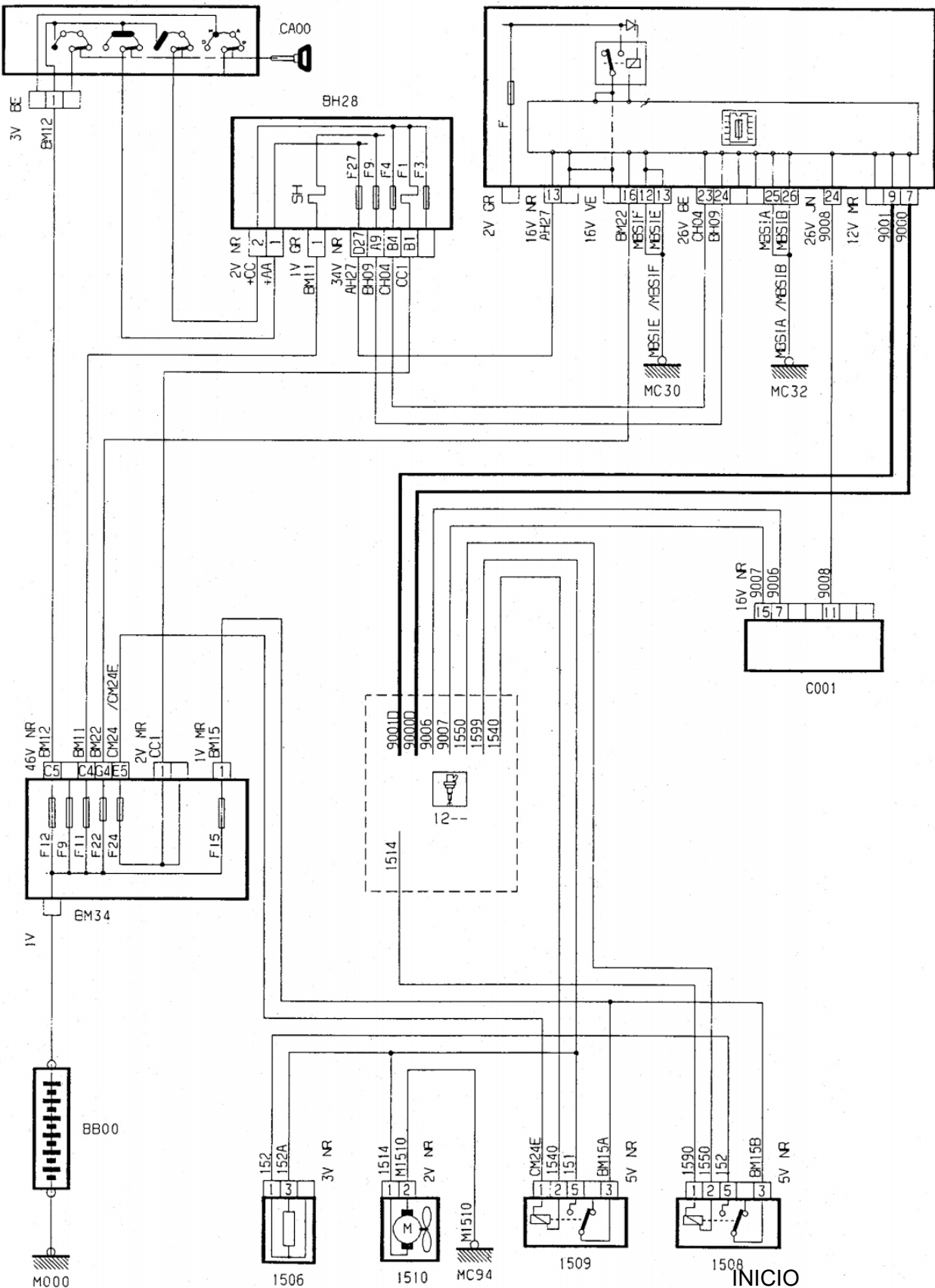

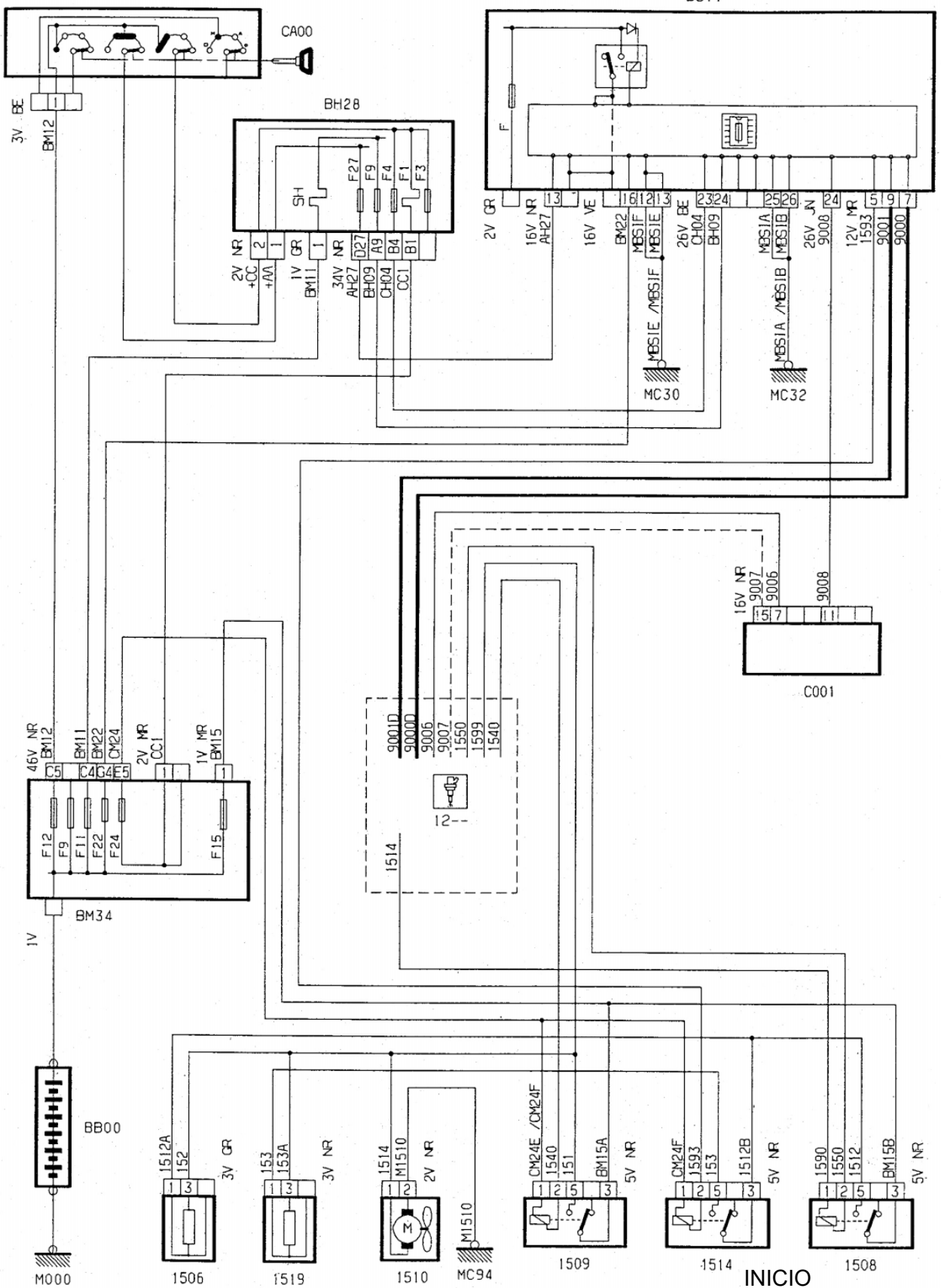

INICIO

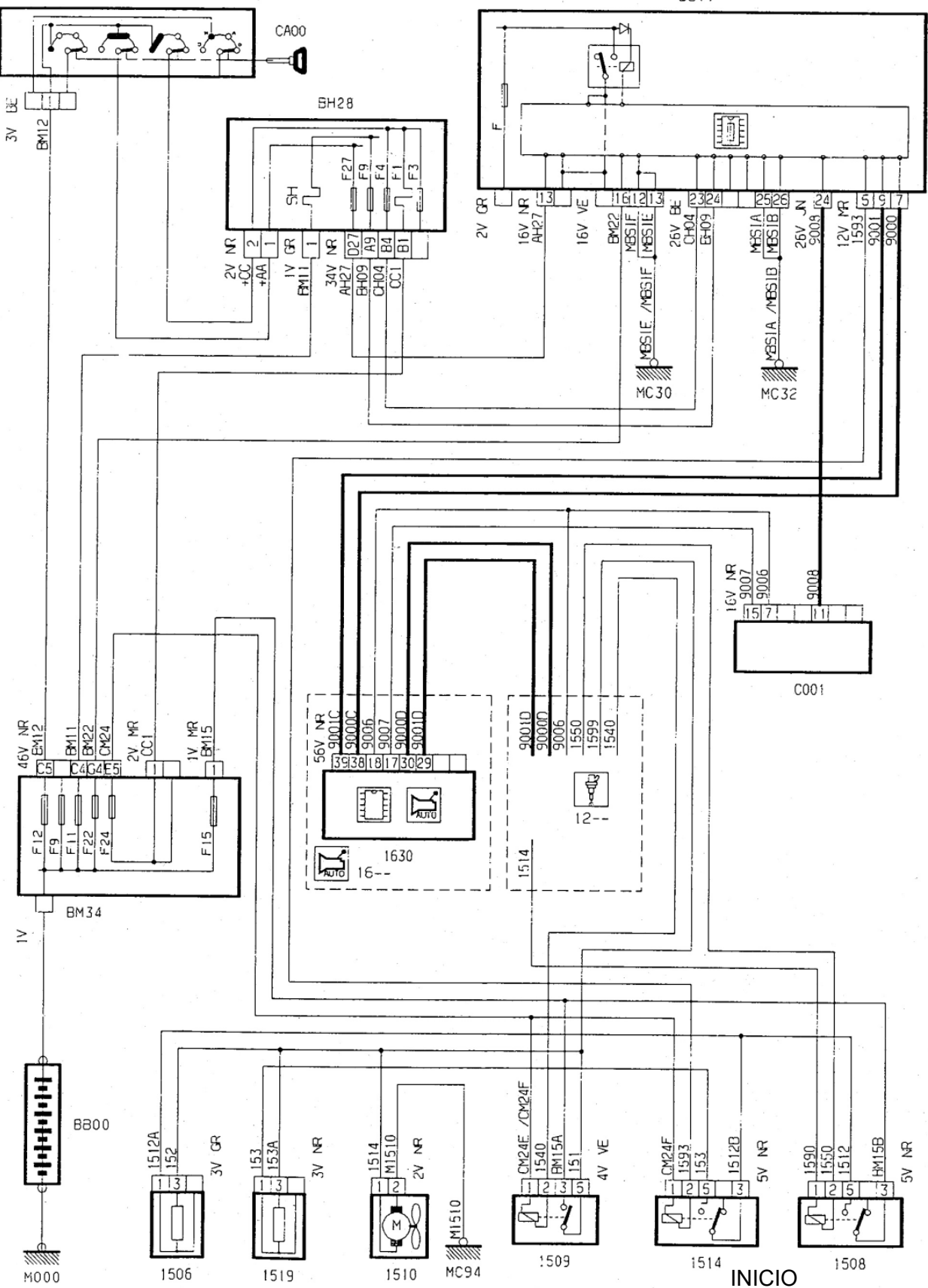

Caixa de cambios automática

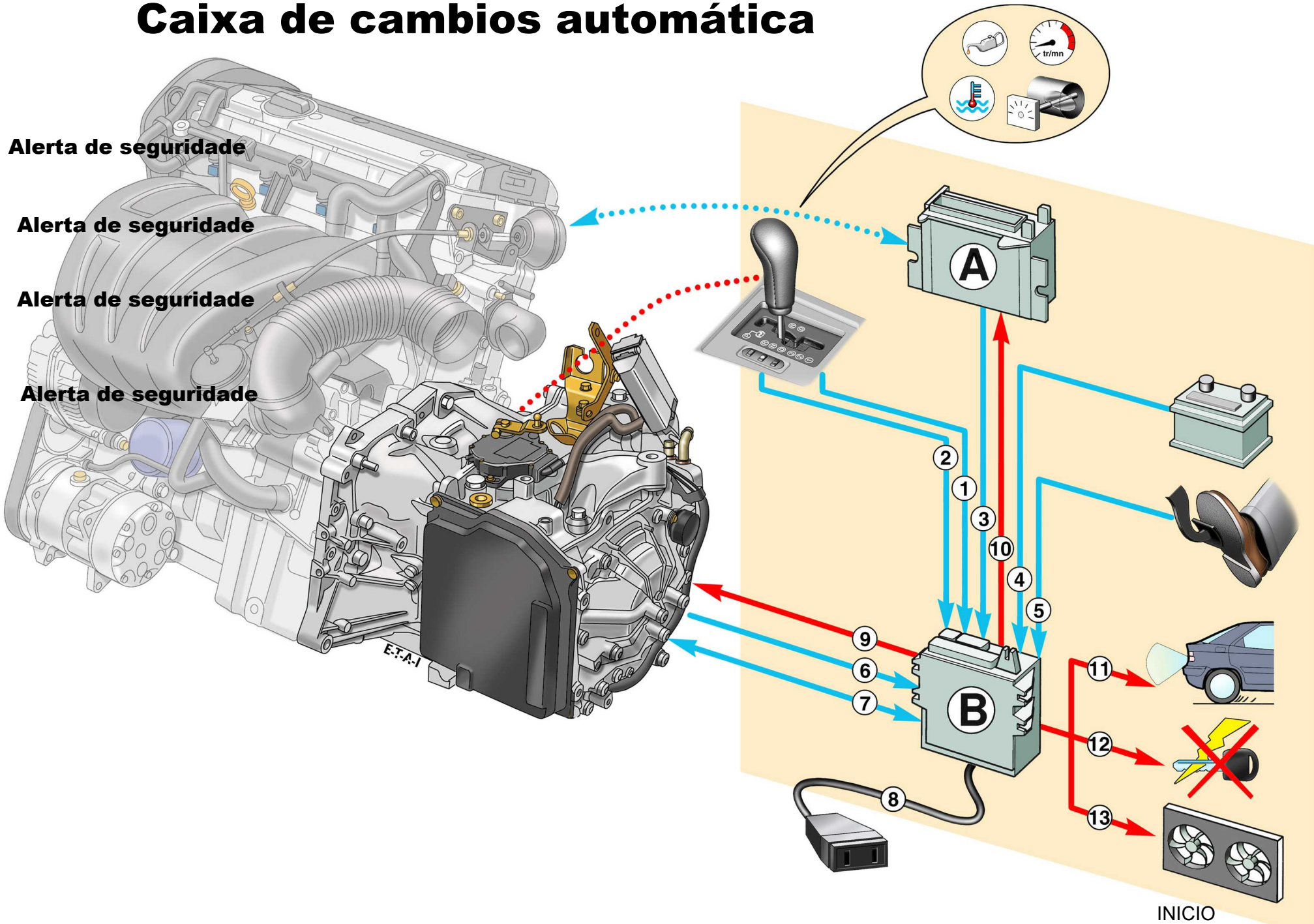

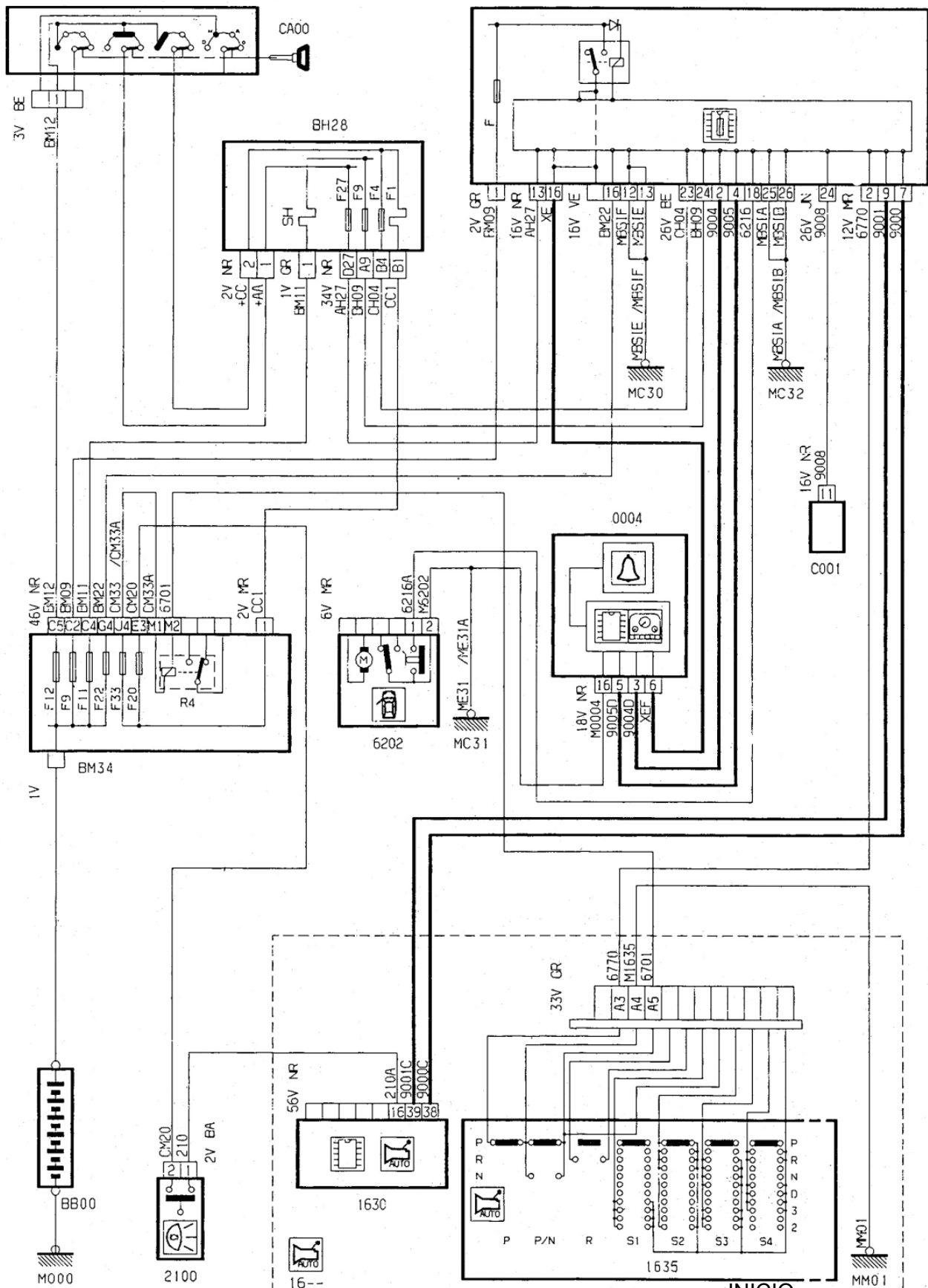

INICIO

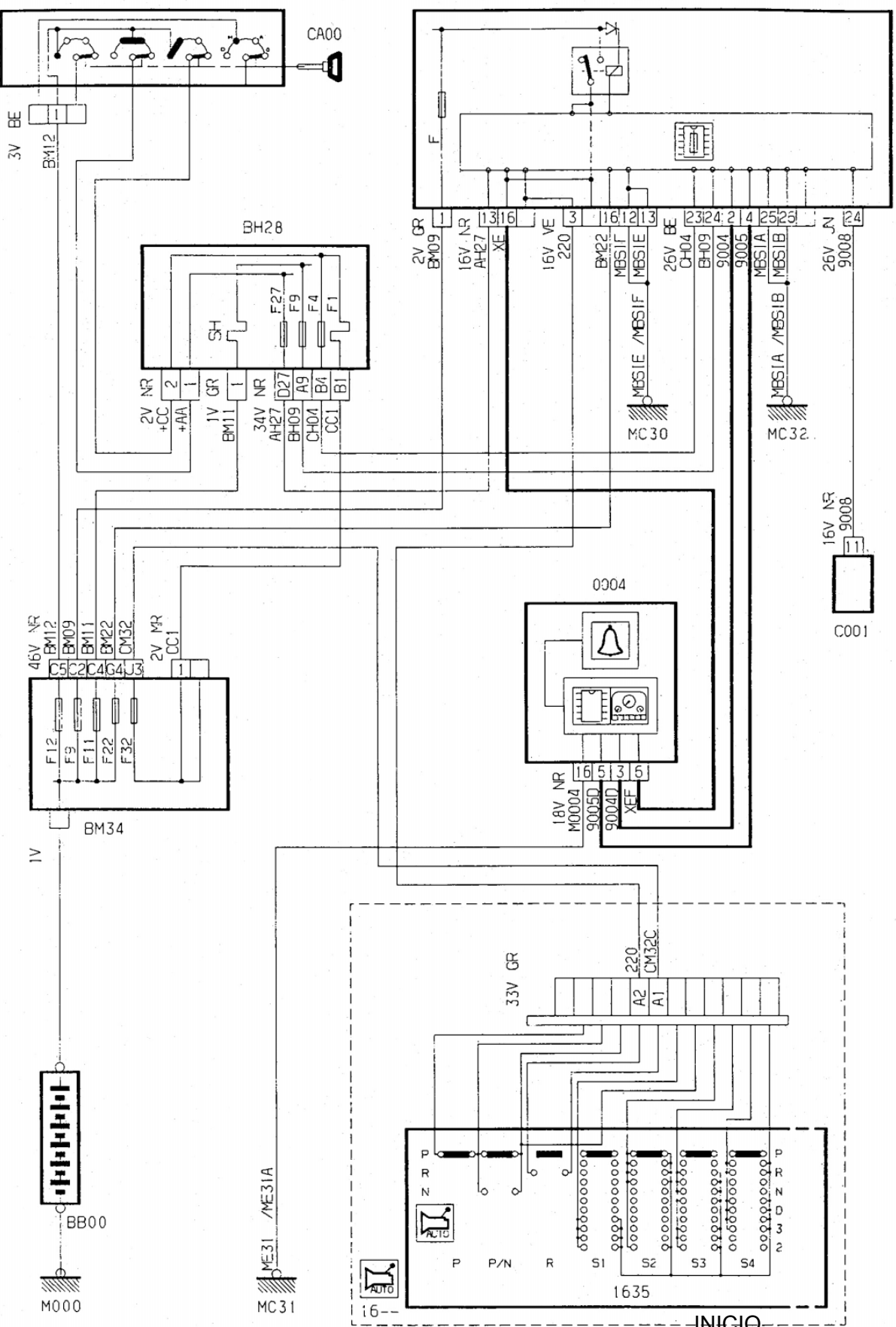

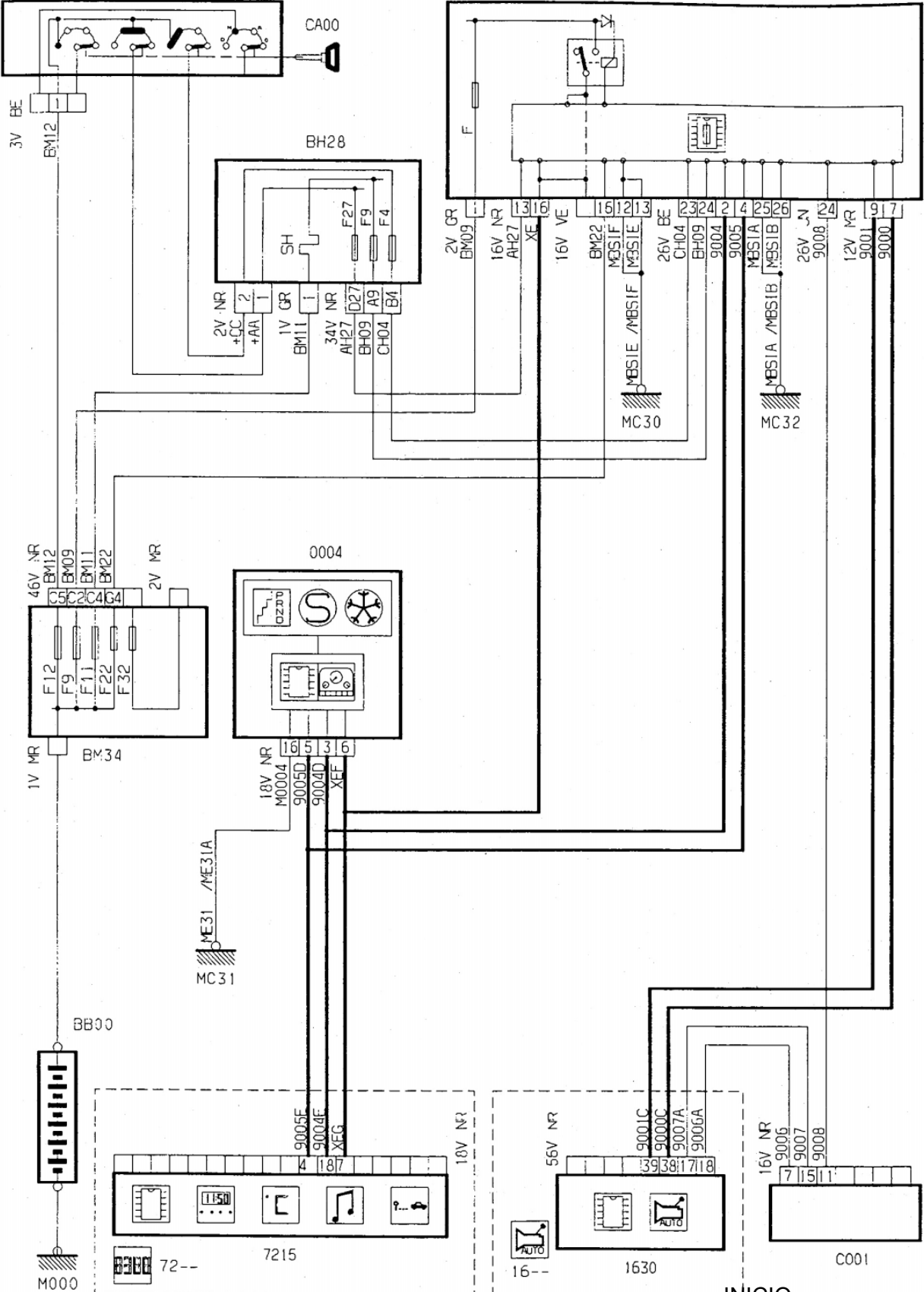

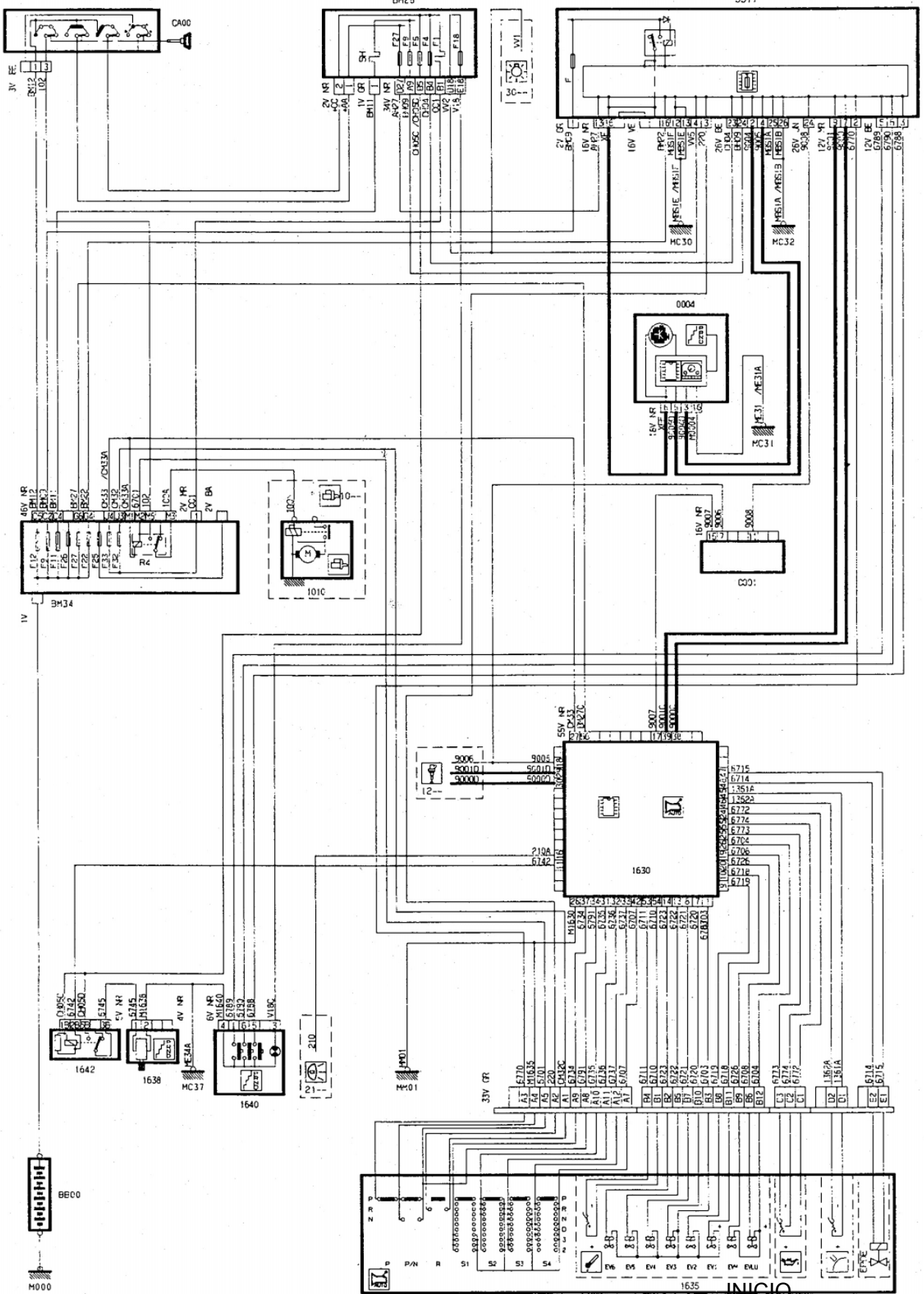

1	6770	1630	6715
2	6771	1630	6714
3	6772	1630	6713
4	6773	1630	6712
5	6774	1630	6711
6	6775	1630	6710
7	6776	1630	6709
8	6777	1630	6708
9	6778	1630	6707
10	6779	1630	6706
11	6780	1630	6705
12	6781	1630	6704
13	6782	1630	6703
14	6783	1630	6702
15	6784	1630	6701
16	6785	1630	6700
17	6786	1630	6699
18	6787	1630	6698
19	6788	1630	6697
20	6789	1630	6696
21	6790	1630	6695
22	6791	1630	6694
23	6792	1630	6693
24	6793	1630	6692
25	6794	1630	6691
26	6795	1630	6690
27	6796	1630	6689
28	6797	1630	6688
29	6798	1630	6687
30	6799	1630	6686
31	6800	1630	6685
32	6801	1630	6684
33	6802	1630	6683
34	6803	1630	6682
35	6804	1630	6681
36	6805	1630	6680
37	6806	1630	6679
38	6807	1630	6678
39	6808	1630	6677
40	6809	1630	6676
41	6810	1630	6675
42	6811	1630	6674
43	6812	1630	6673
44	6813	1630	6672
45	6814	1630	6671
46	6815	1630	6670
47	6816	1630	6669
48	6817	1630	6668
49	6818	1630	6667
50	6819	1630	6666
51	6820	1630	6665
52	6821	1630	6664
53	6822	1630	6663
54	6823	1630	6662
55	6824	1630	6661
56	6825	1630	6660
57	6826	1630	6659
58	6827	1630	6658
59	6828	1630	6657
60	6829	1630	6656
61	6830	1630	6655
62	6831	1630	6654
63	6832	1630	6653
64	6833	1630	6652
65	6834	1630	6651
66	6835	1630	6650
67	6836	1630	6649
68	6837	1630	6648
69	6838	1630	6647
70	6839	1630	6646
71	6840	1630	6645
72	6841	1630	6644
73	6842	1630	6643
74	6843	1630	6642
75	6844	1630	6641
76	6845	1630	6640
77	6846	1630	6639
78	6847	1630	6638
79	6848	1630	6637
80	6849	1630	6636
81	6850	1630	6635
82	6851	1630	6634
83	6852	1630	6633
84	6853	1630	6632
85	6854	1630	6631
86	6855	1630	6630
87	6856	1630	6629
88	6857	1630	6628
89	6858	1630	6627
90	6859	1630	6626
91	6860	1630	6625
92	6861	1630	6624
93	6862	1630	6623
94	6863	1630	6622
95	6864	1630	6621
96	6865	1630	6620
97	6866	1630	6619
98	6867	1630	6618
99	6868	1630	6617
100	6869	1630	6616

INICIO

Axuda a conducción

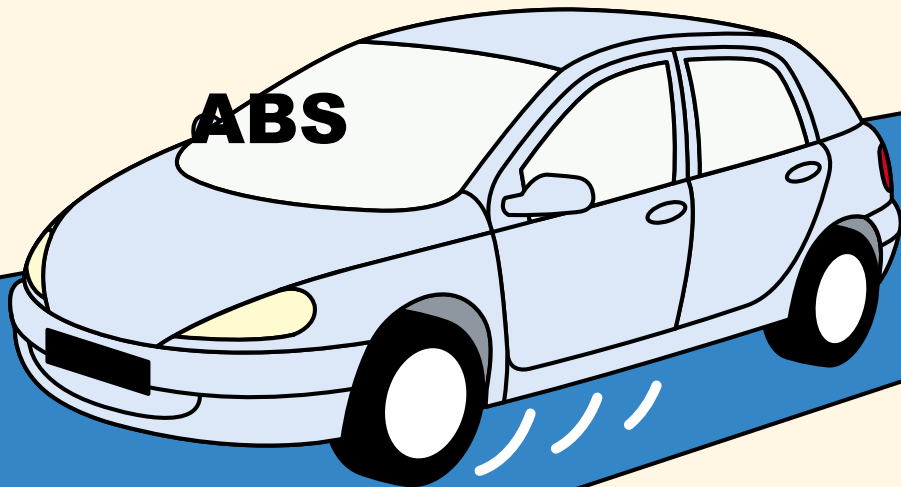

INICIO

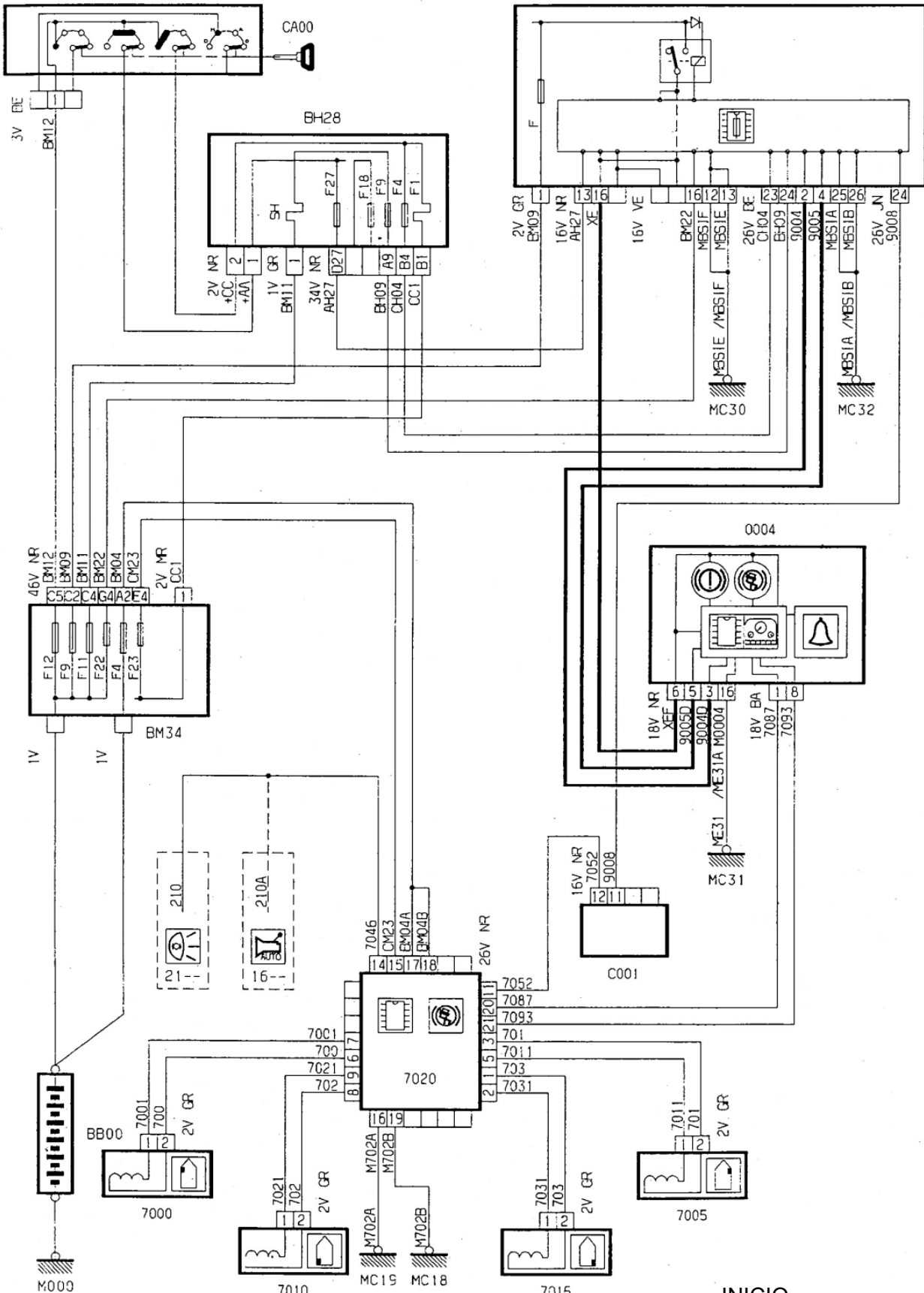

Iluminación exterior

3 Portas

5 Portas

Break

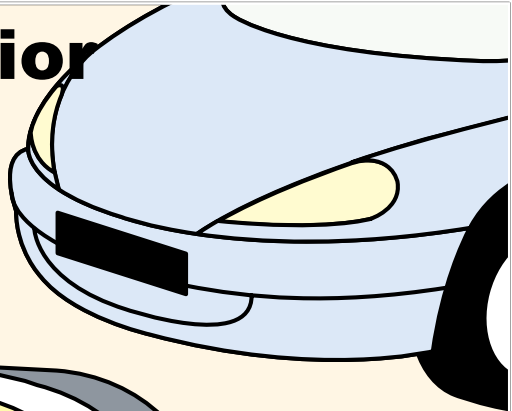
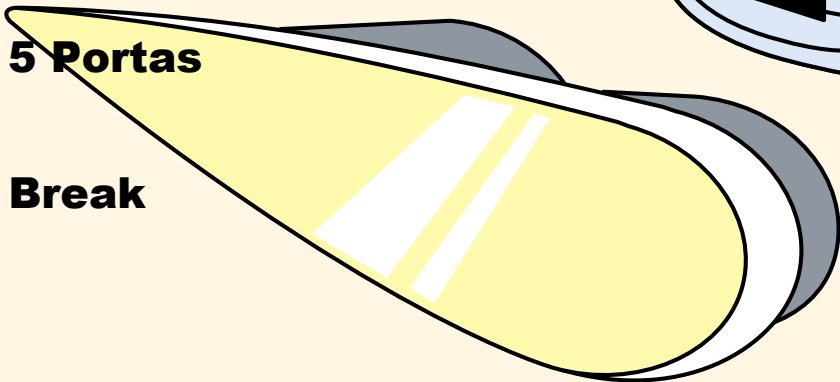

INICIO

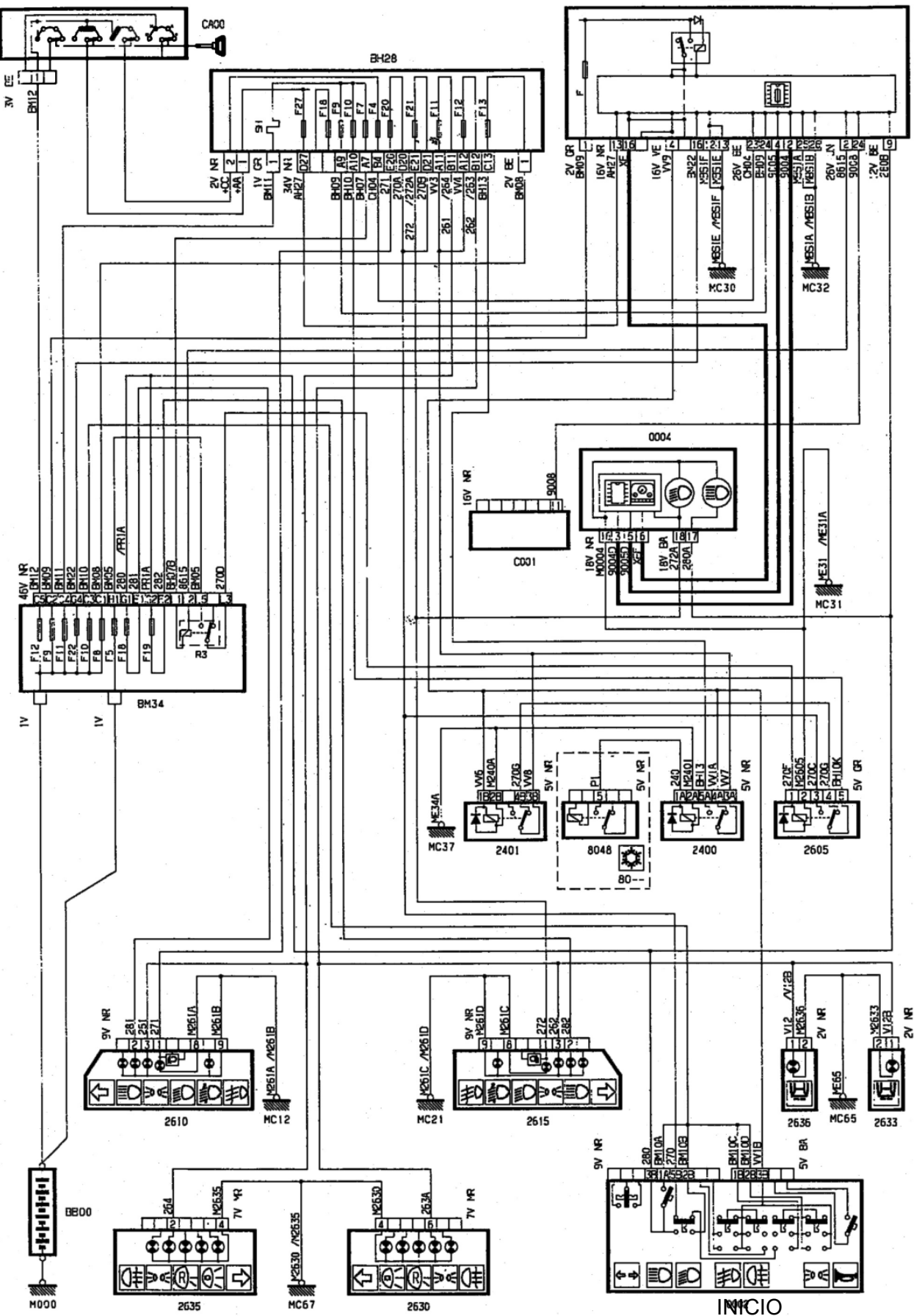

Iluminación interior

3 portas

5 Portas

Break

INICIO



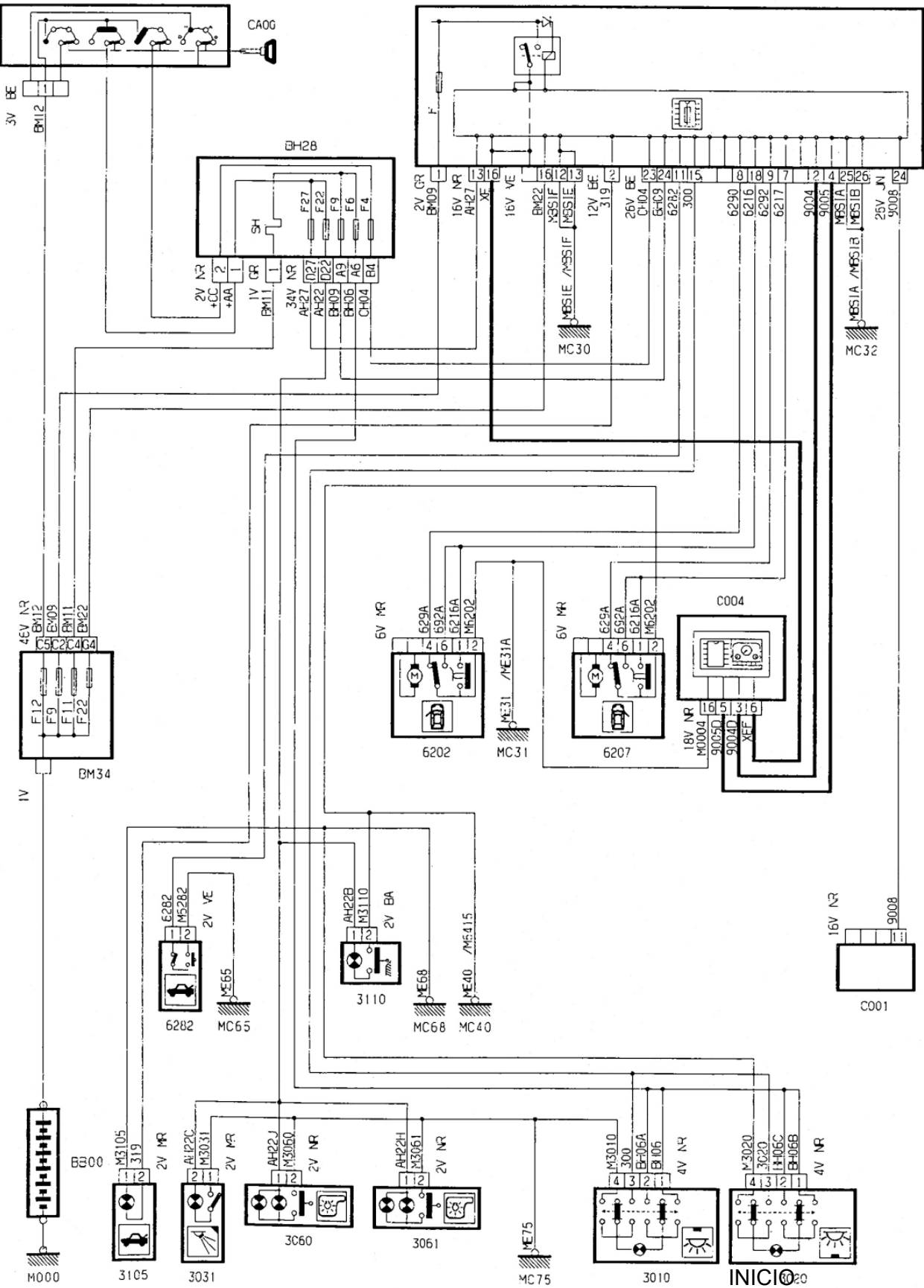

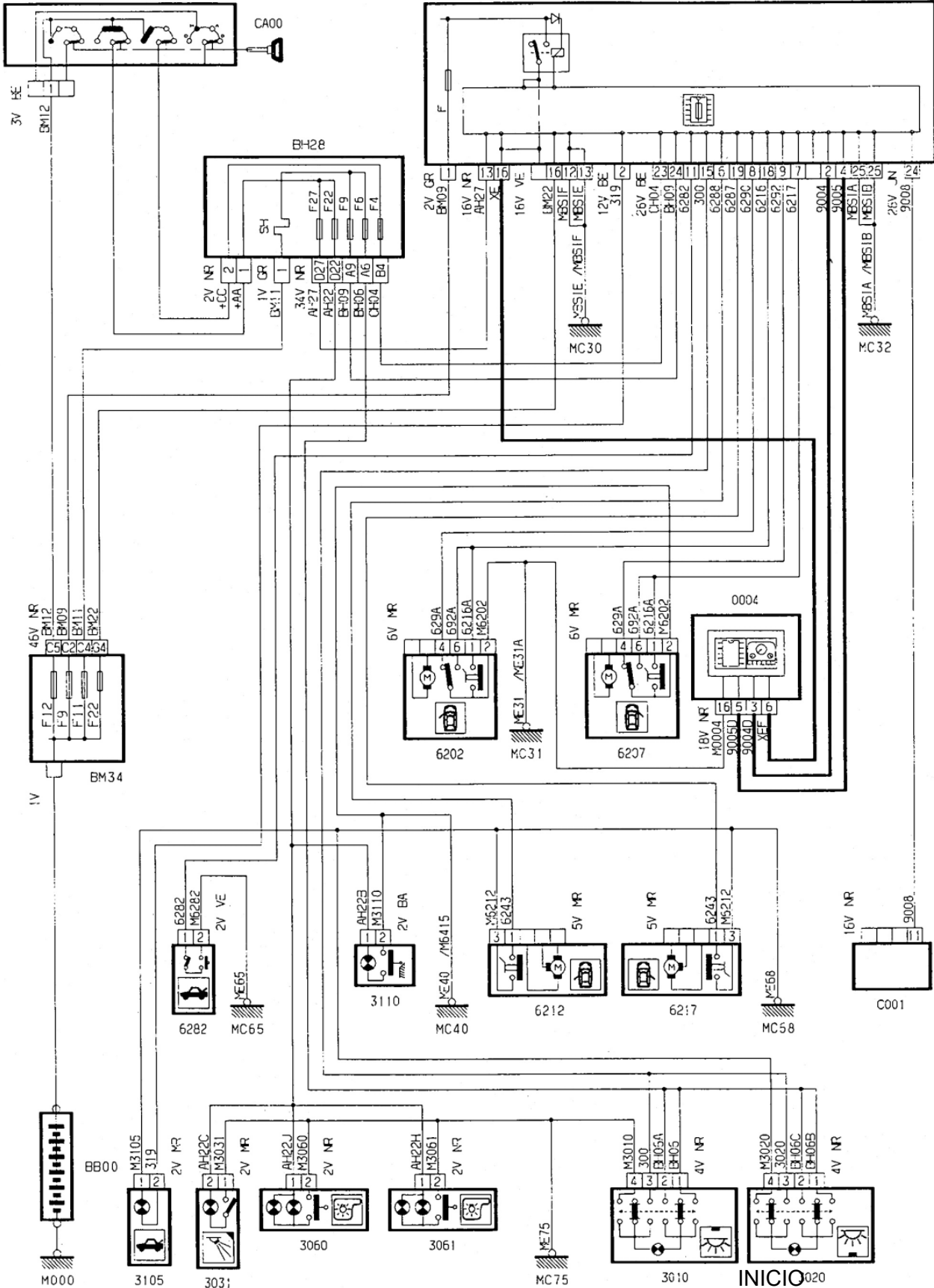

Luces de stop

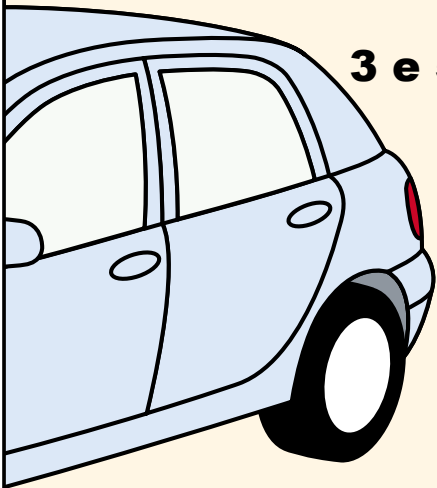

3 e 5 Portas

Break

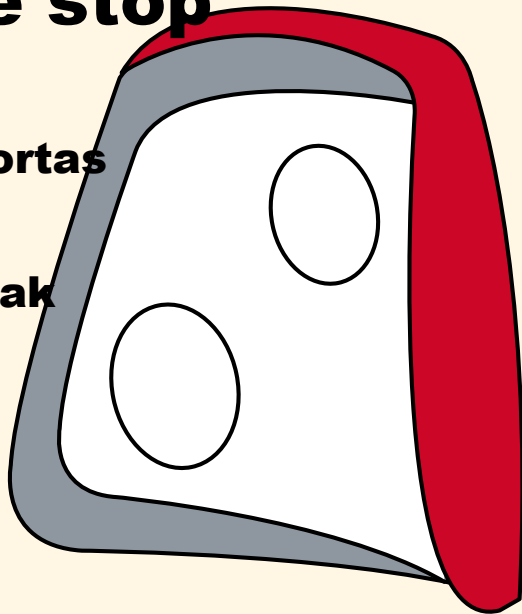

INICIO

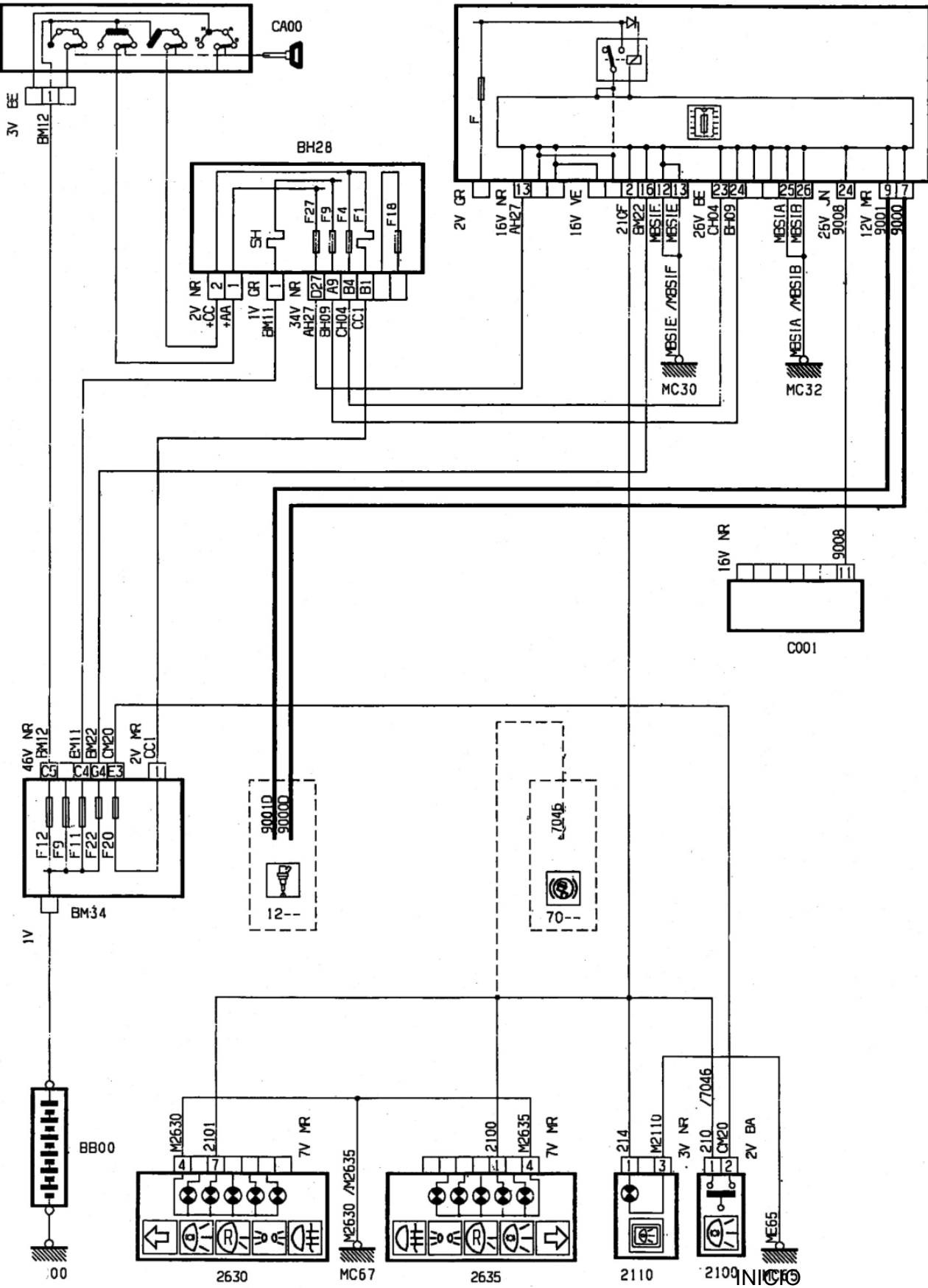

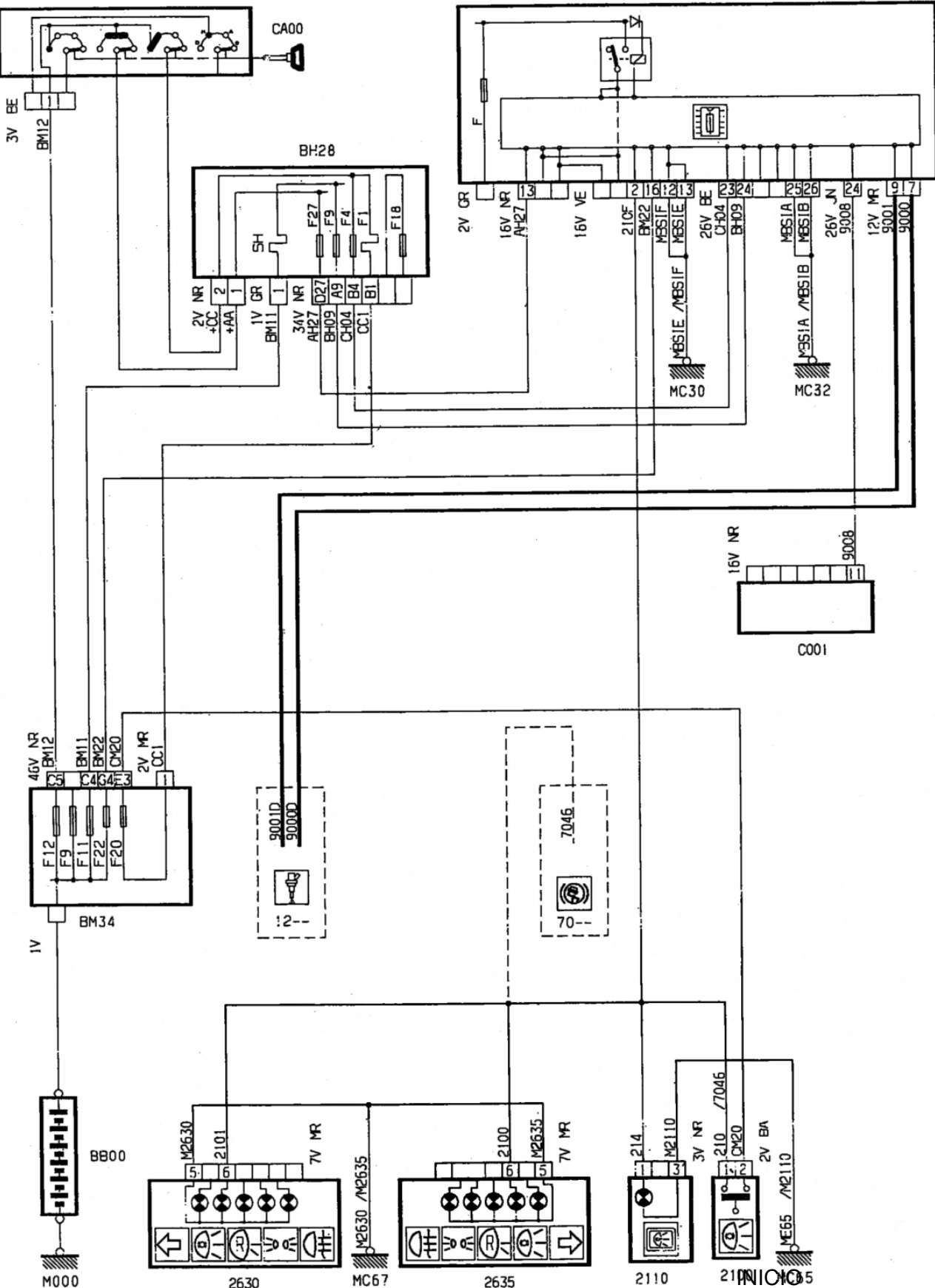

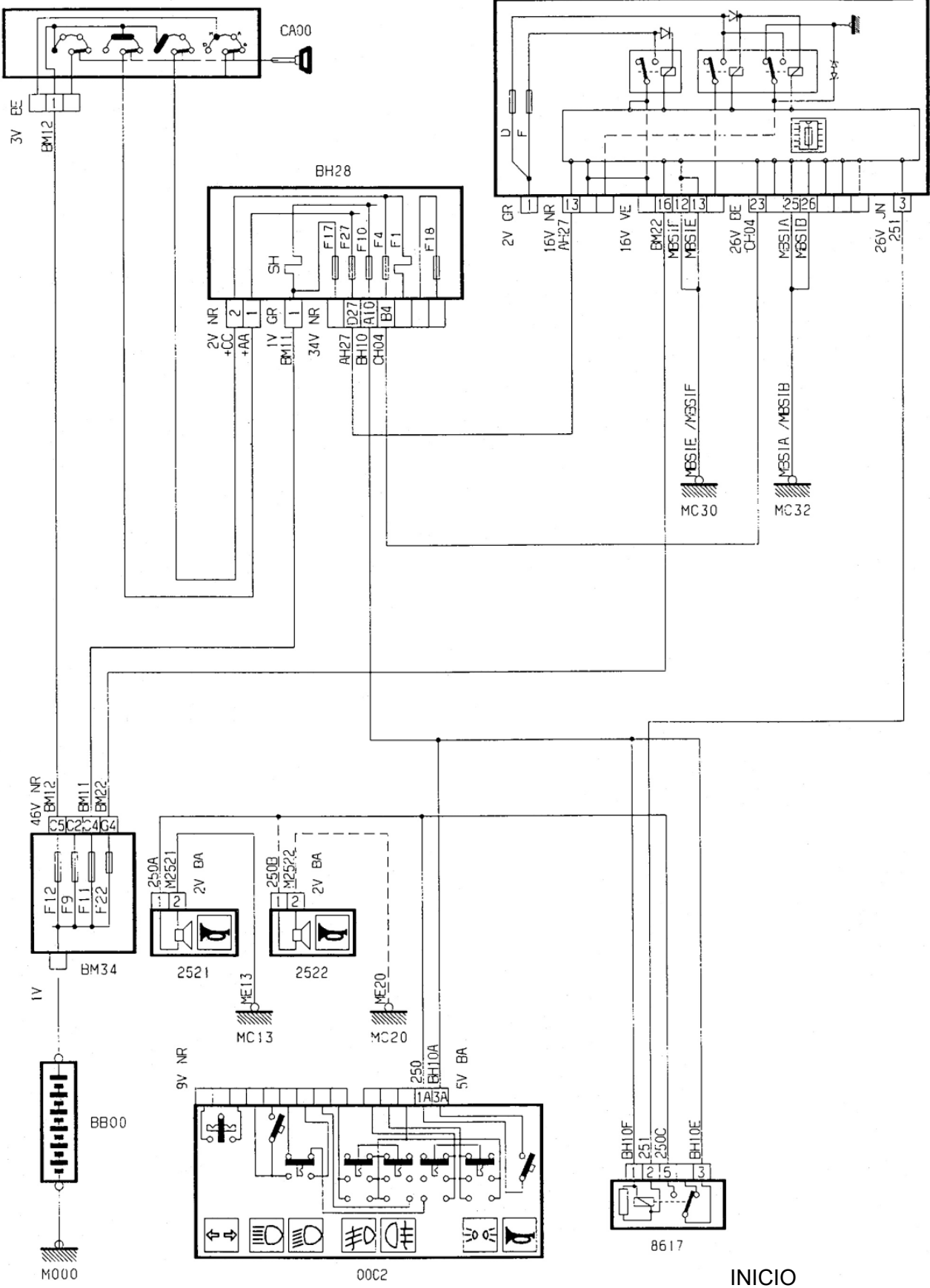

Cadro de instrumentos



Testigo presencia auga en gasoil

Testigo t^a motor

Testigo nivel presión aceite

Testigo nivel combustible

Testigo líquido freos e freo de man

Testigo pastillas

Testigo presencia
agua en gasoil

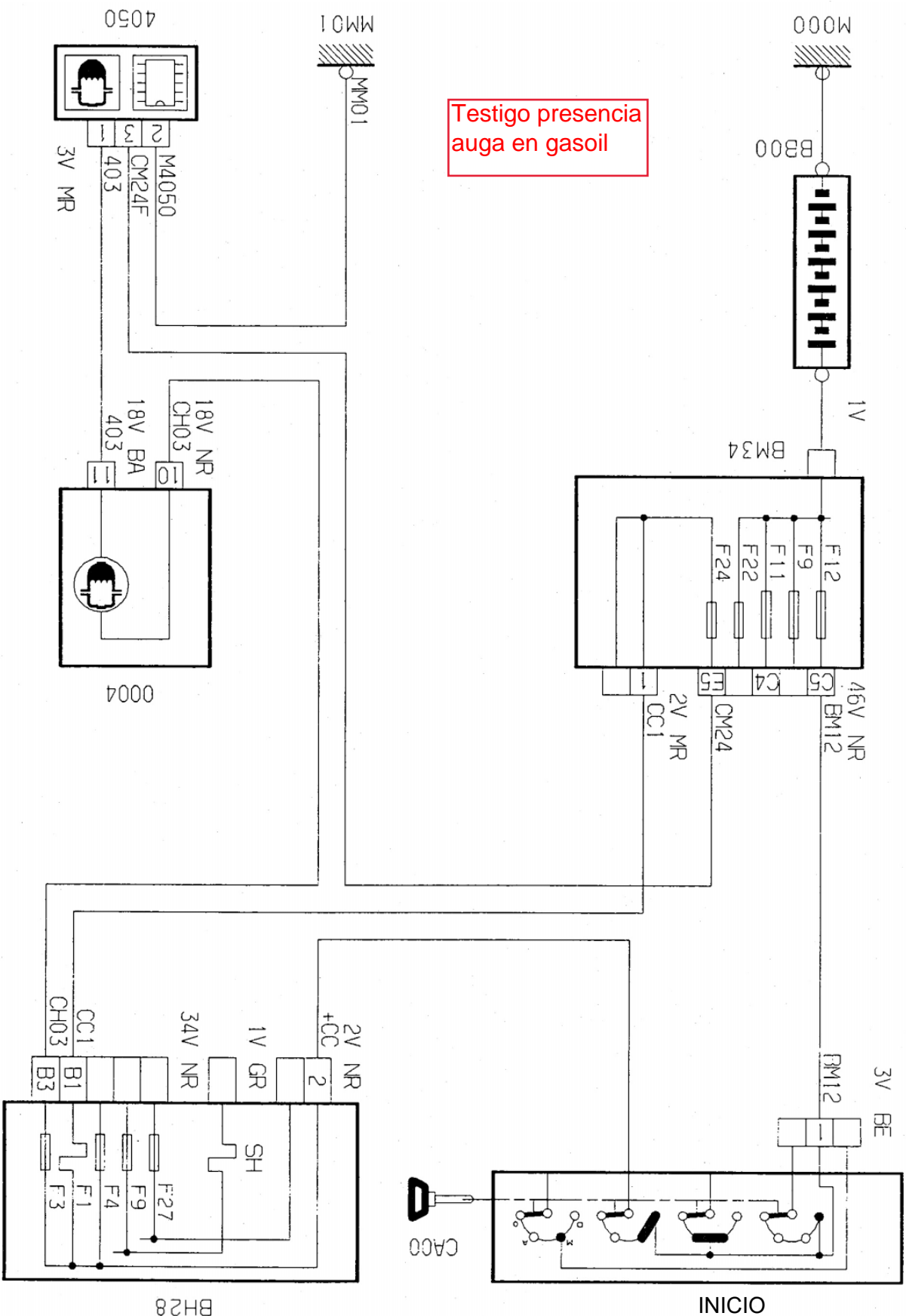

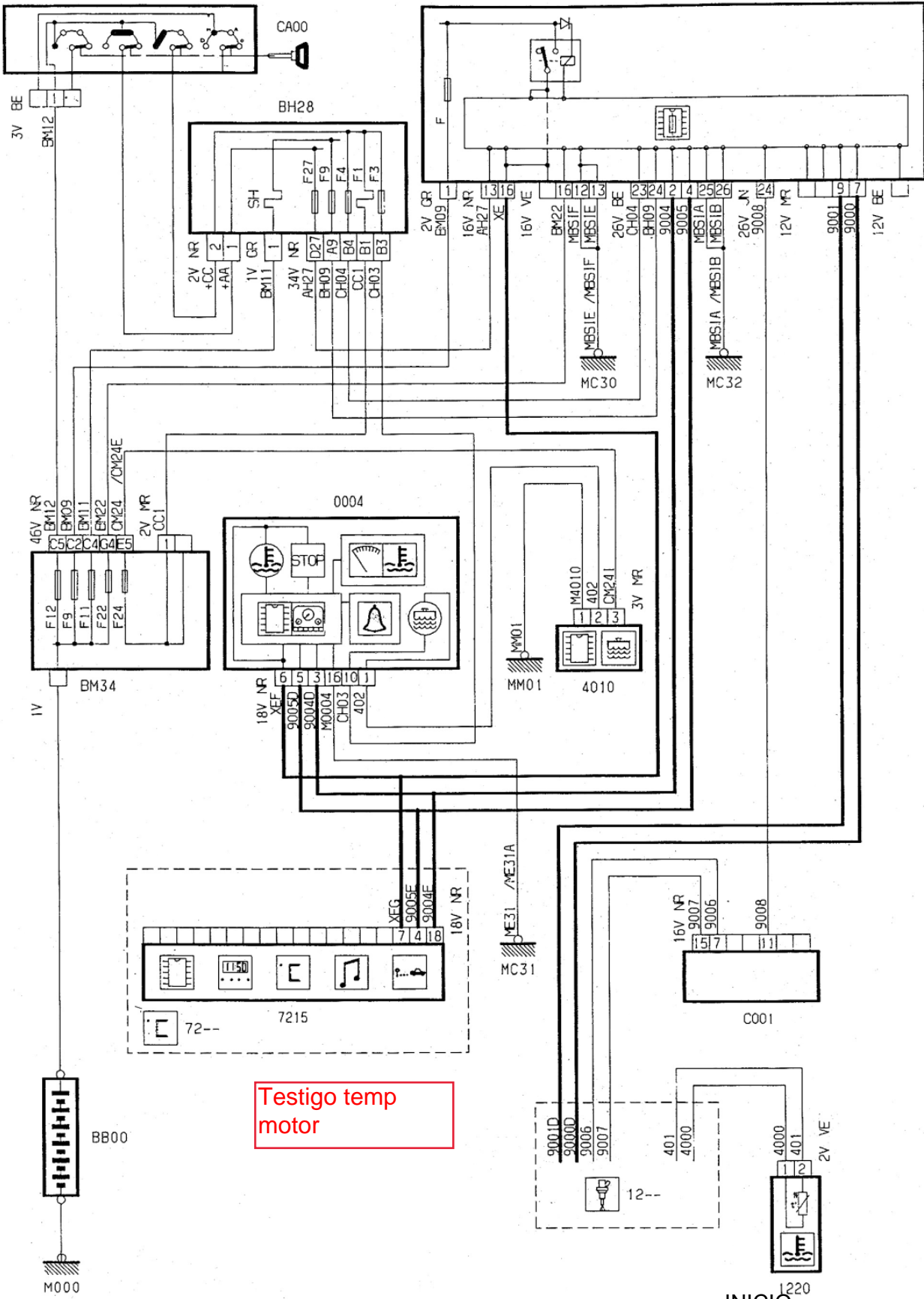

Testigo temp motor

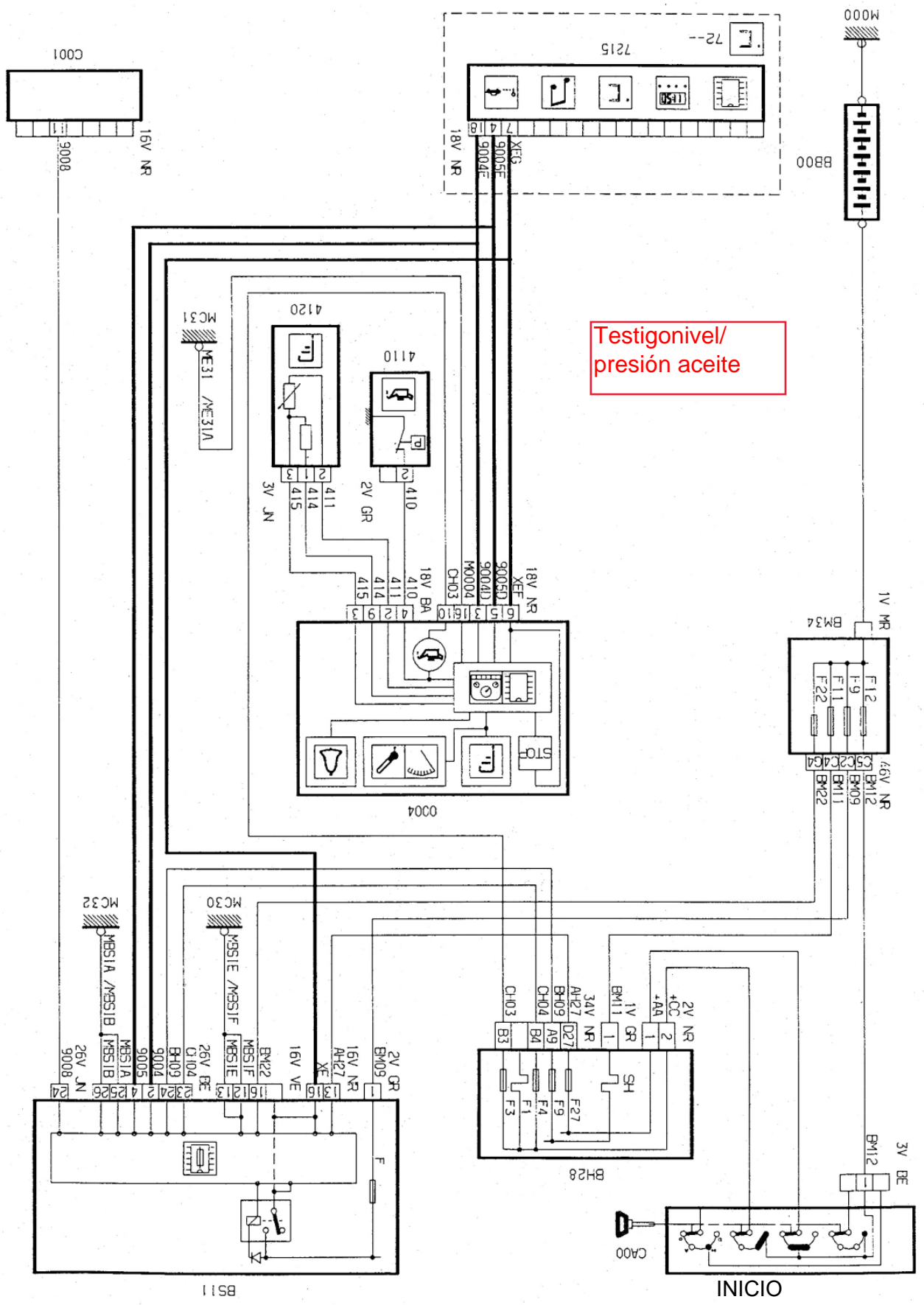

Testigonivel/
presión aceite

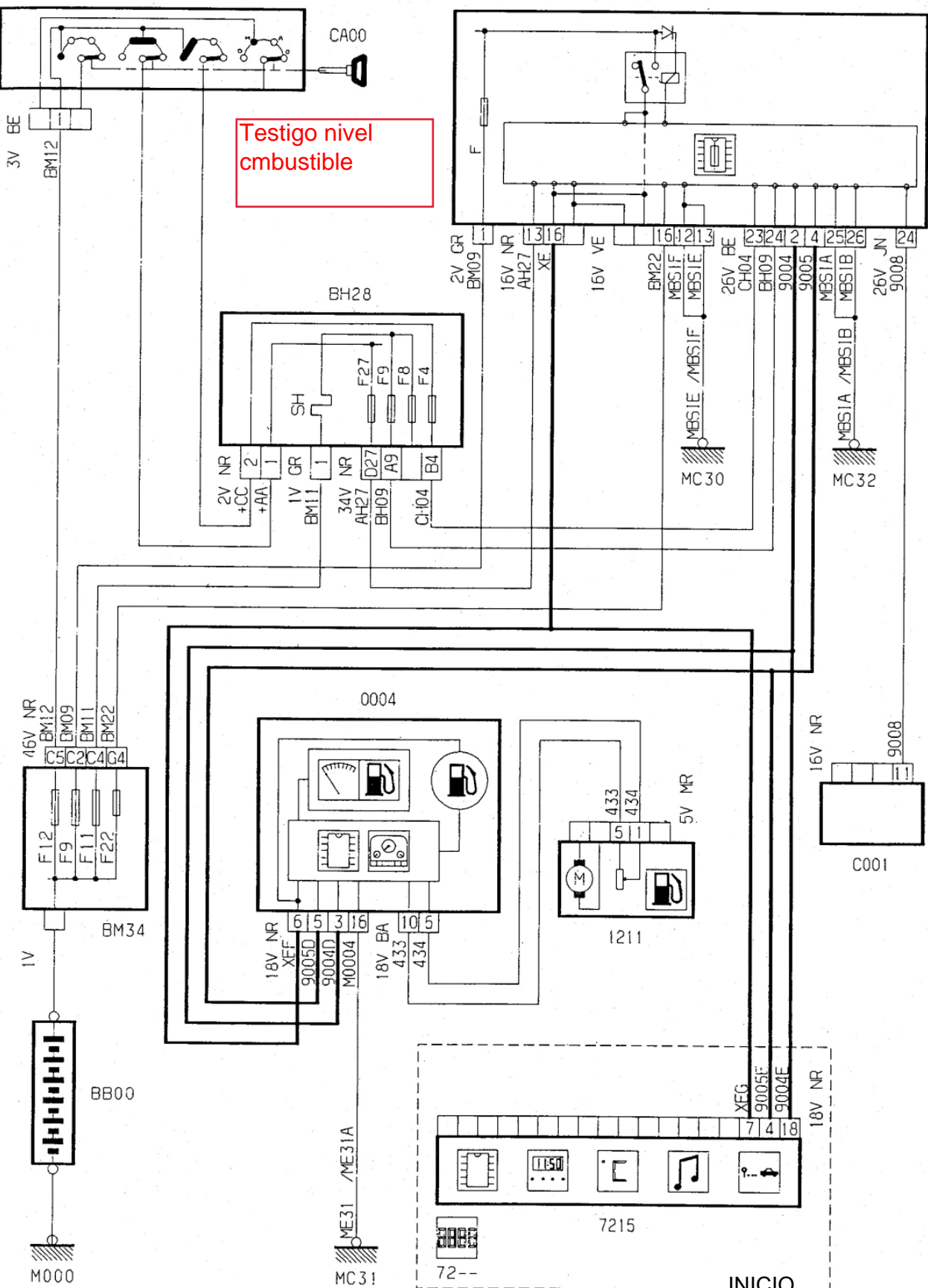

Testigo nivel combustible

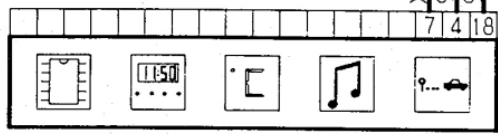
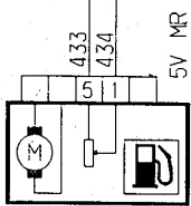
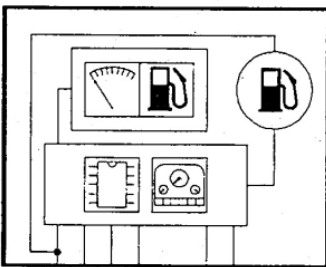
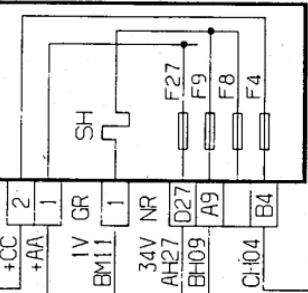

INICIO

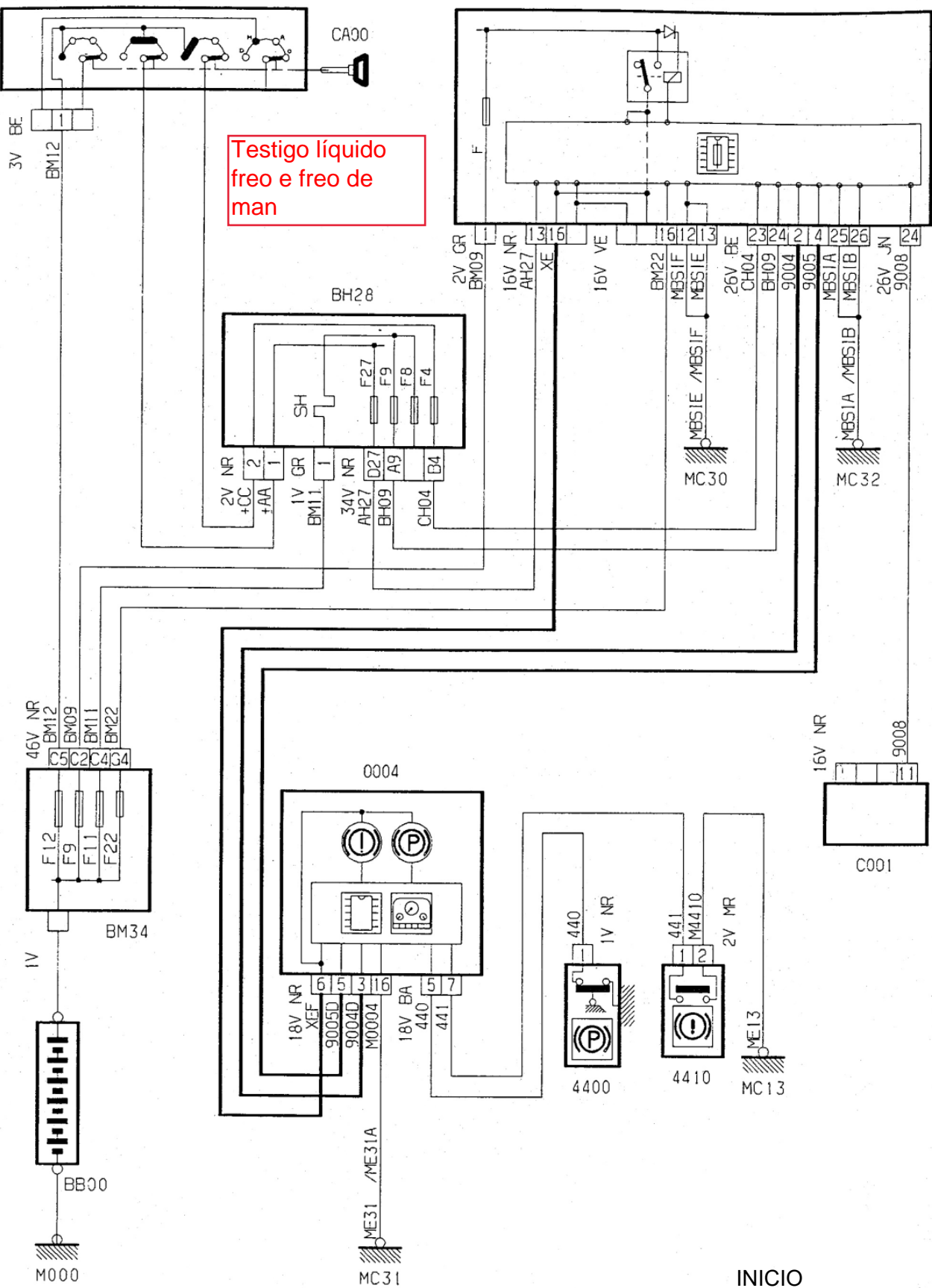

Testigo líquido
freo e freo de
man

BH28

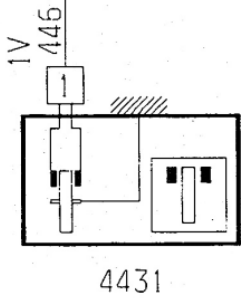
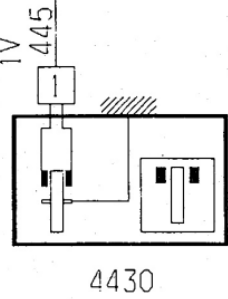
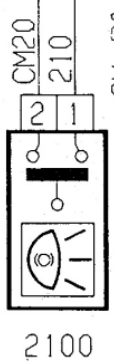
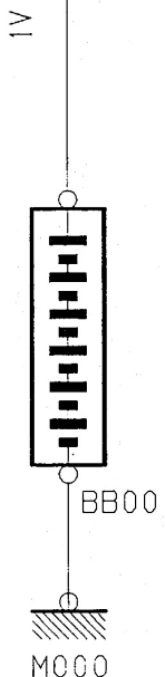
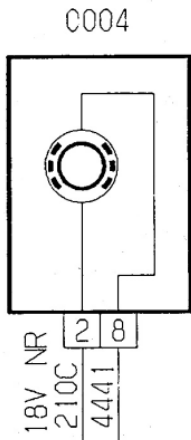
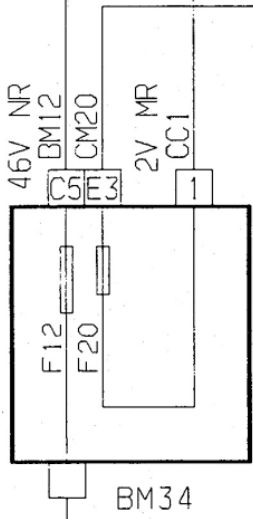
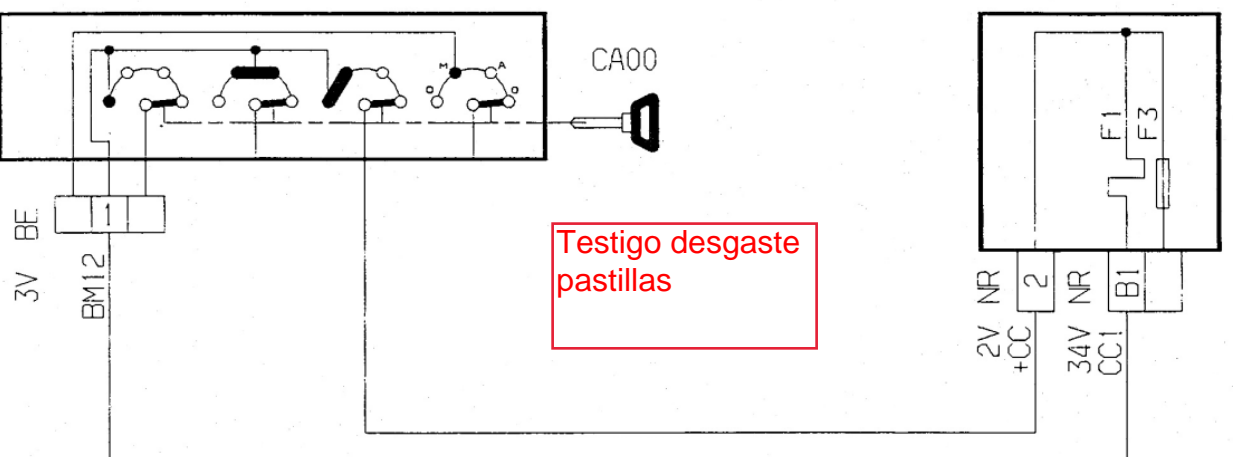

INICIO

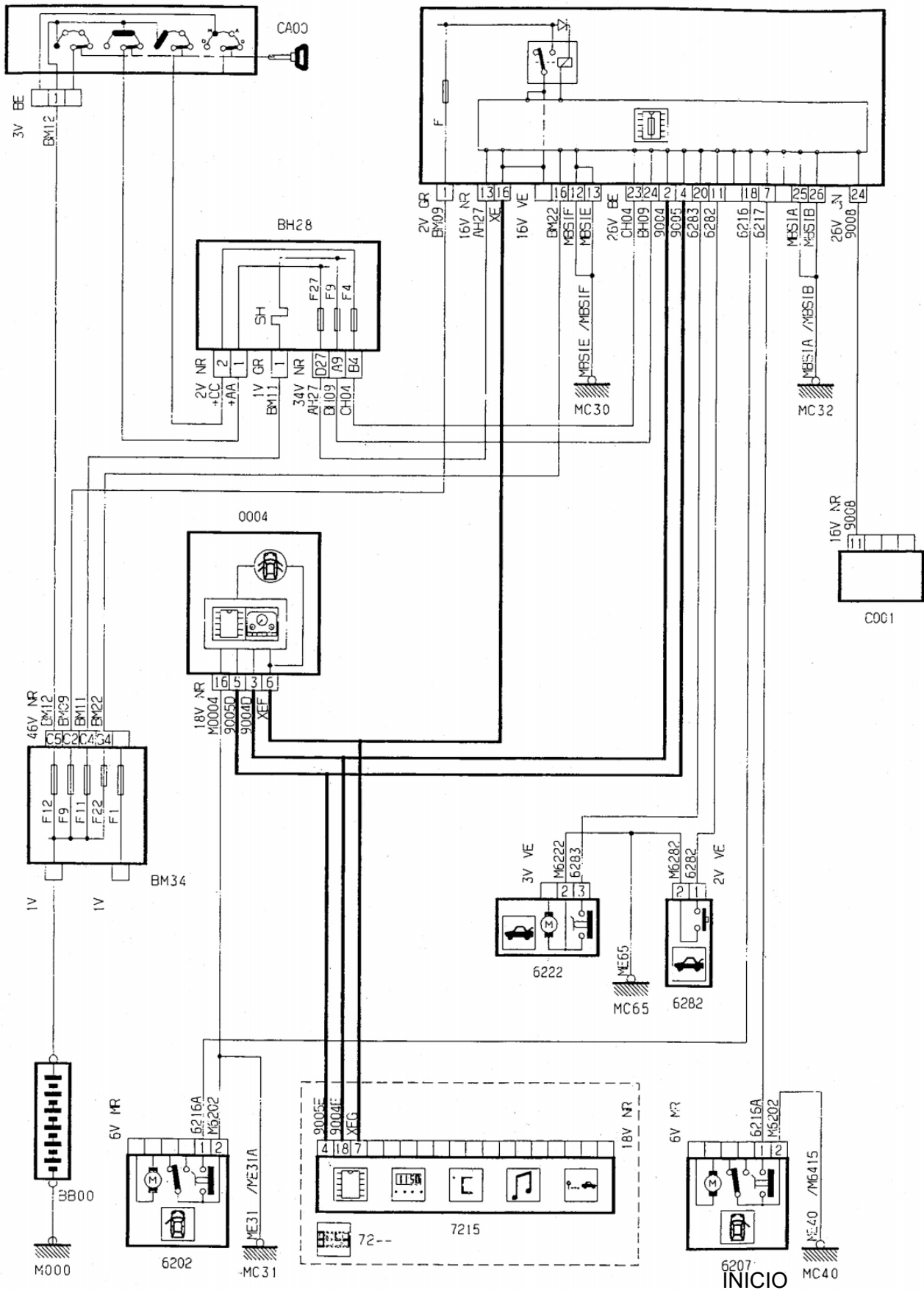

INICIO

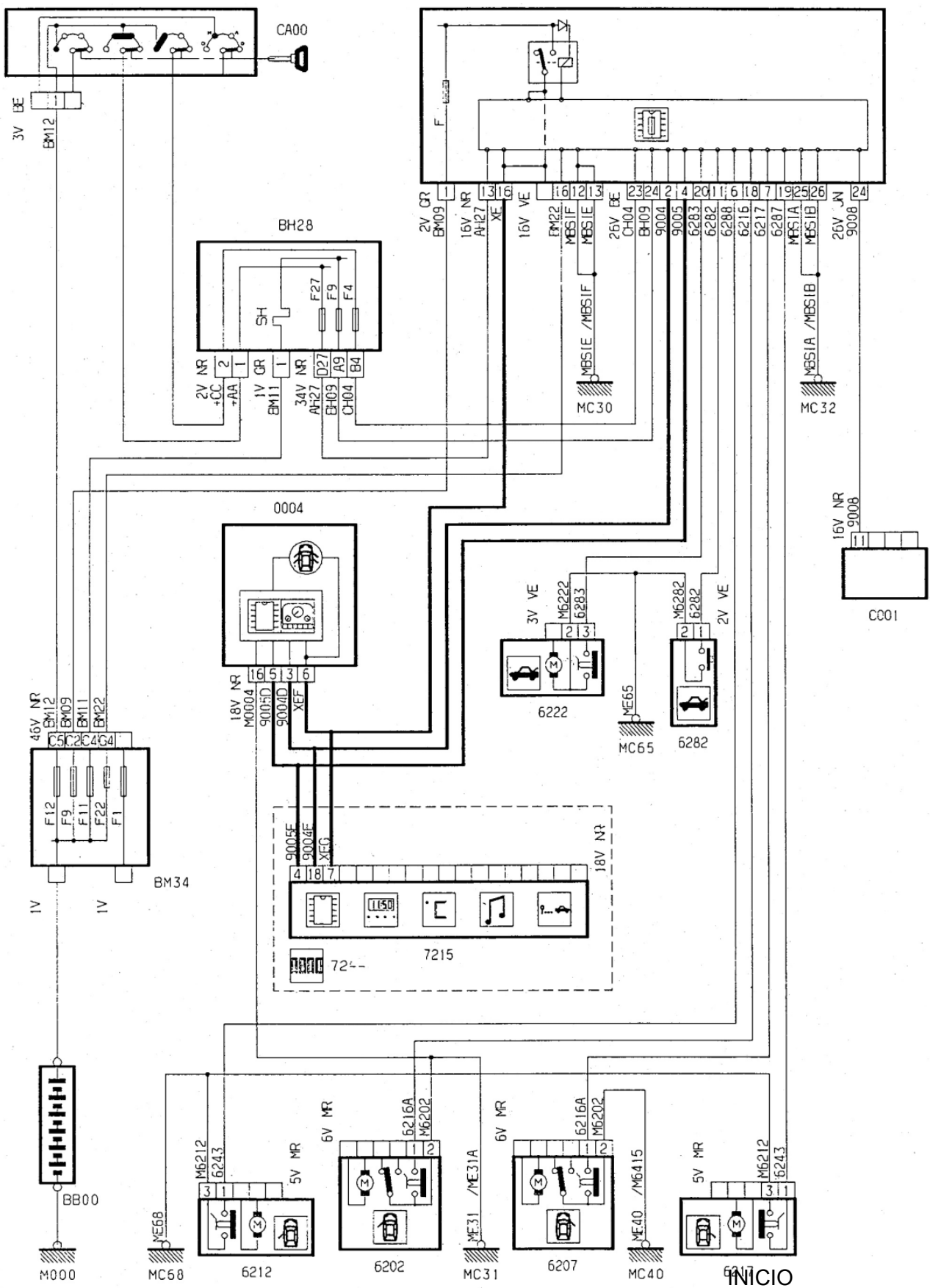

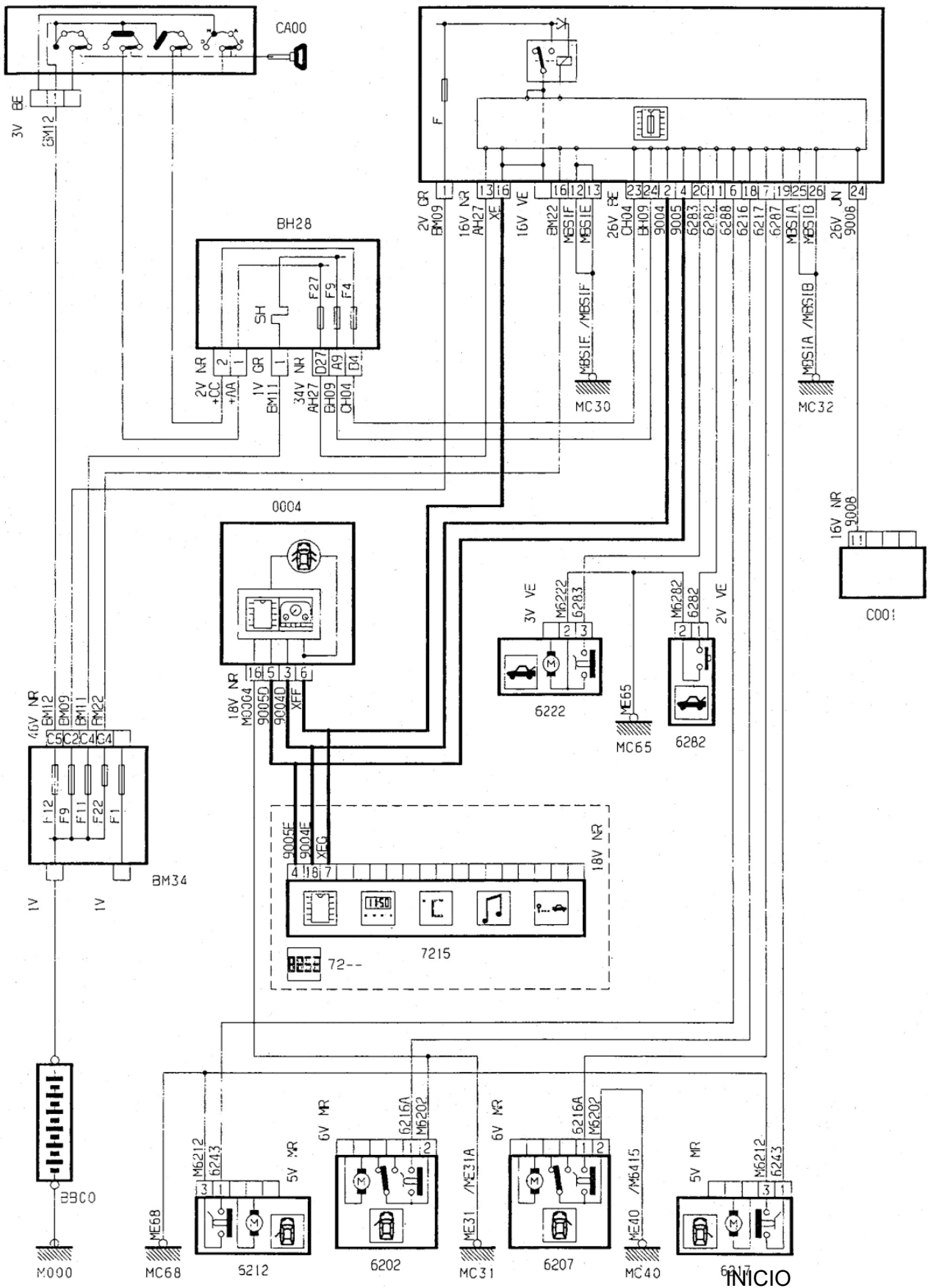

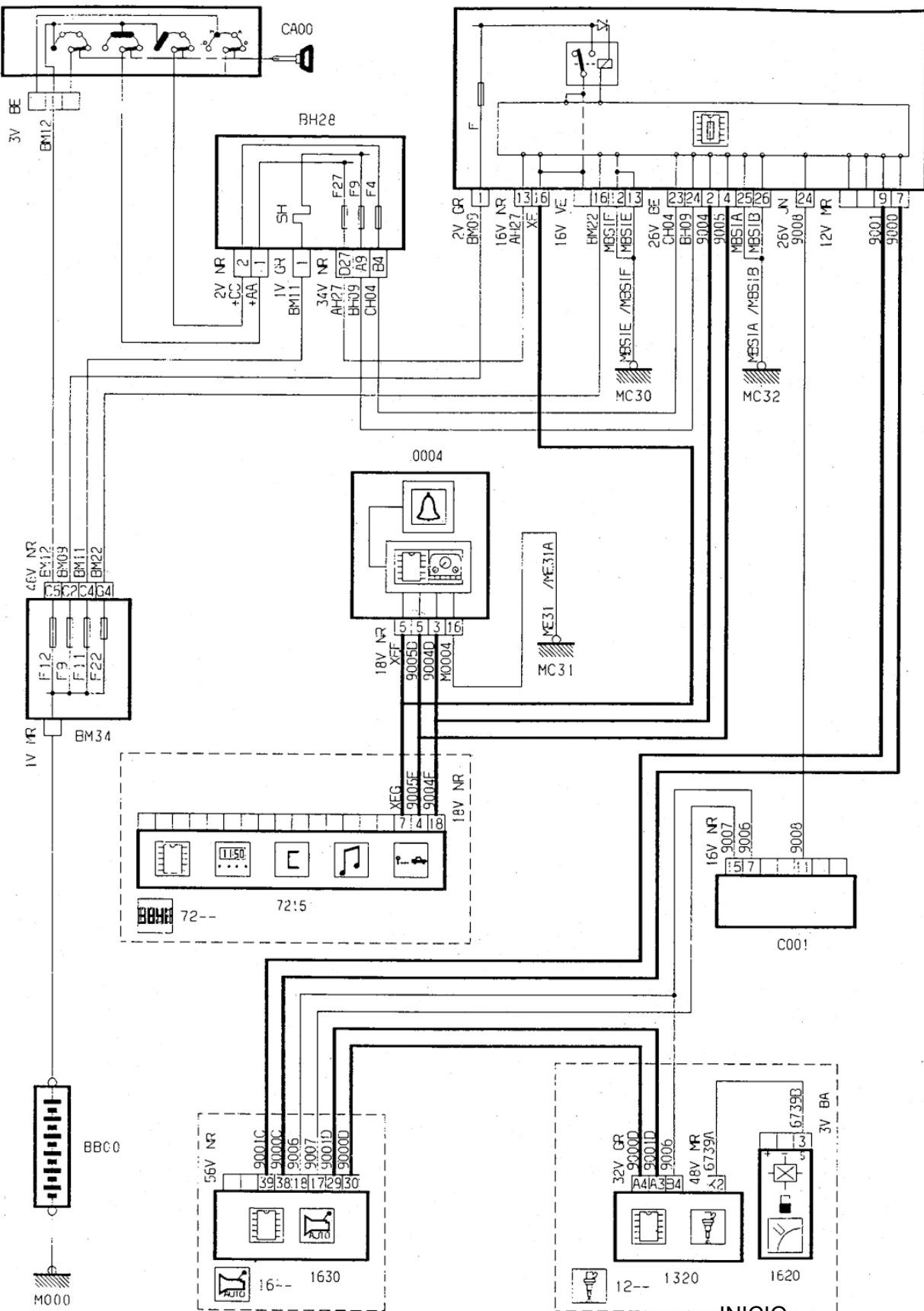

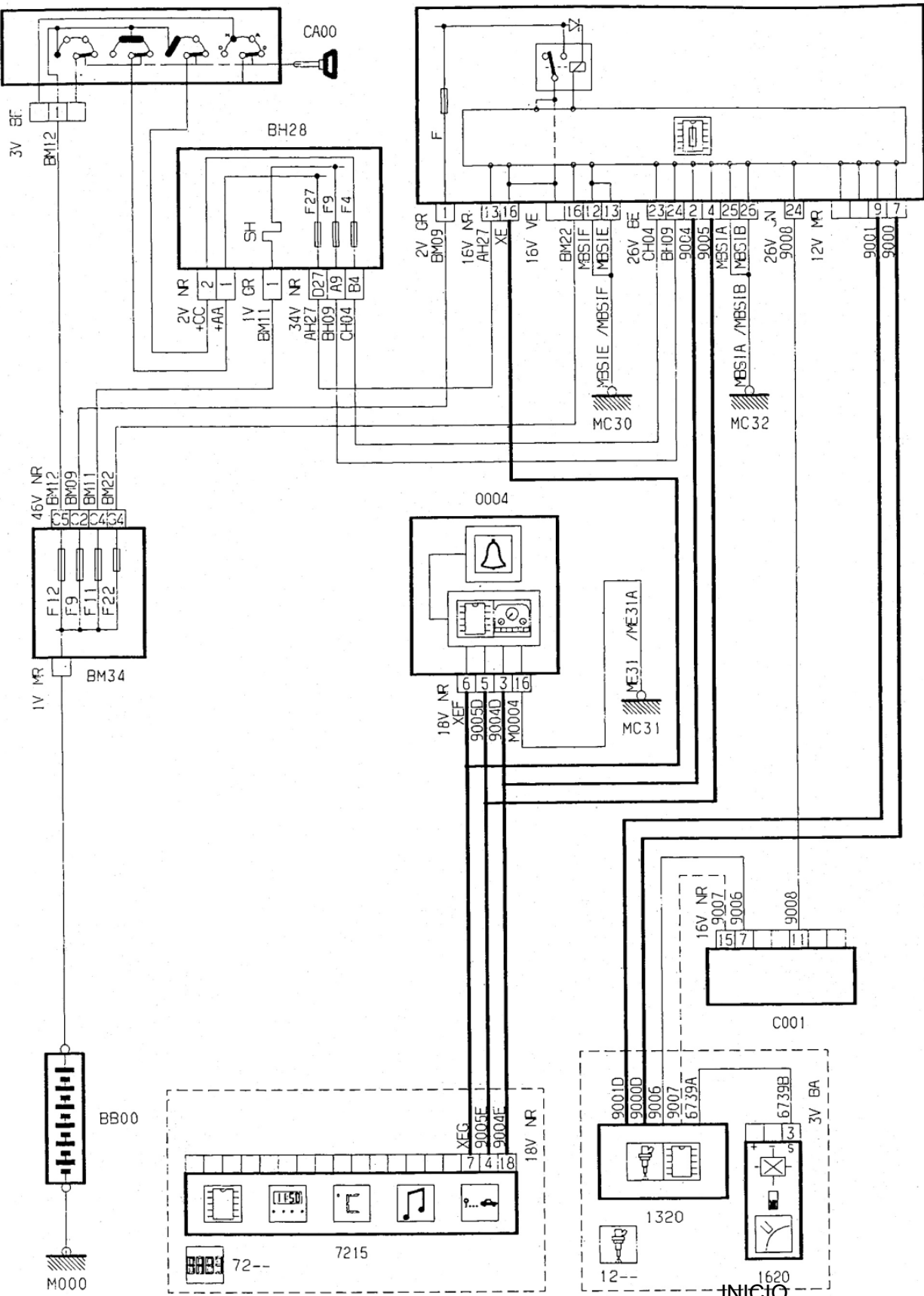

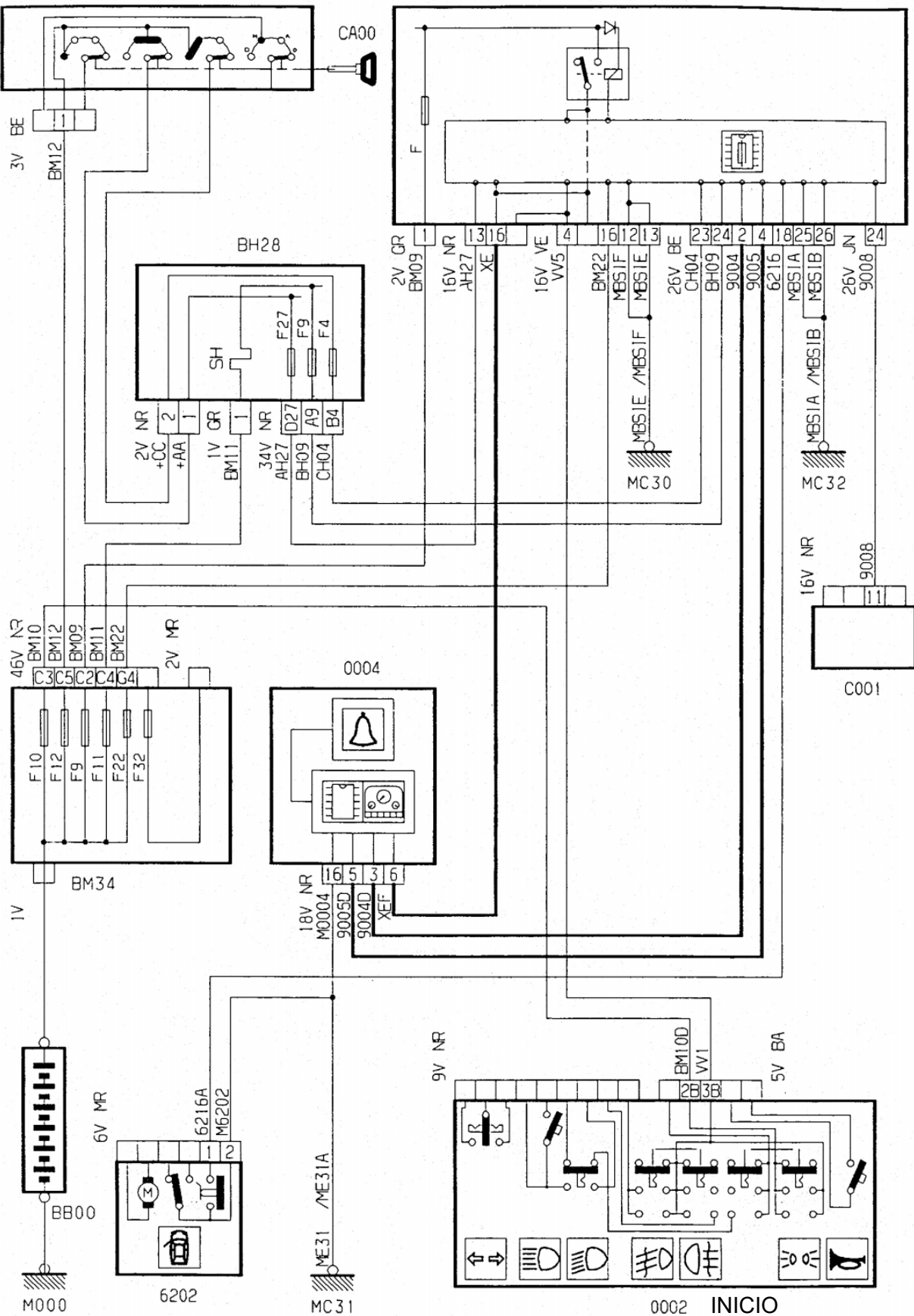

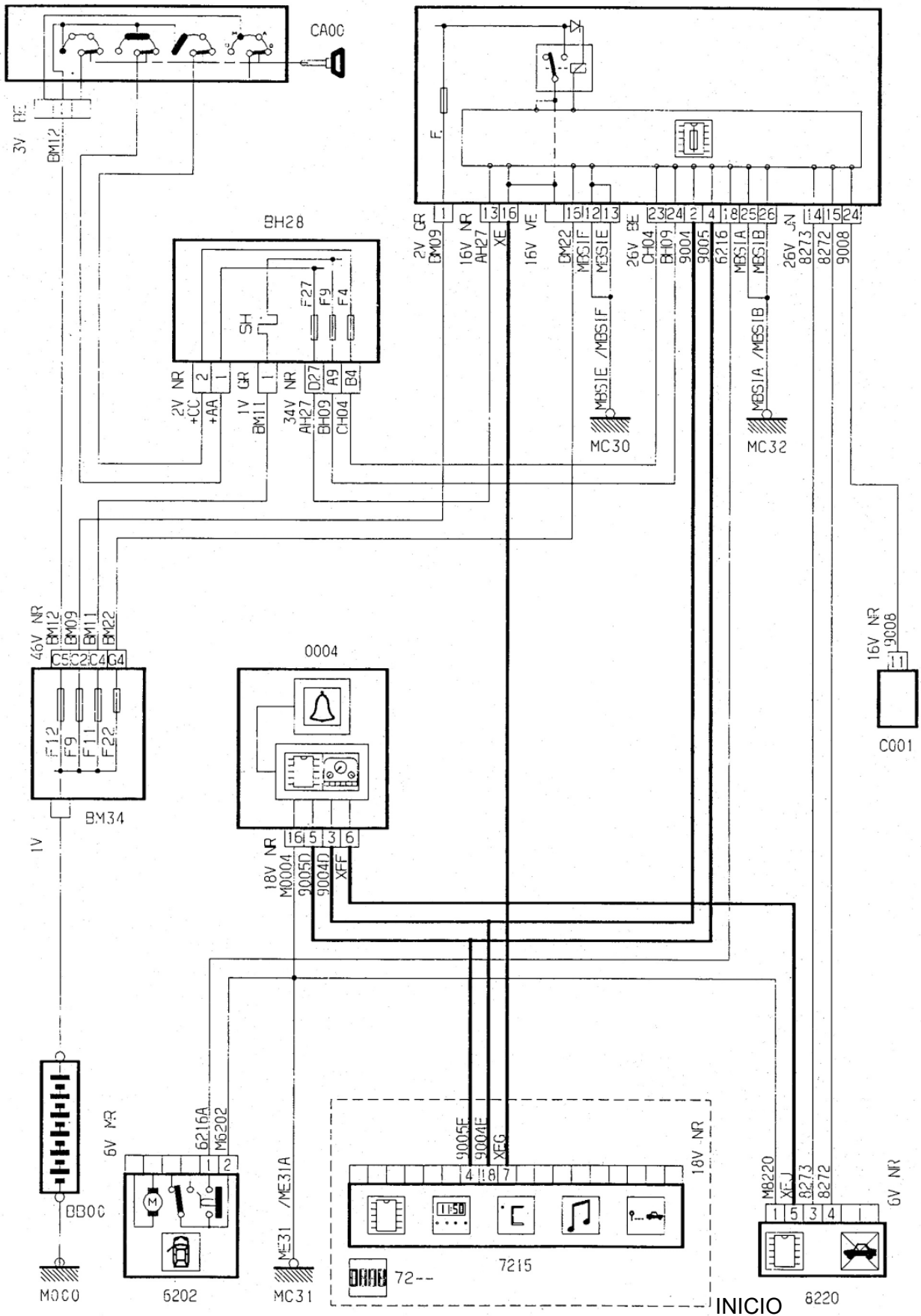

BH28

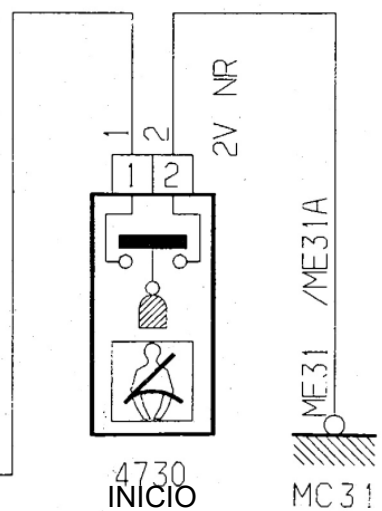
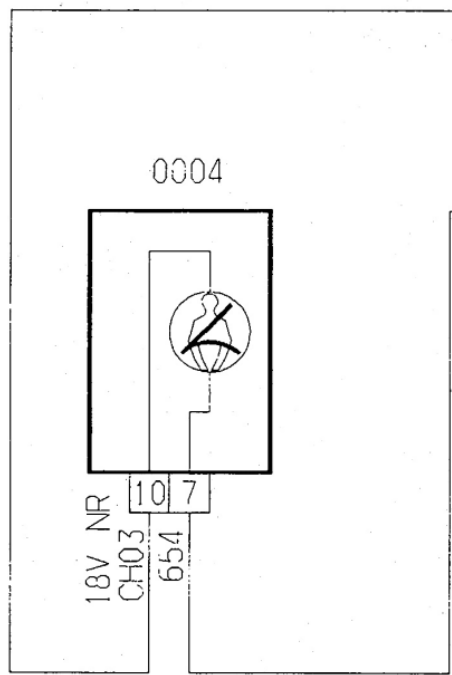
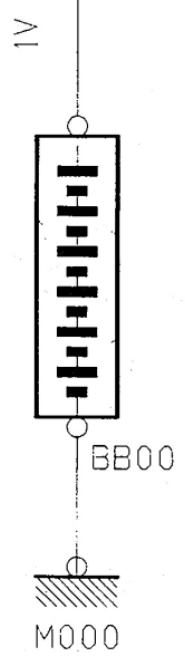
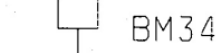
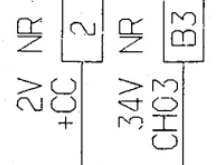
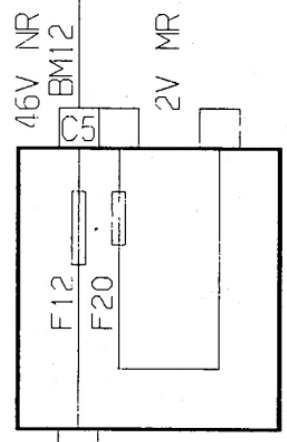
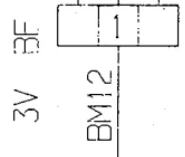
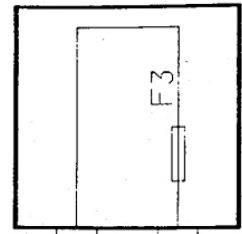
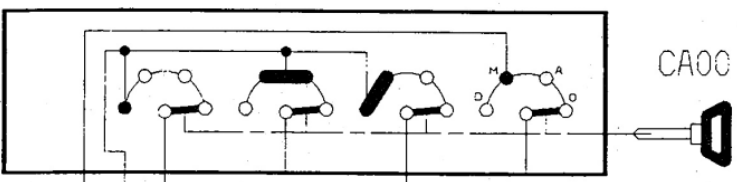

Axuda estacionamento

3 Portas

5 Portas

Break



INICIO

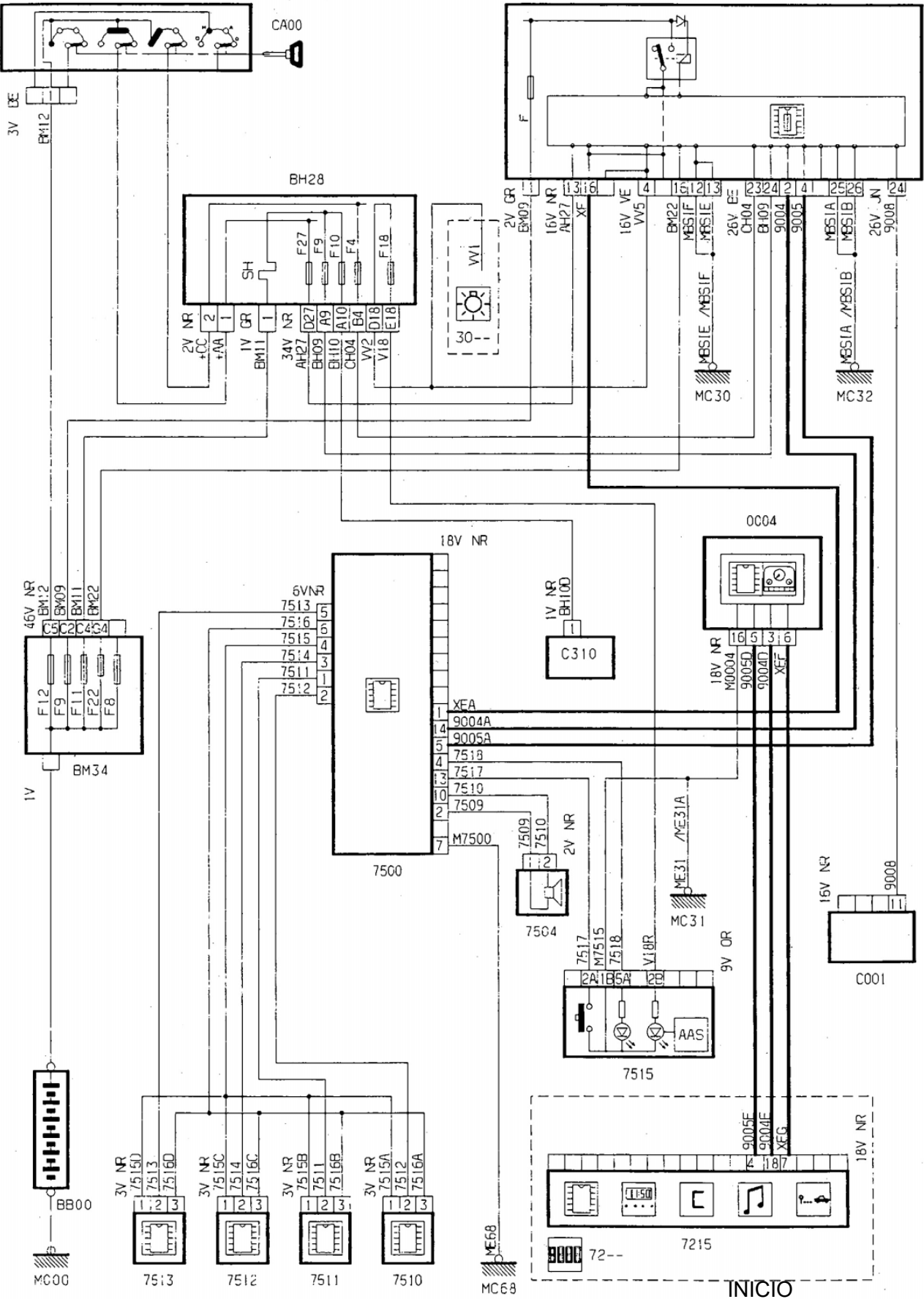

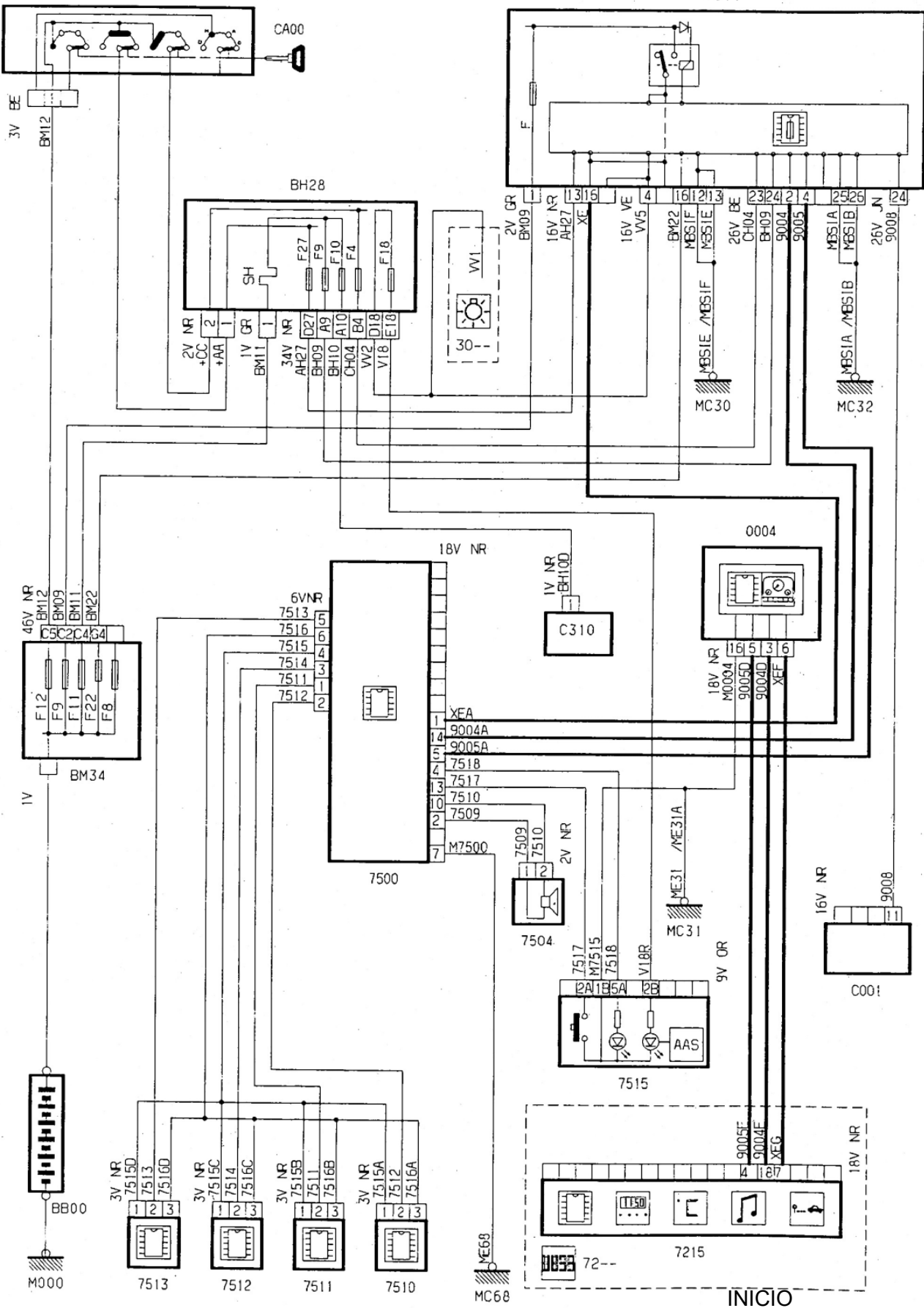

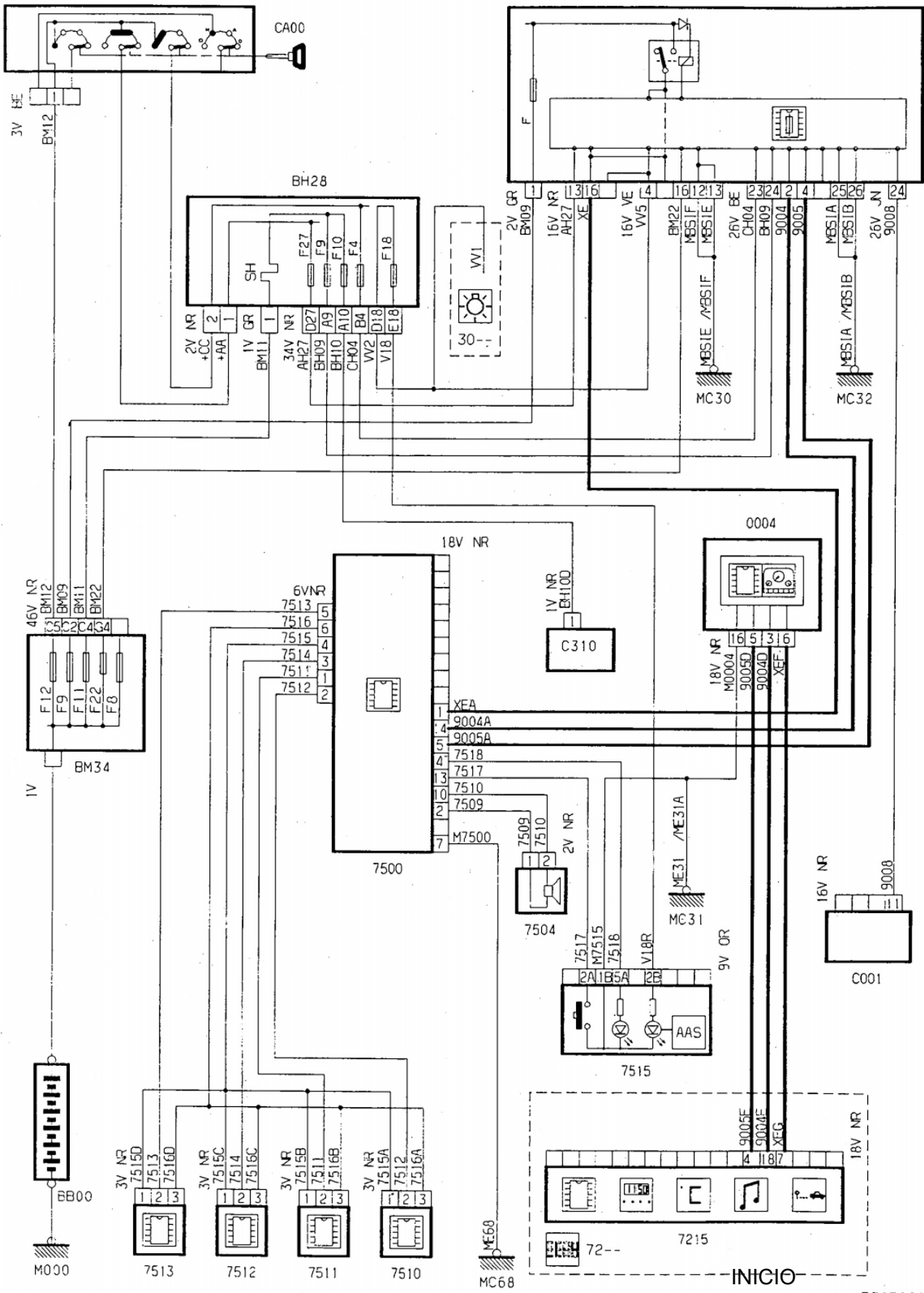

Ordenador de abordo

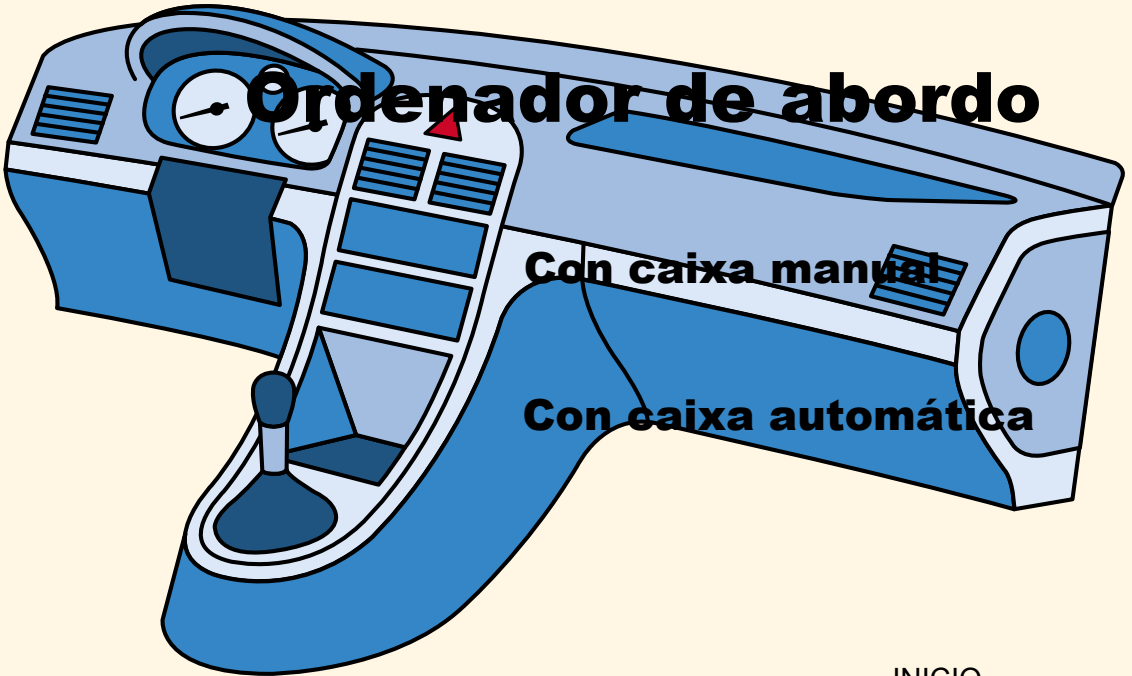

Con caixa manual

Con caixa automática

INICIO

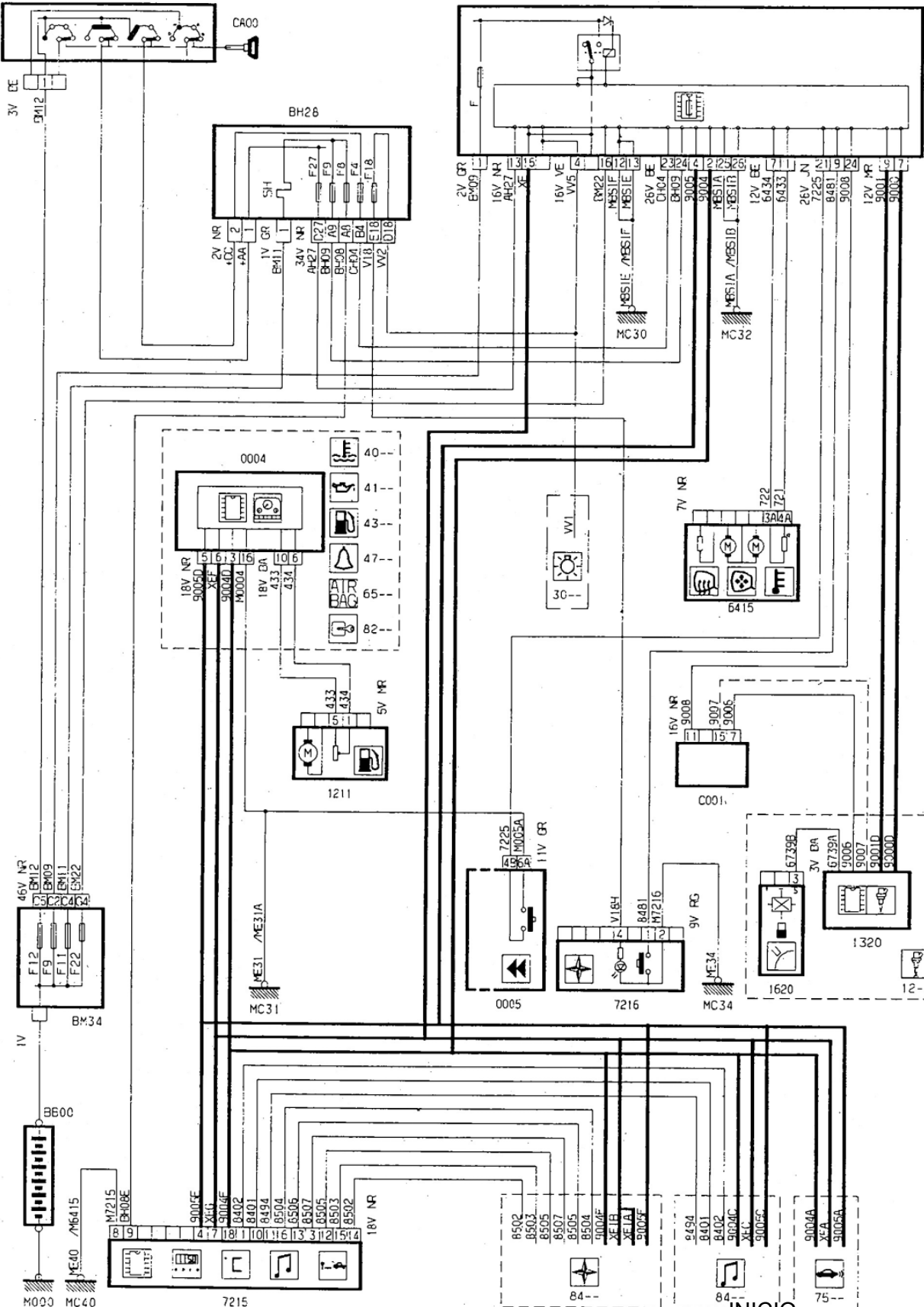

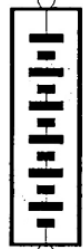
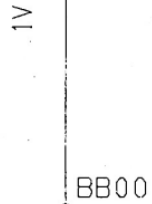
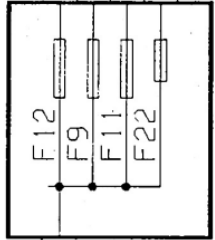
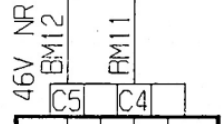
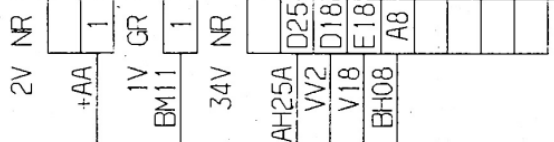
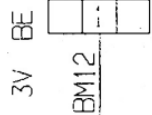
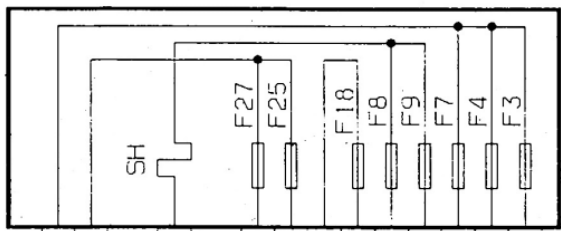
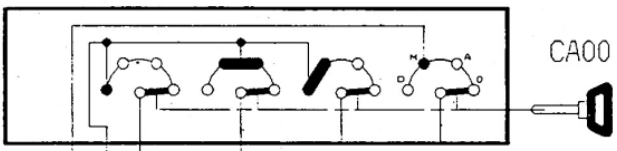

M000

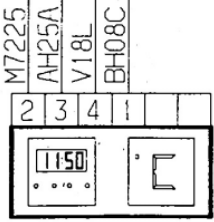
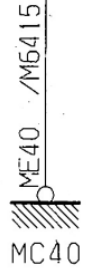

7225

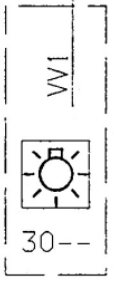

30

INICIO

Seguridade

Airbags e pretensores

Antiarranque

Antiarranque con caixa automática

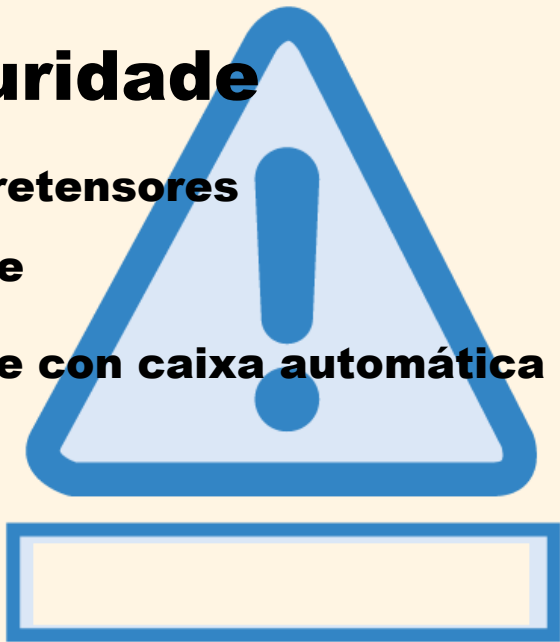

INICIO

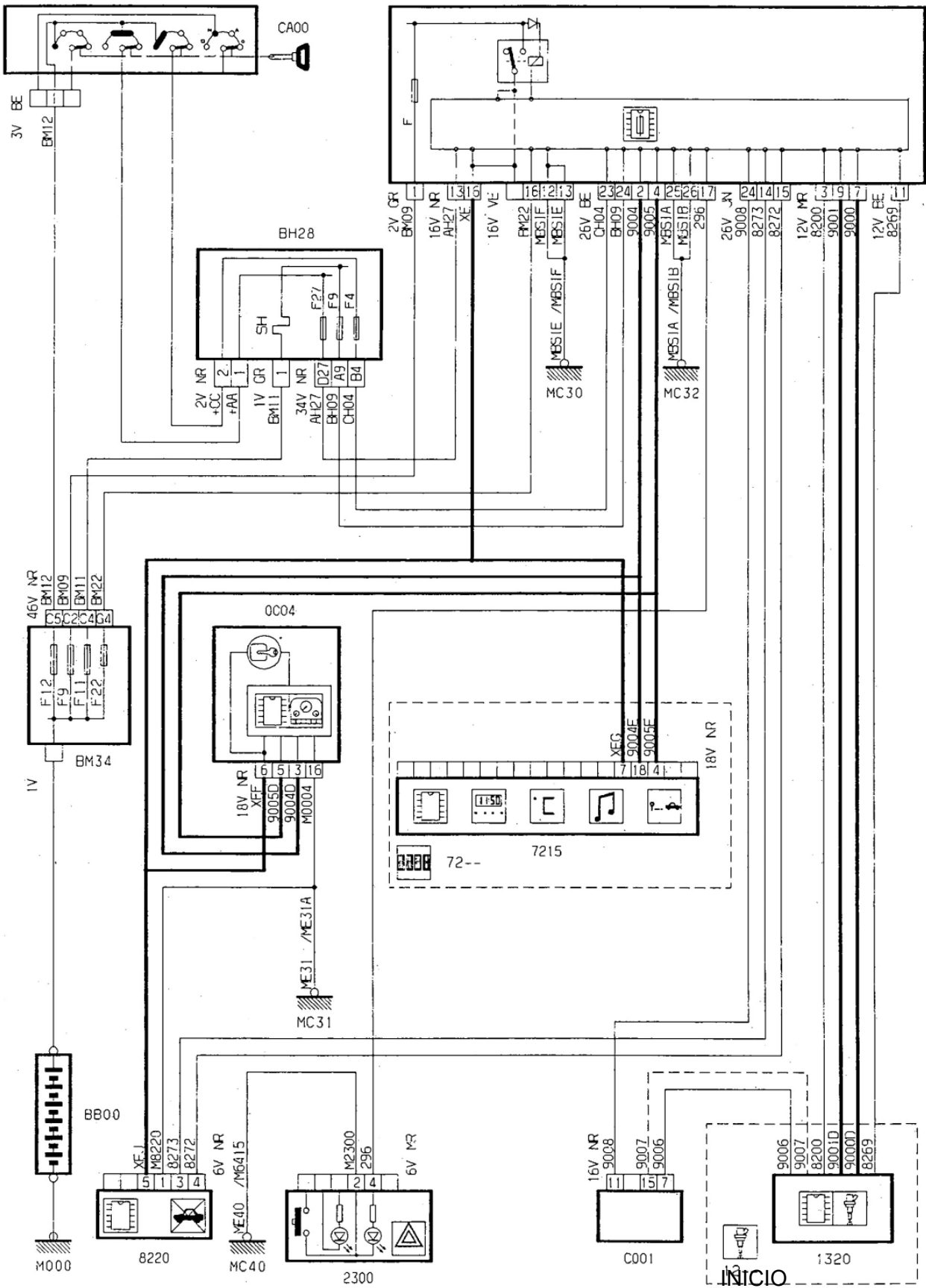

Peeche centralizado

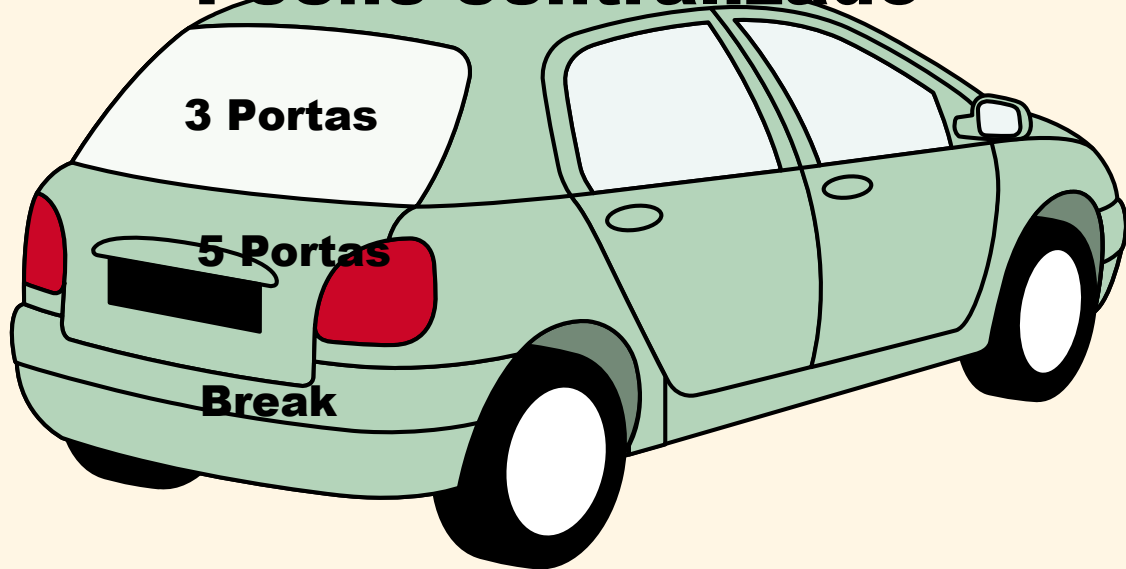

3 Portas

5 Portas

Break

INICIO

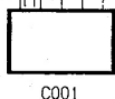
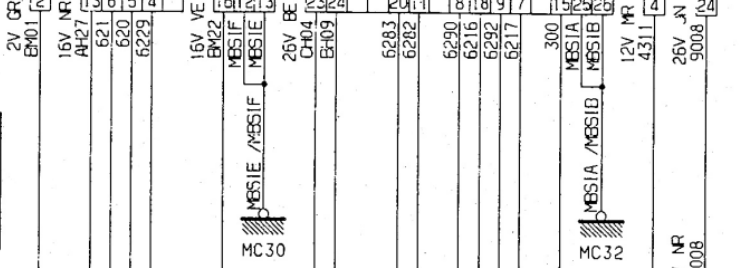
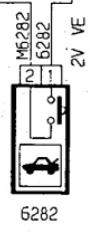
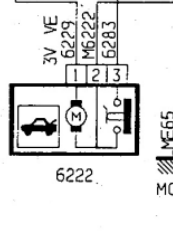
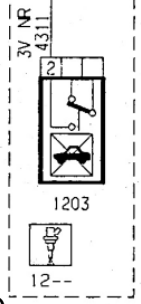
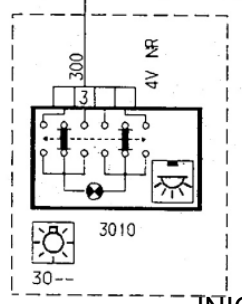
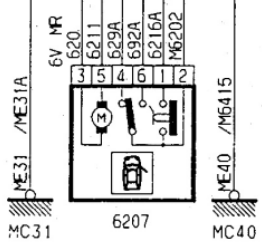
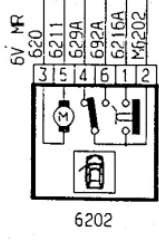
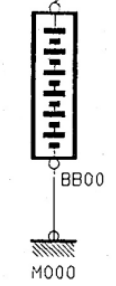
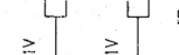
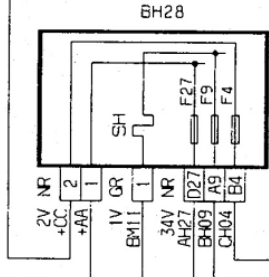
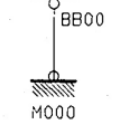
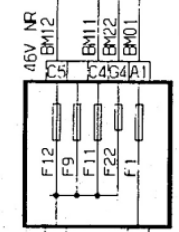
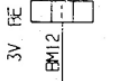
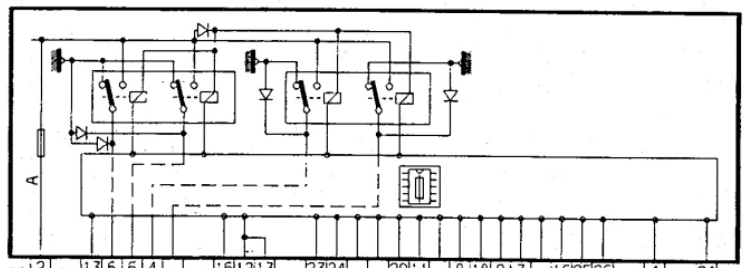
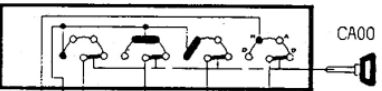

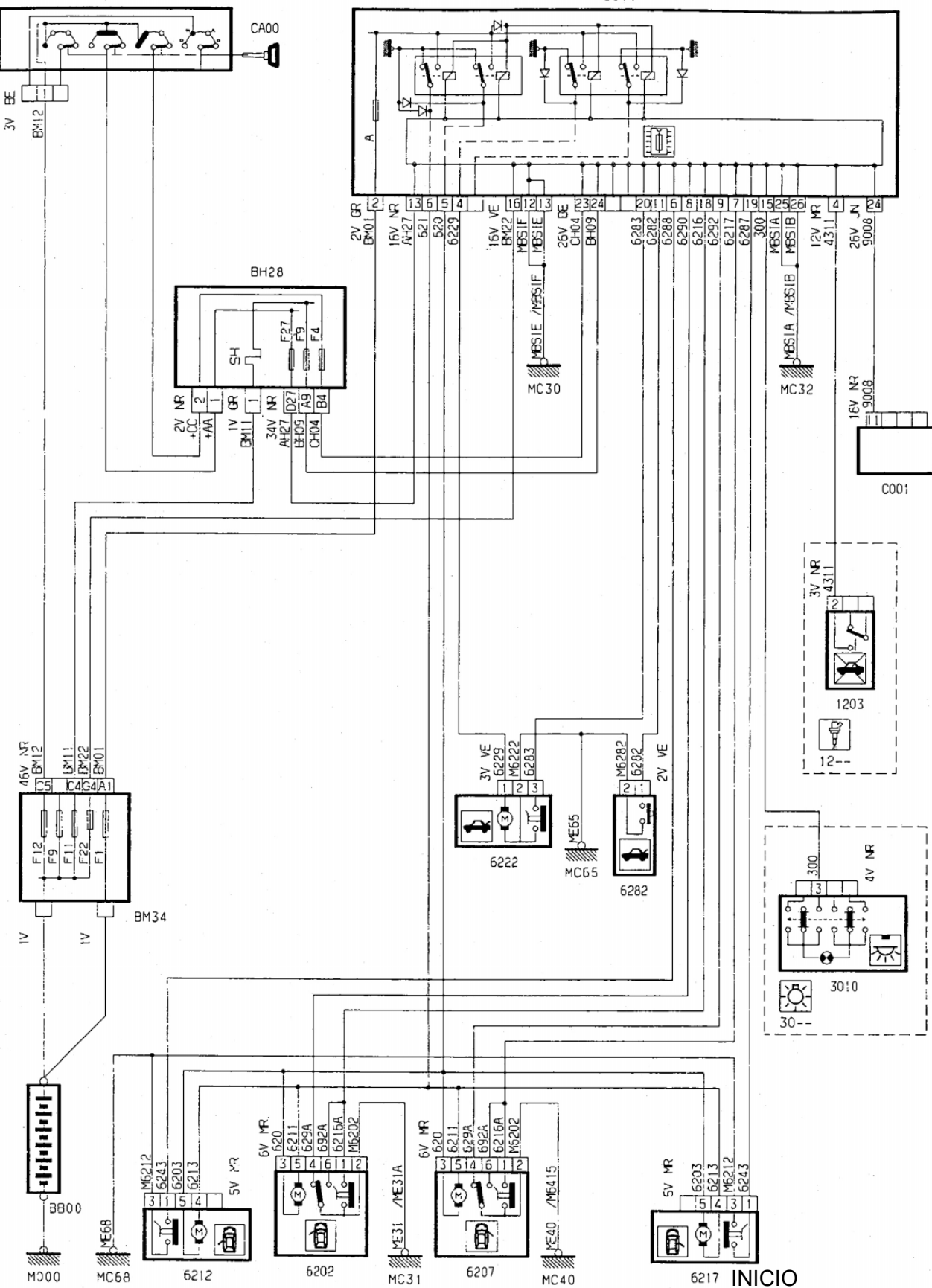

INICIO

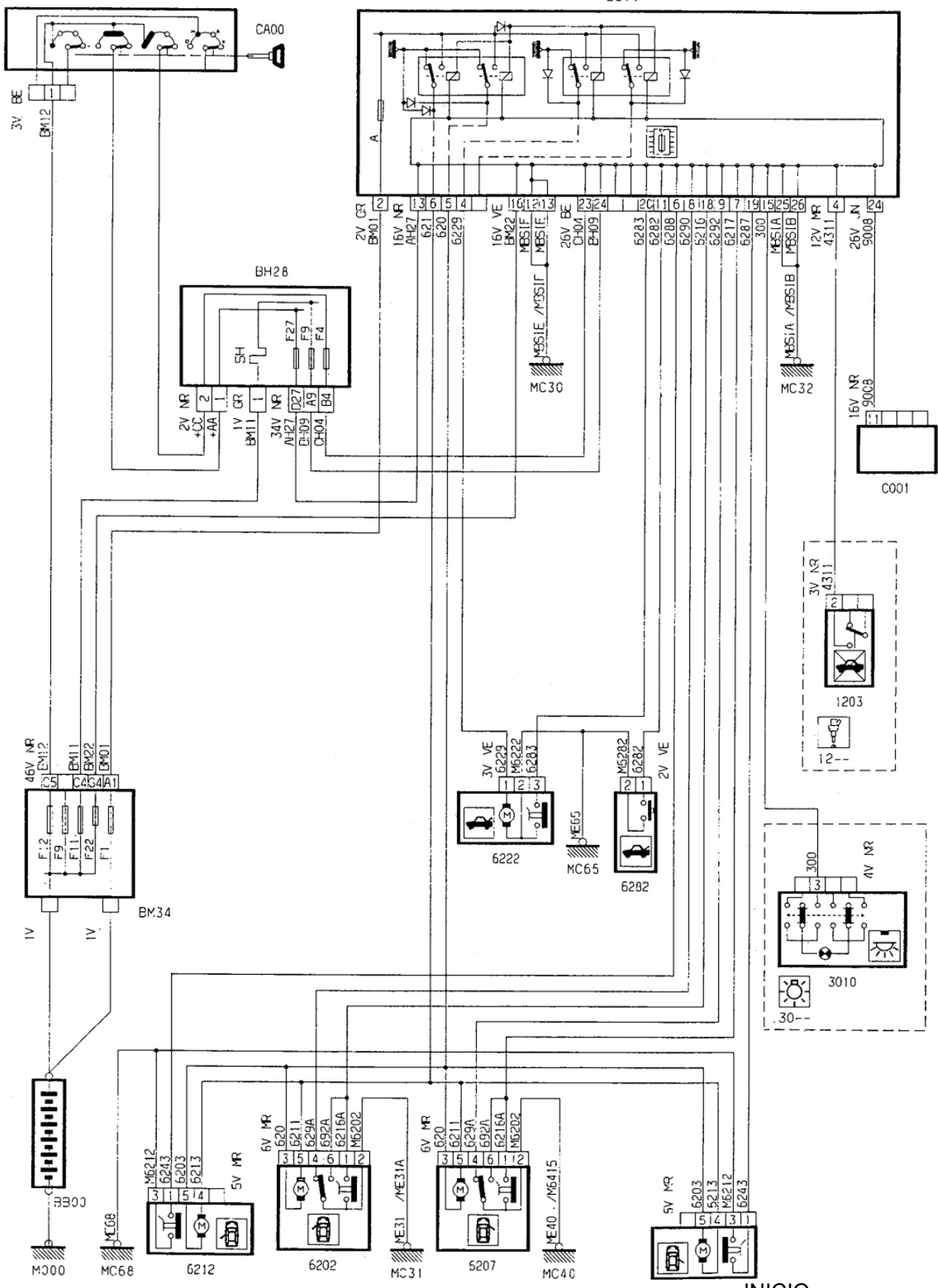

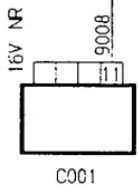
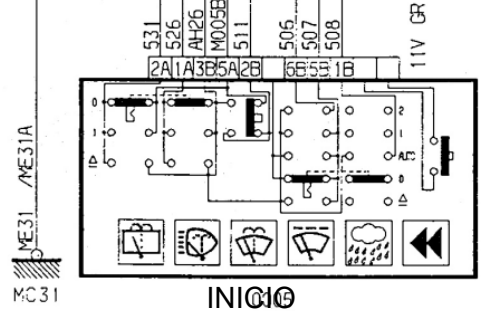
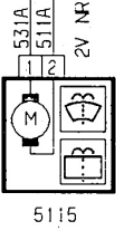
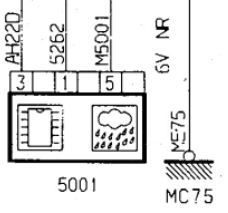
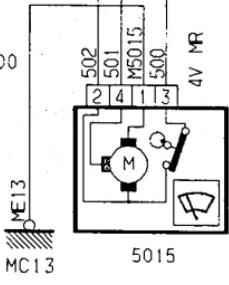
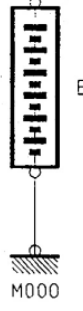
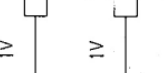
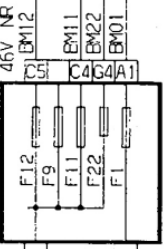
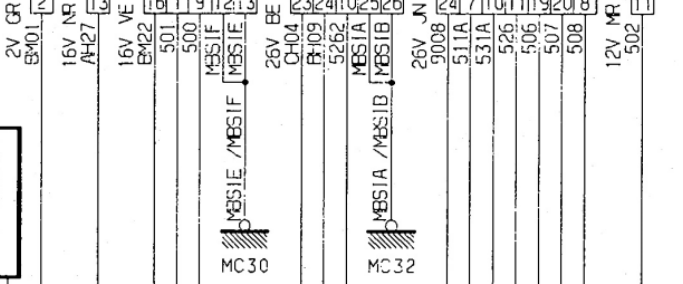
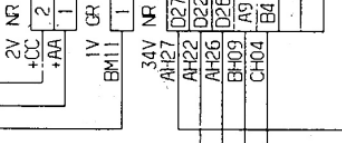
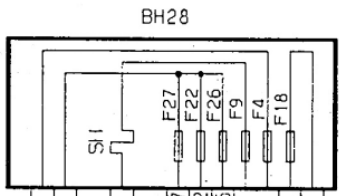
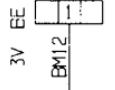
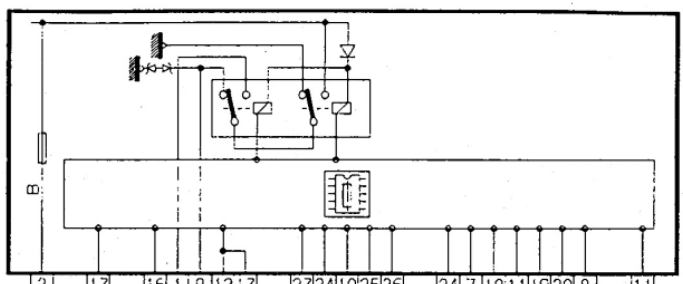
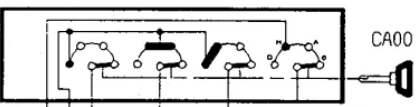

Limpa e lava luneta traseira

3 Portas

5 Portas

Break

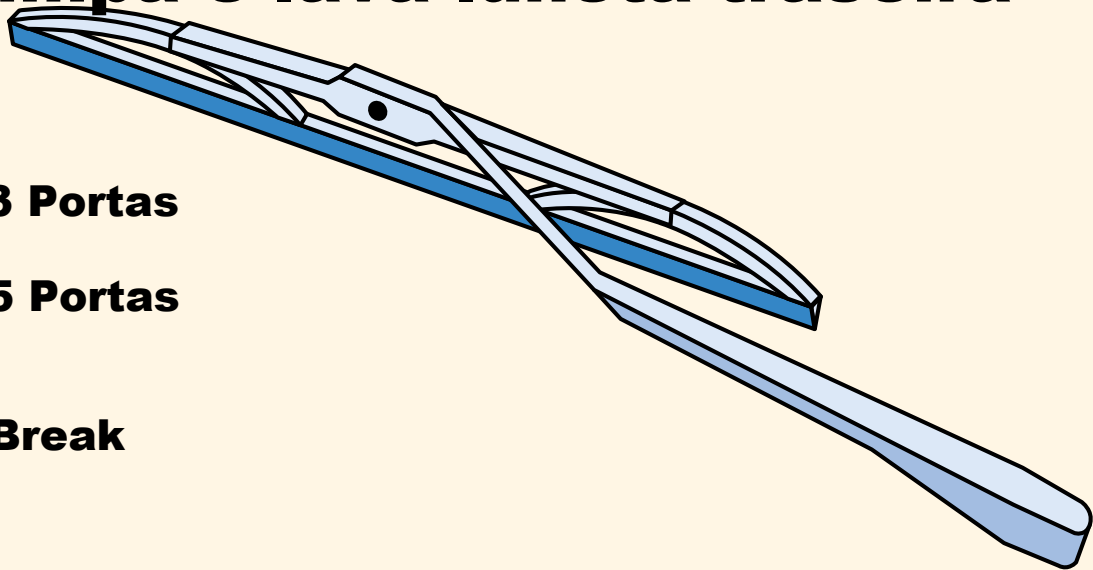

INICIO

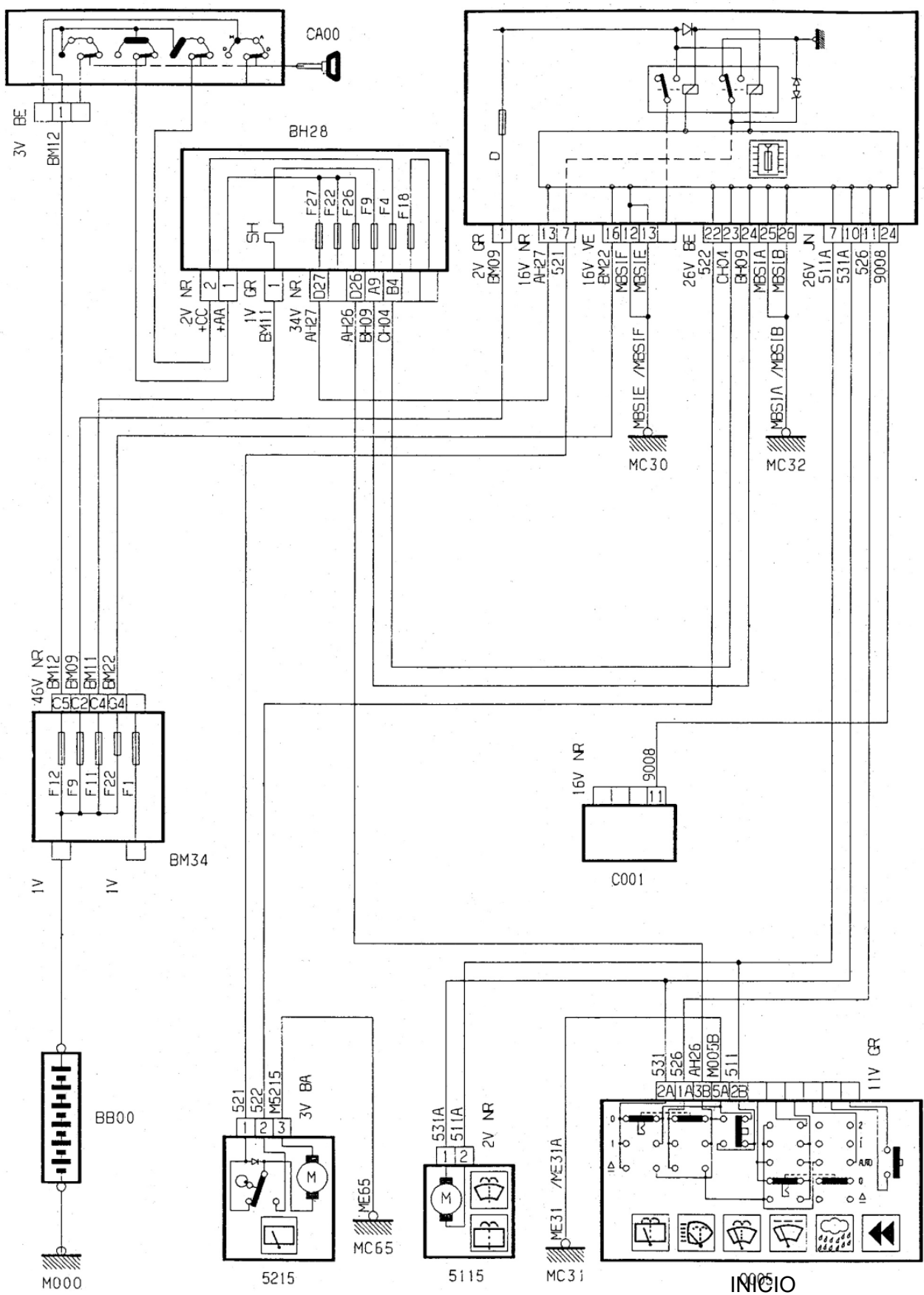

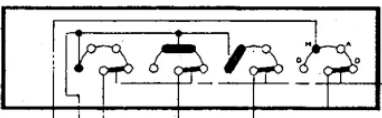

CA00

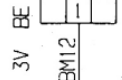

BH28

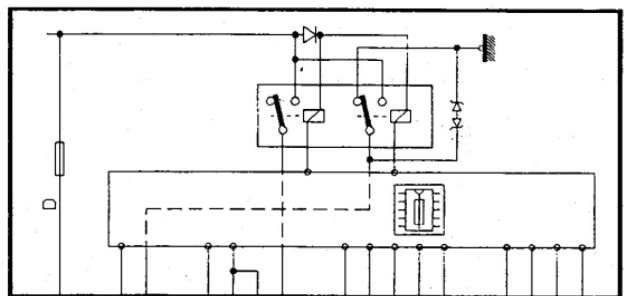
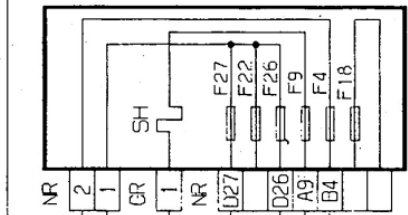

2V NR BM09
16V NR AH27 13 7
521
16V VE BM22 16 12 13
MBS1F MBS1E
MBS1E / MBS1F
26V BE 522
CH04 BM09 22 23 24 25 26
MBS1A MBS1B
MBS1A / MBS1B
26V JN 511A 7 10 11 24
531A 526
9008

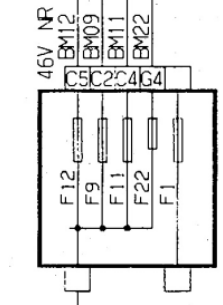

BM34

1V 1V



BB00

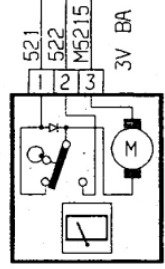

5215

ME65
MC65

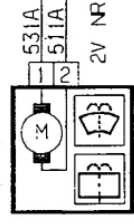

5115

ME31 / ME31A
MC31

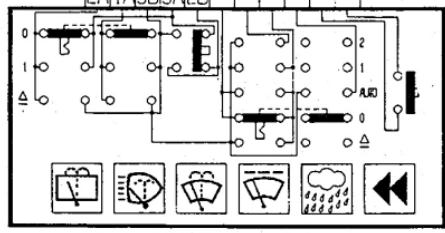
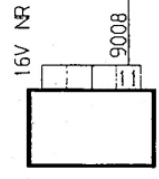

INFC10

Luneta térmica traseira e retrovisores calefactados

3 e 5 Portas

Break

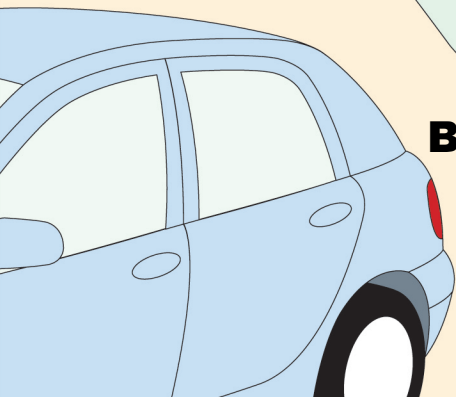

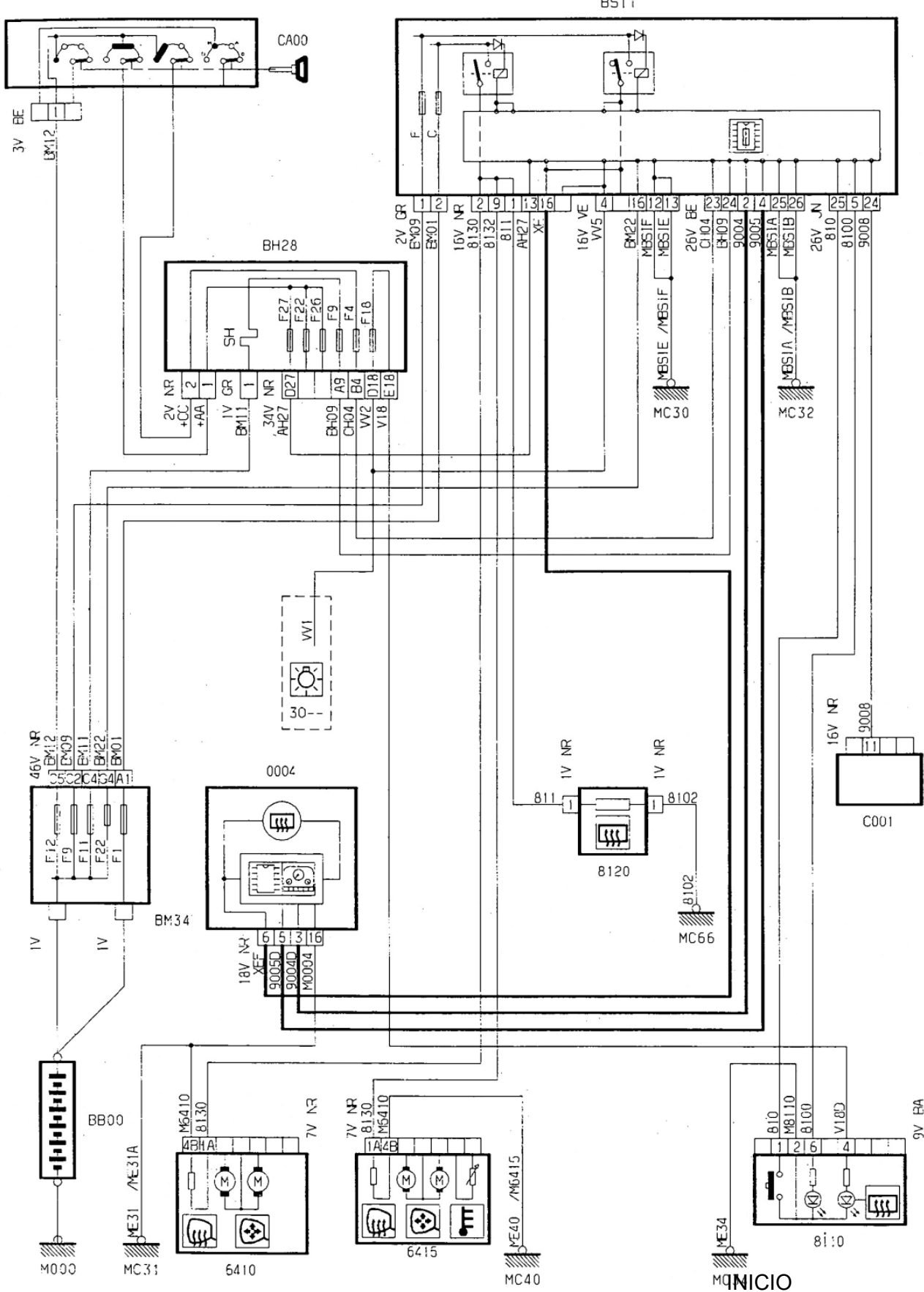

Evaluas

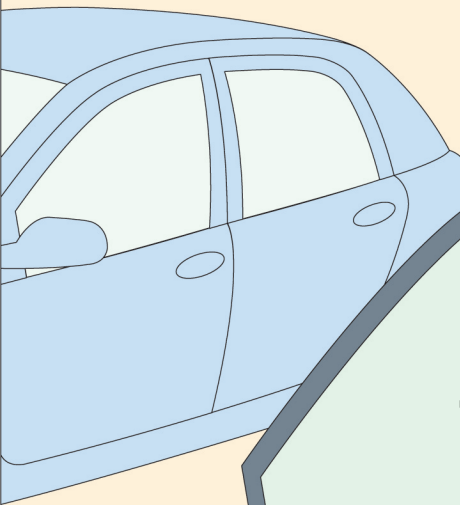

Dianteiros

Dianteiros todos

Traseiros

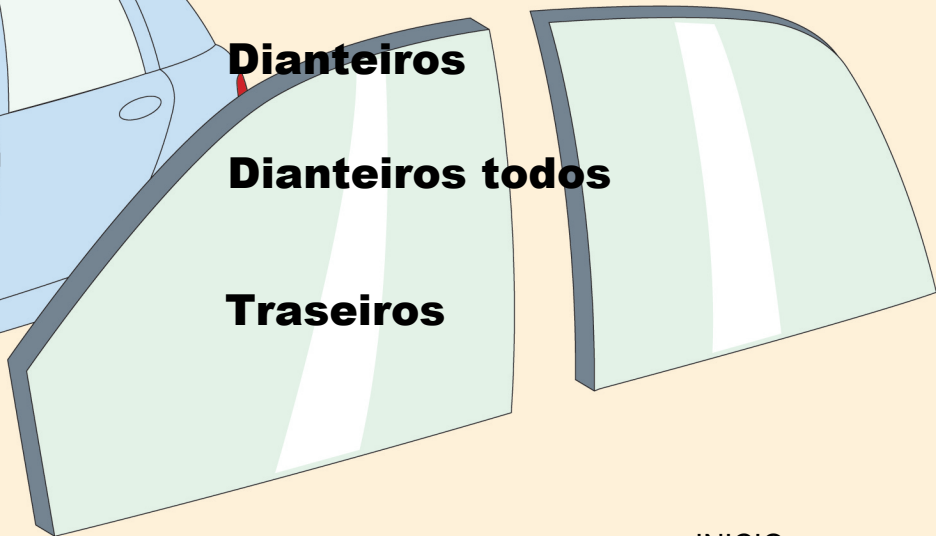

INICIO

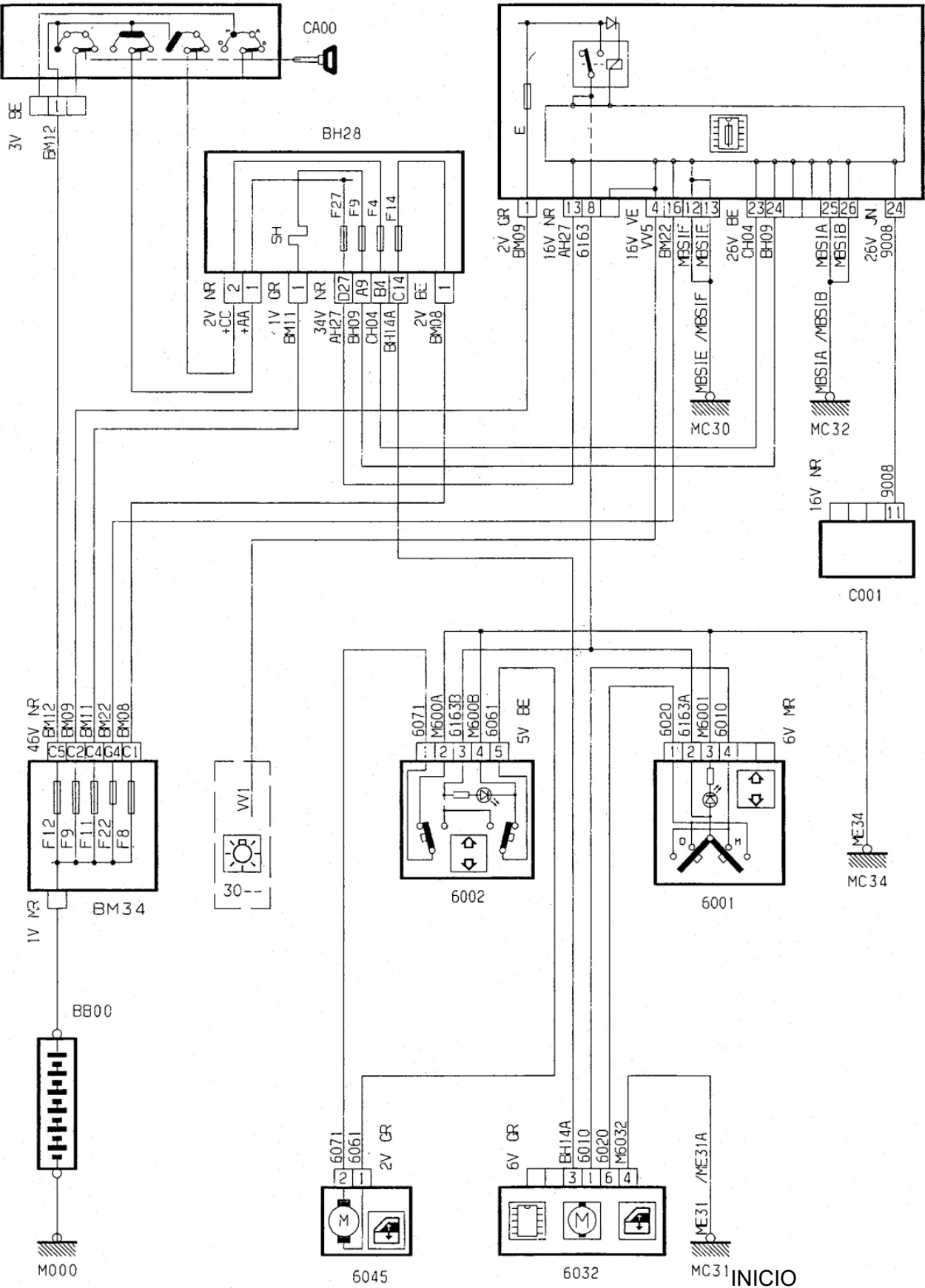

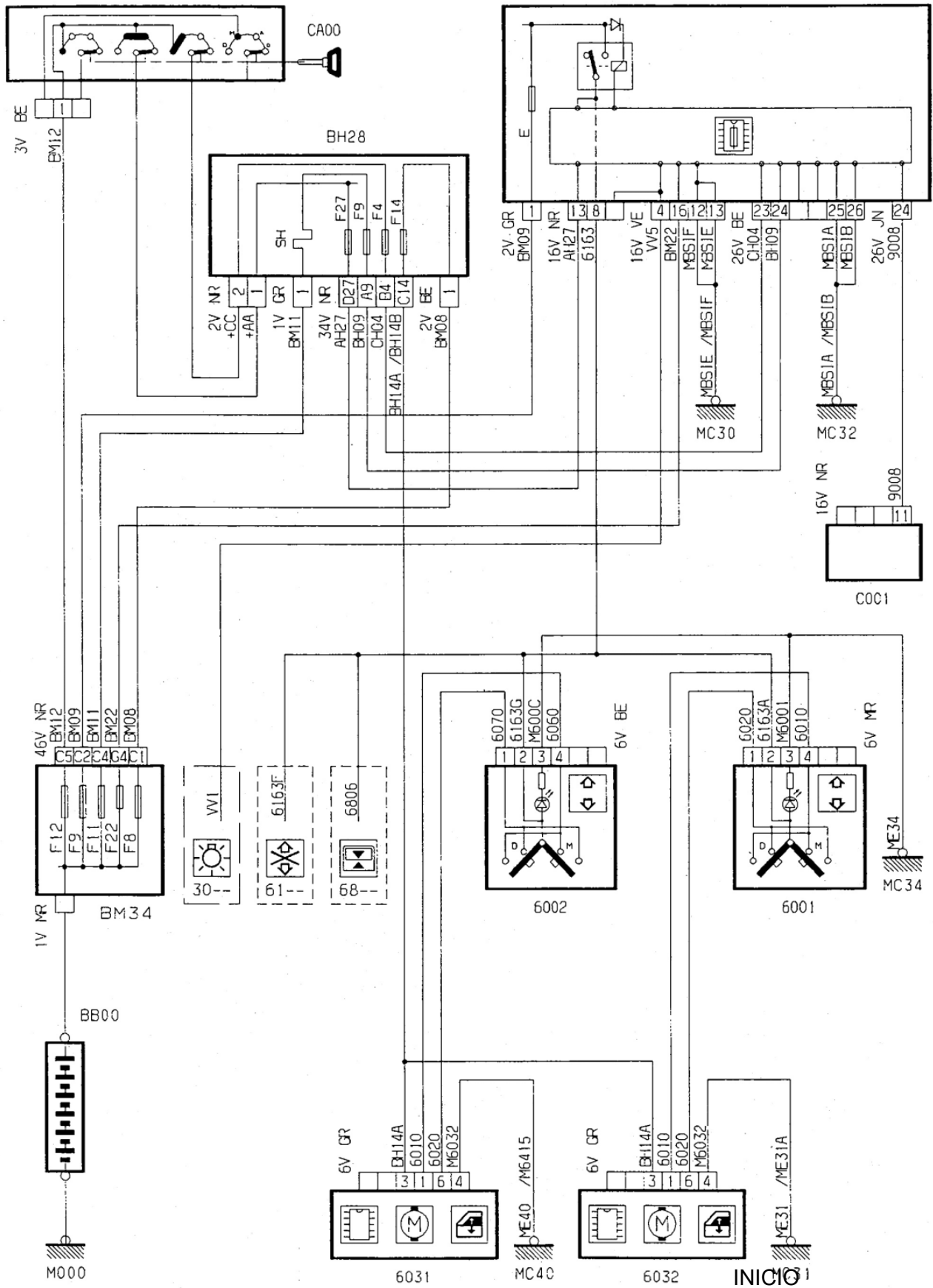

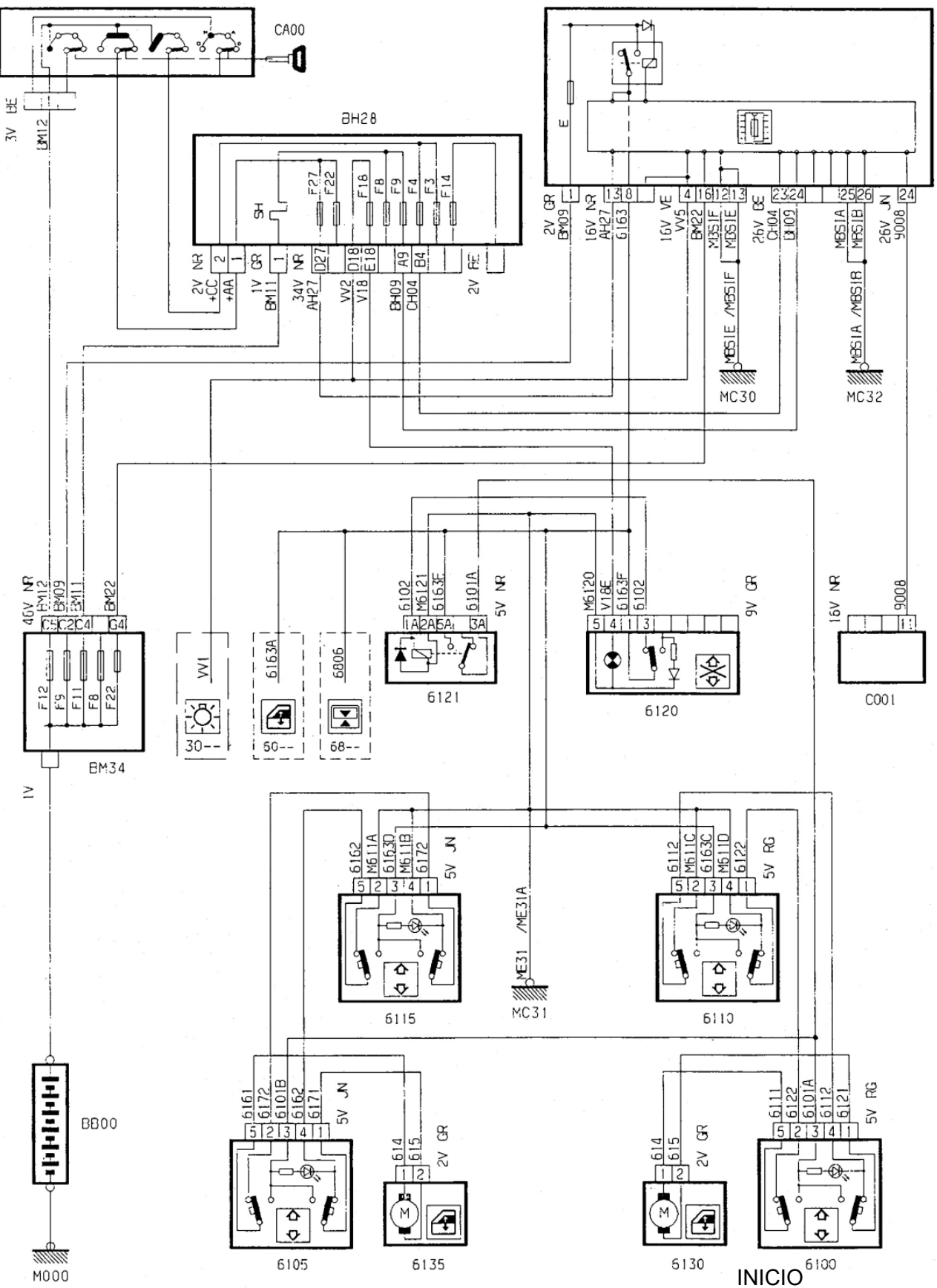

INICIO

BH28

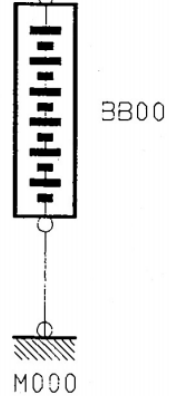
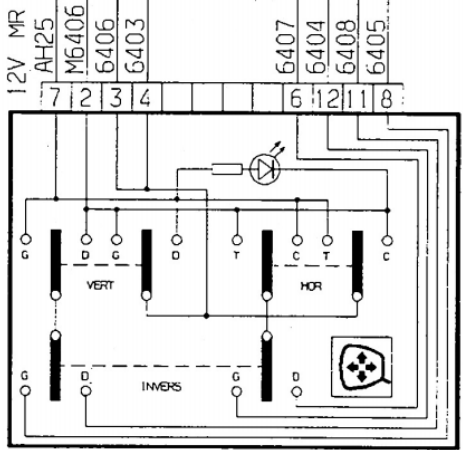
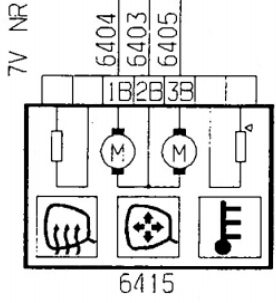
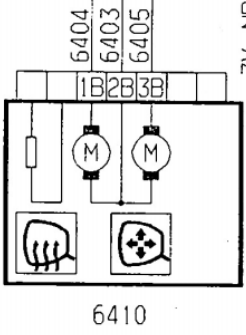
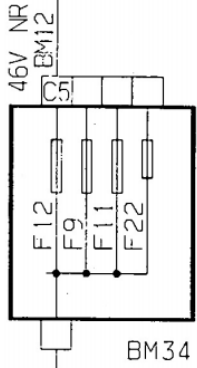
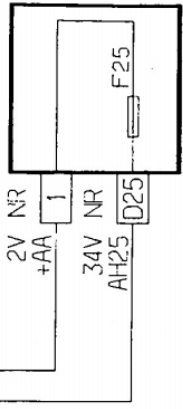
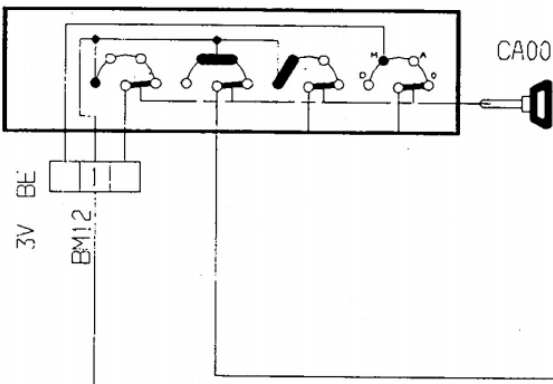

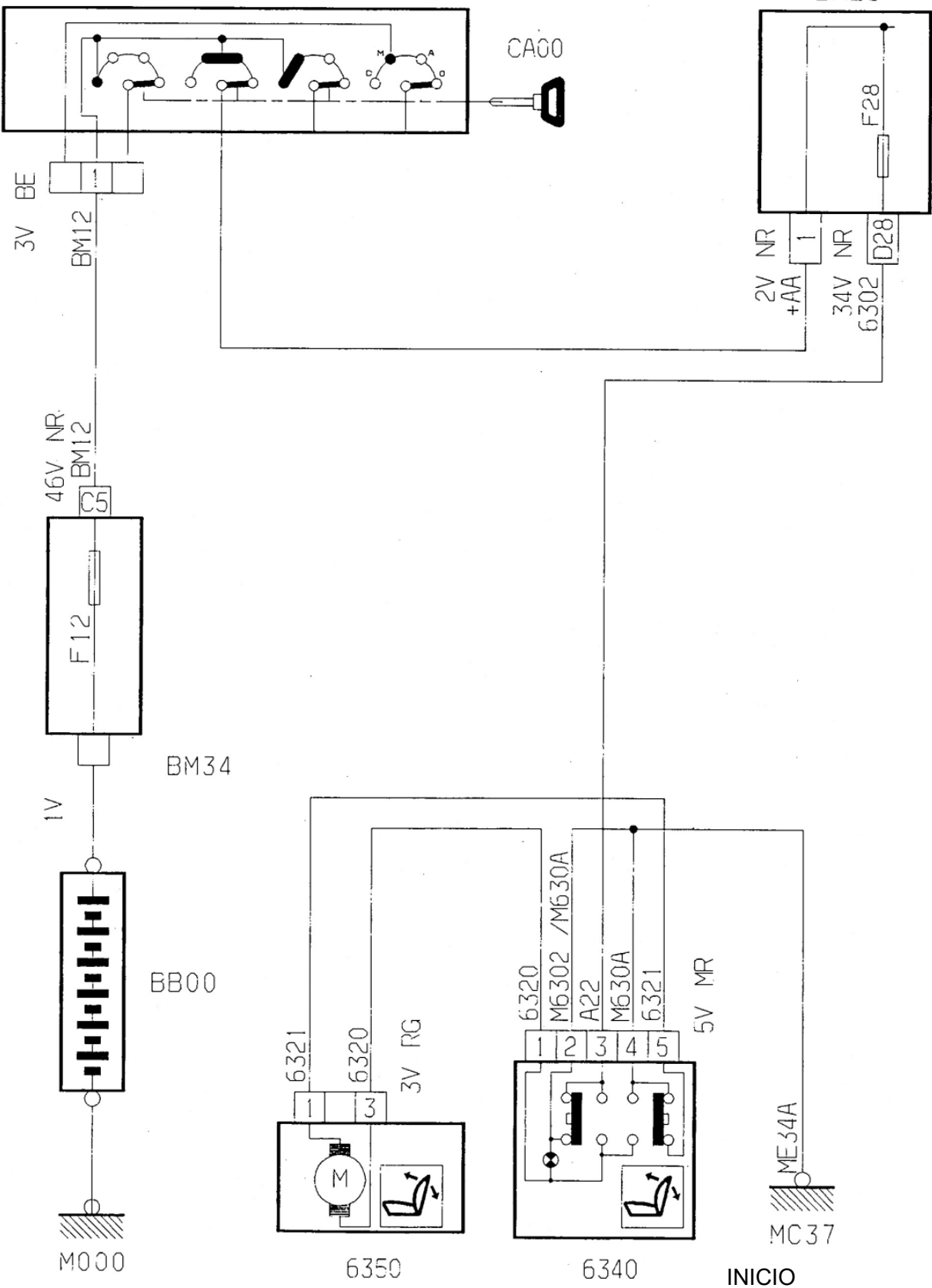

Climatización

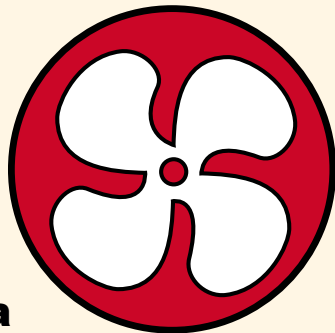
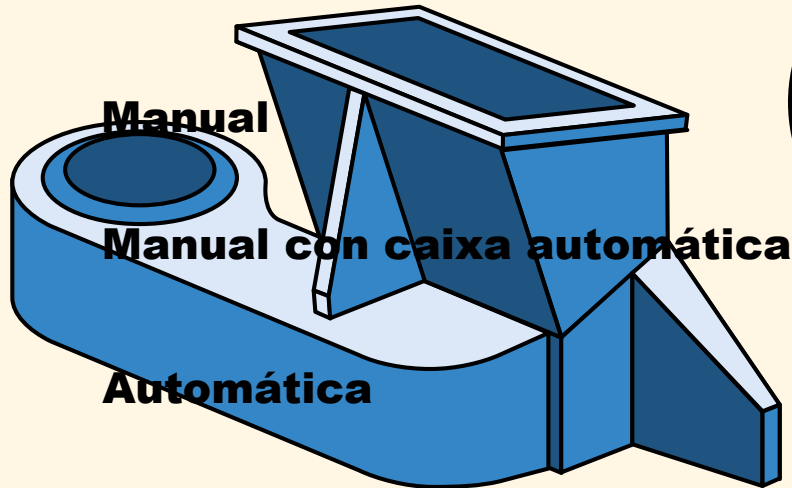

Automática con caixa automática

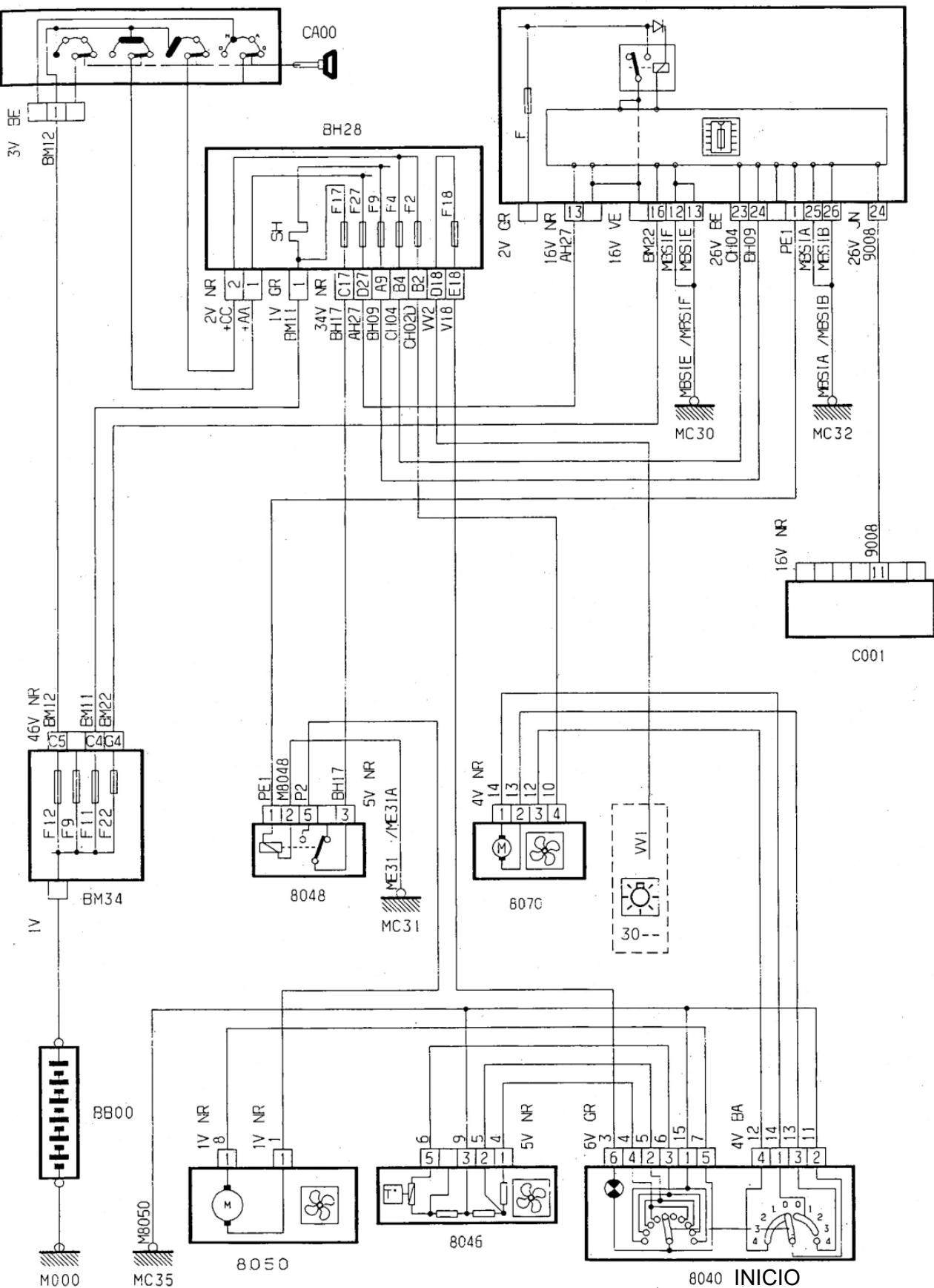

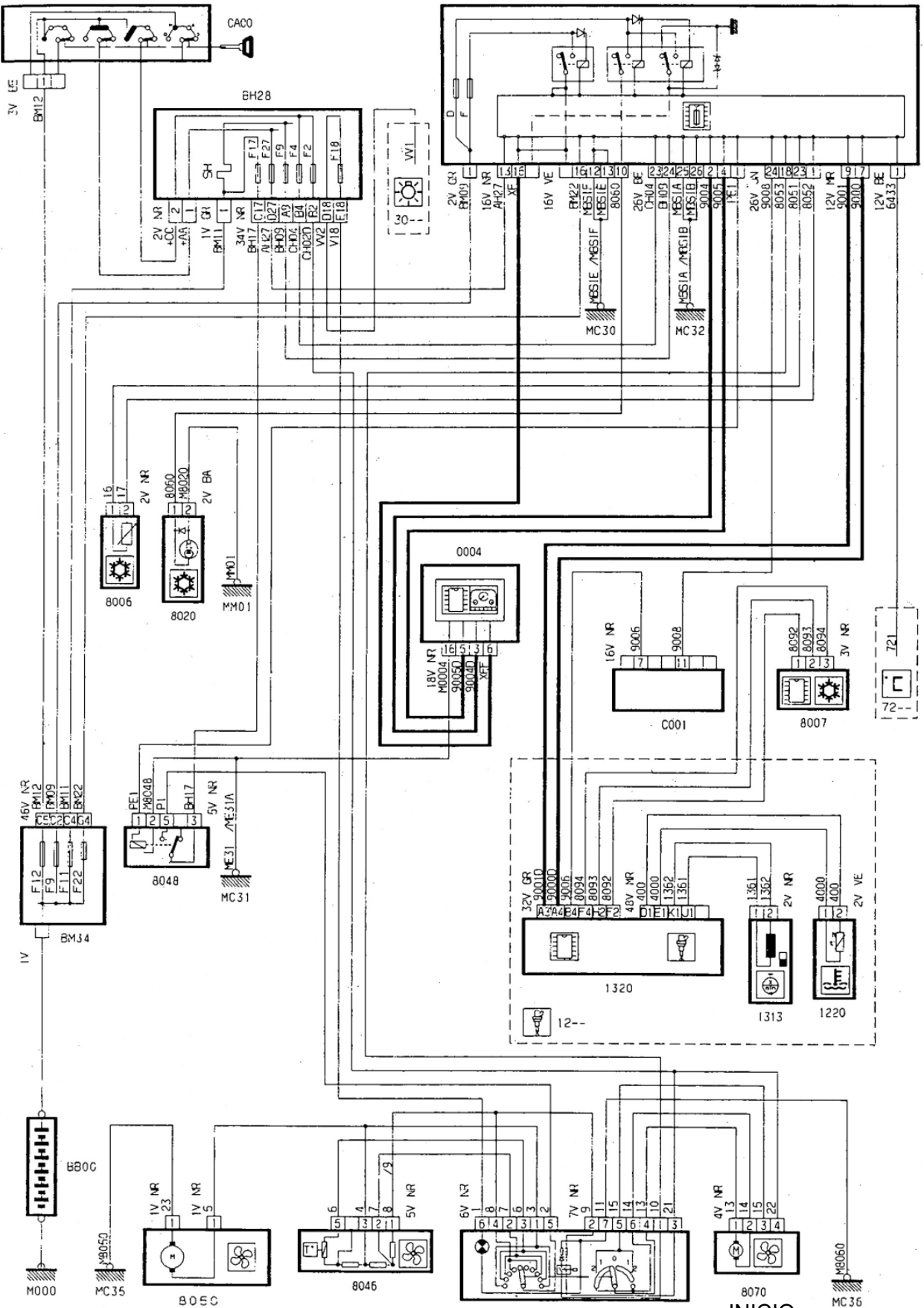

INICIO

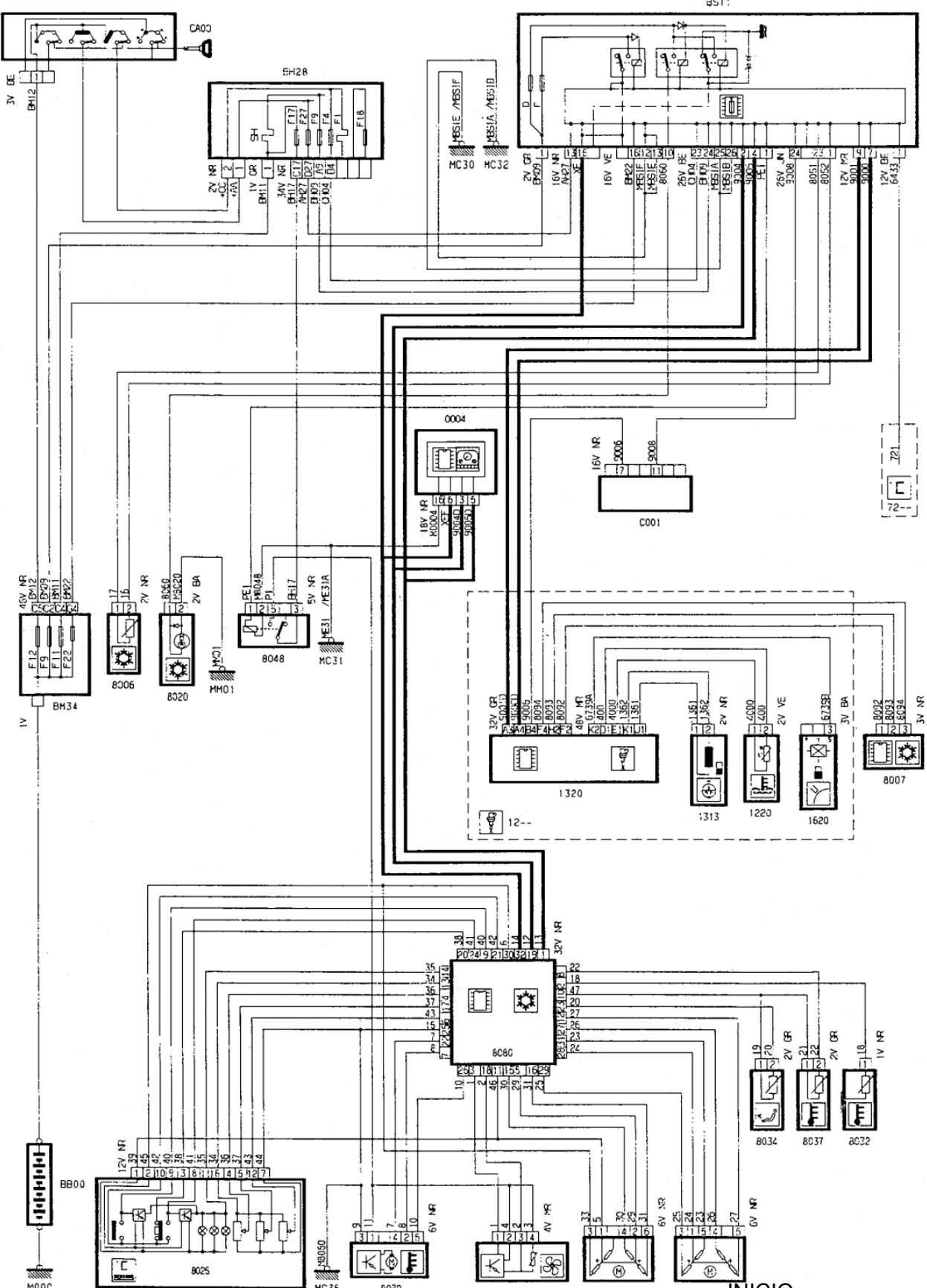

INICIO

Autoradio

3 Portas

5 Portas e Break

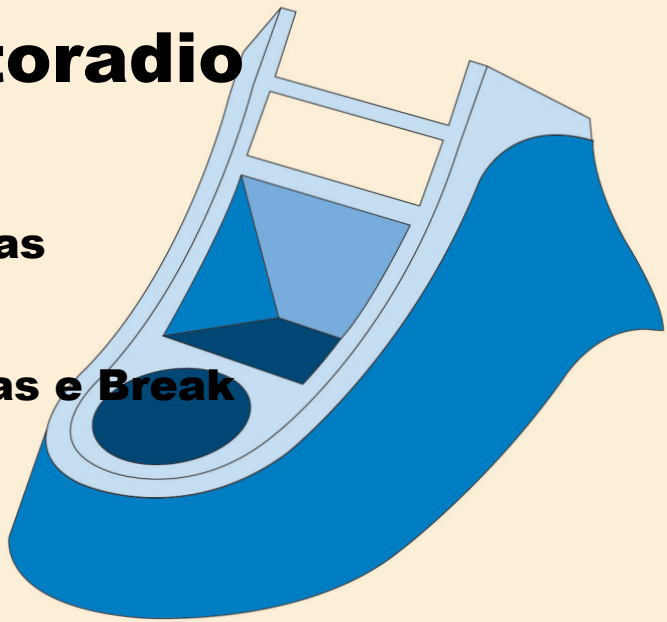

INICIO

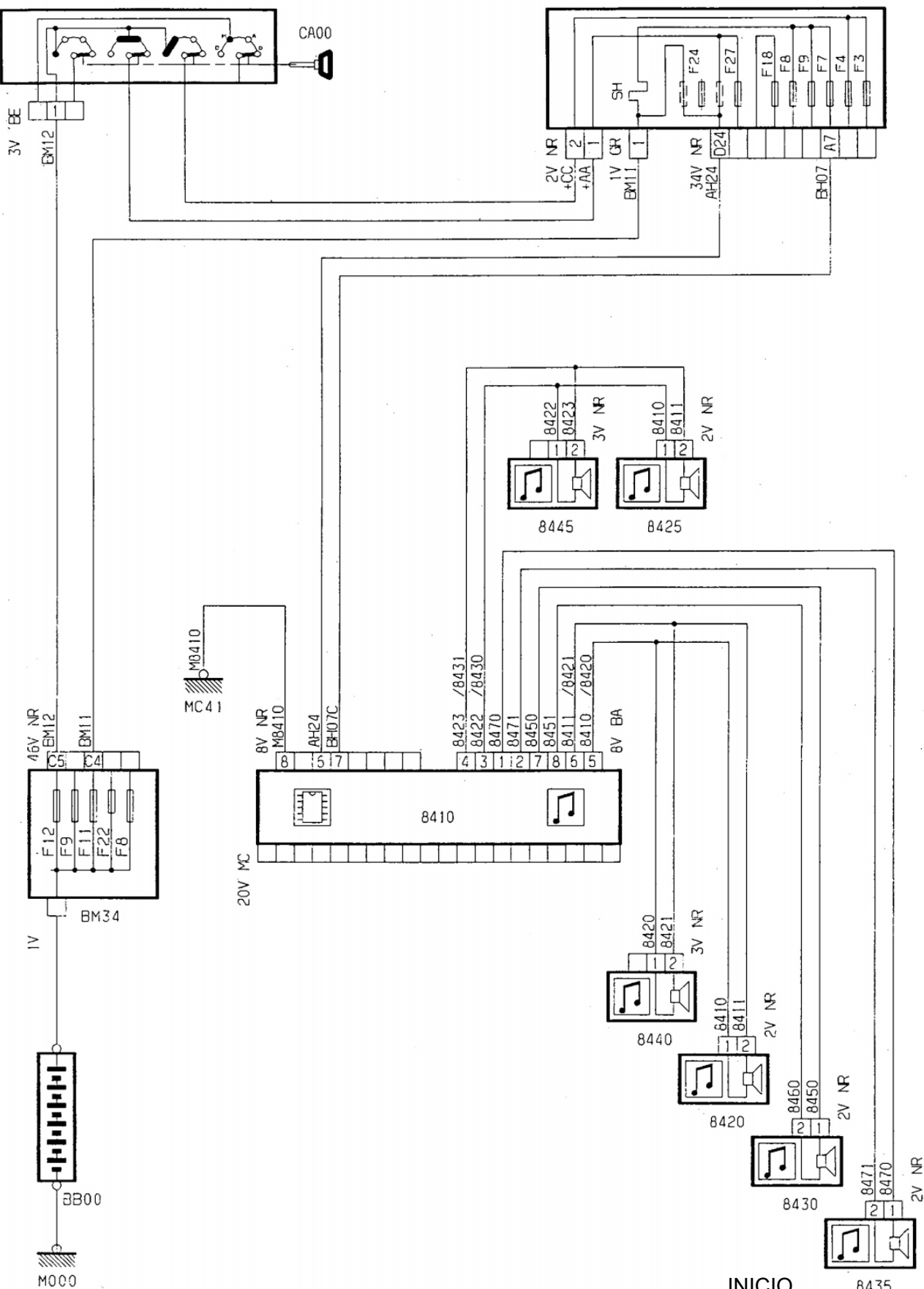

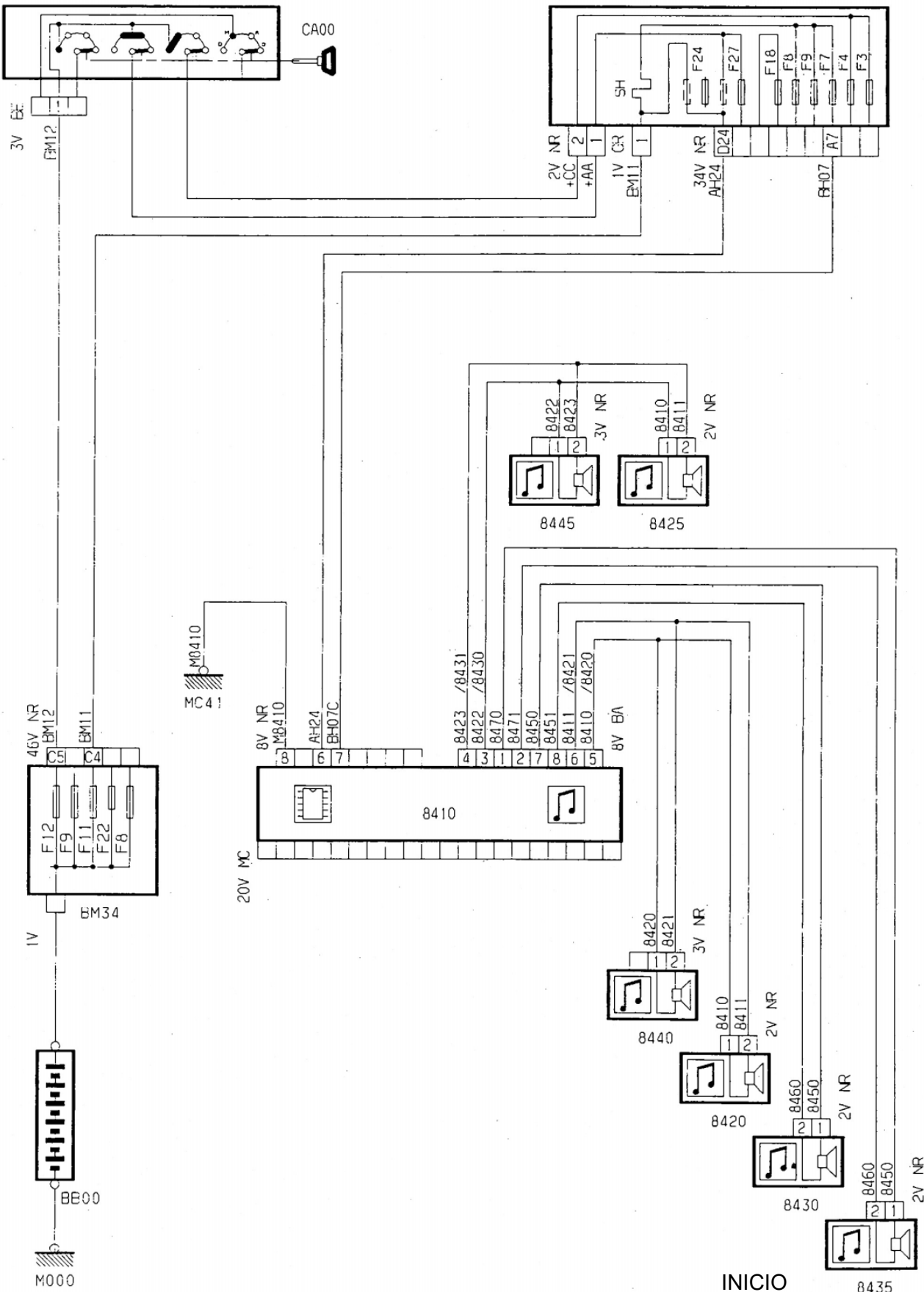

BH28

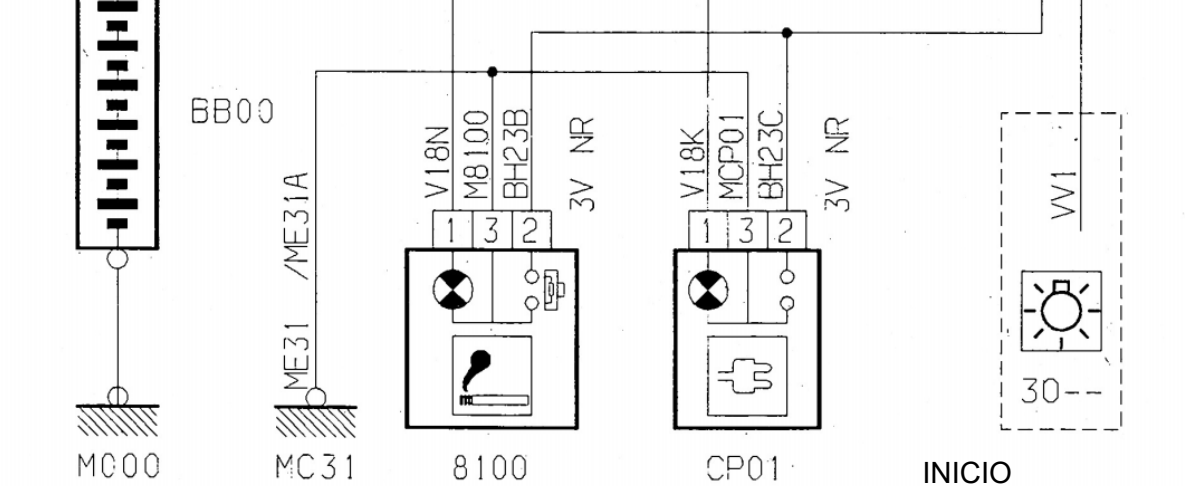
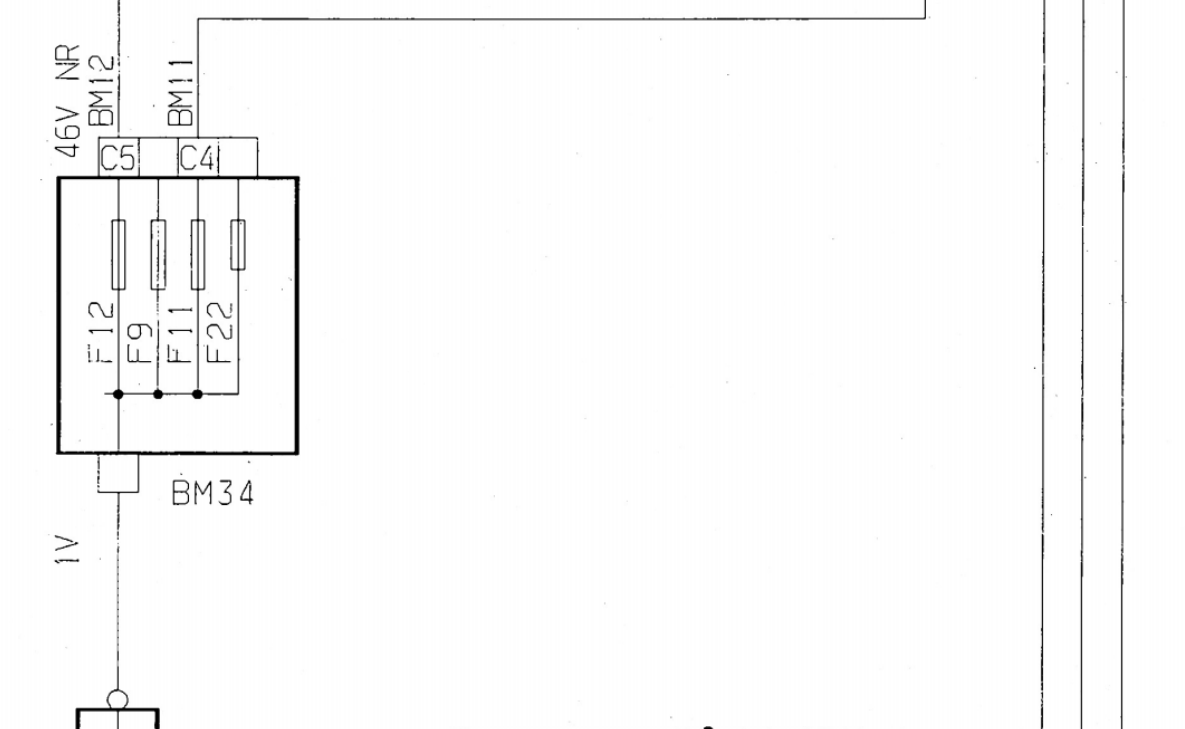
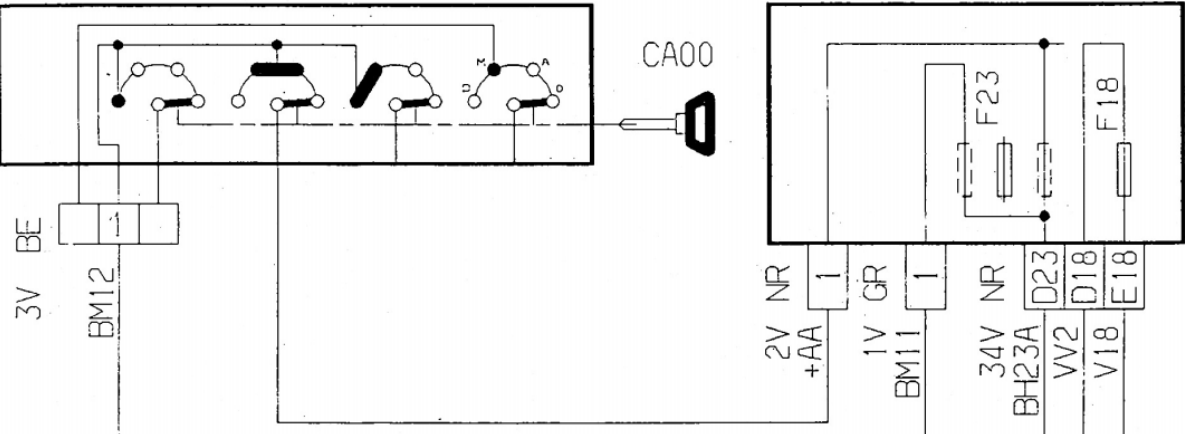

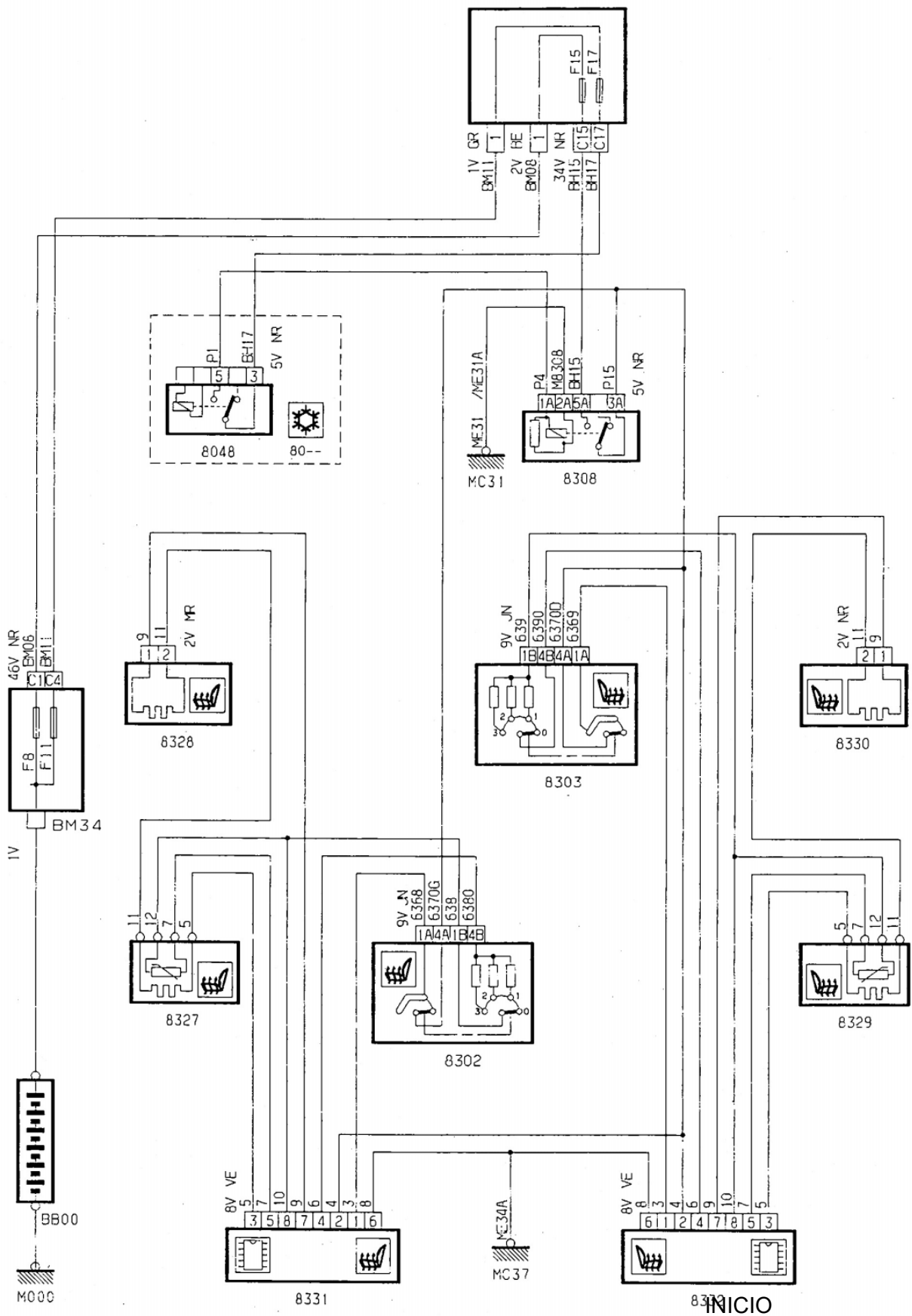

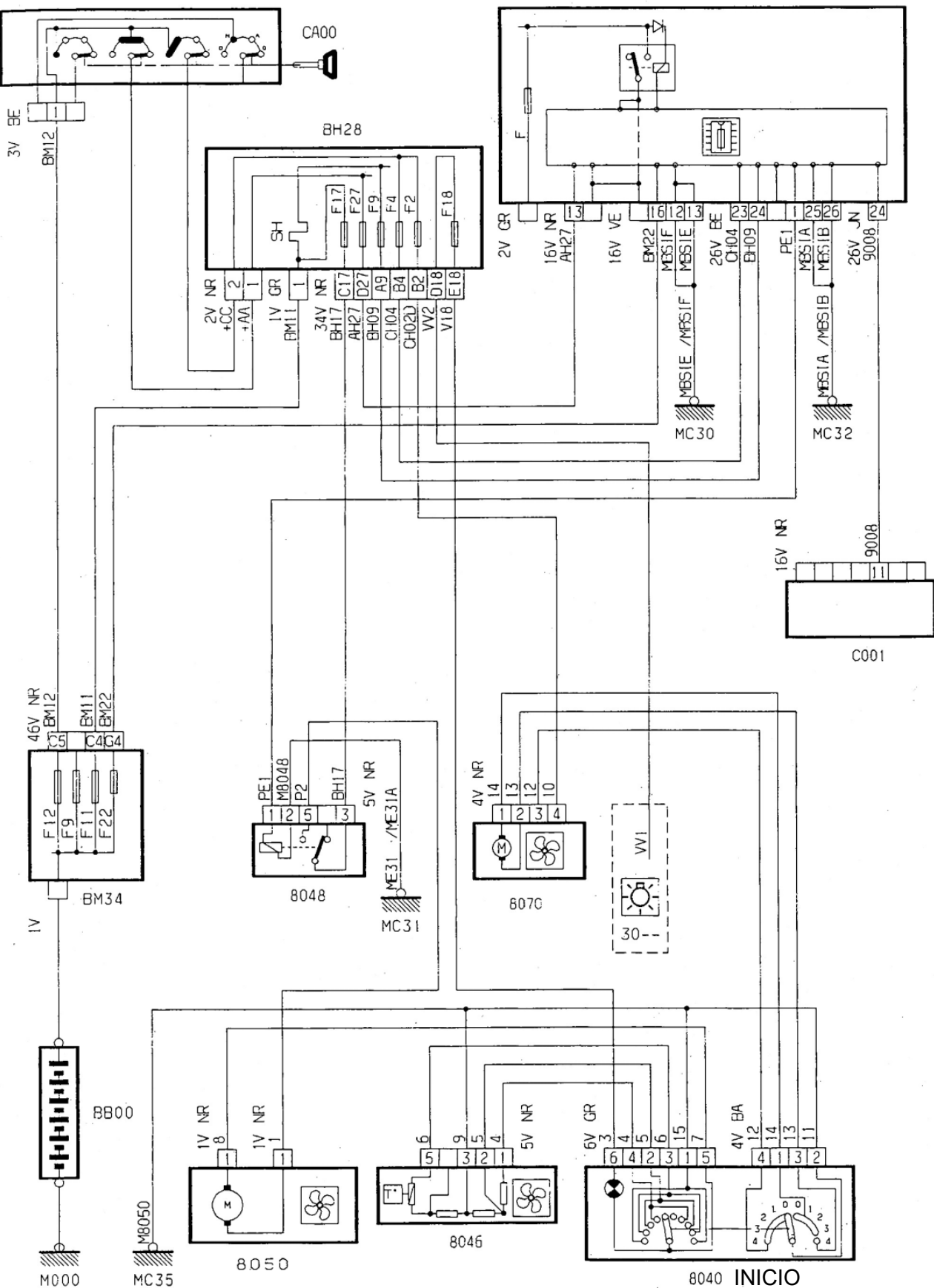

Cableados e localización de componentes

1.-Arquitectura eléctrica

2.-Arquitectura electrónica

3.-Grupo motor propulsor

4.-Axuda a conducción

5.-Sinalización e iluminación

6.-Información conductor

7.-Seguridade

8.-Dispositivos de mando eléctrico

9.-Confort habitáculo

10.-Localización



Portada

Motor de arranque e alternador

Con caixa automática

Motor RHY

Motor RHZ

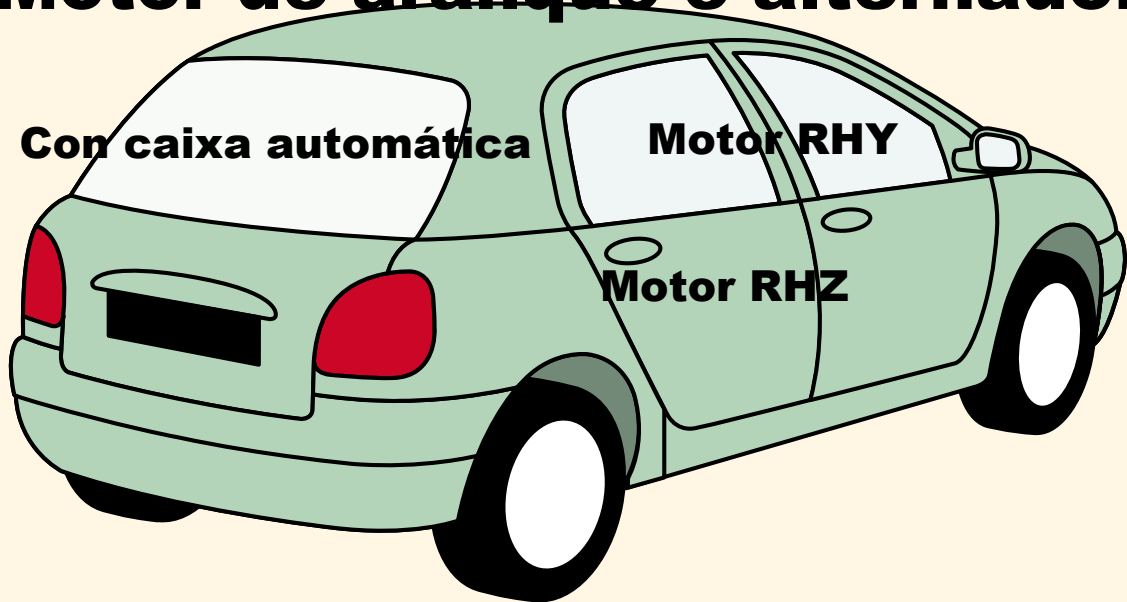

INICIO

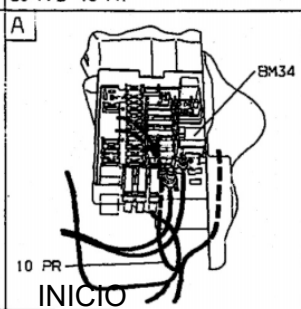
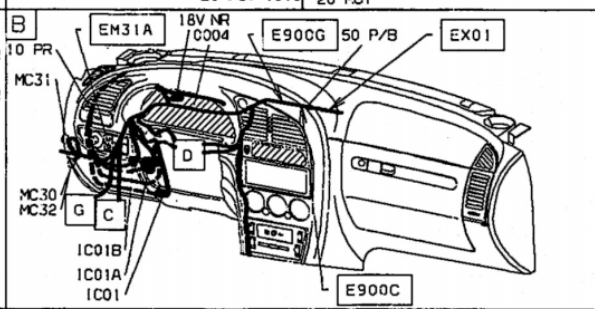
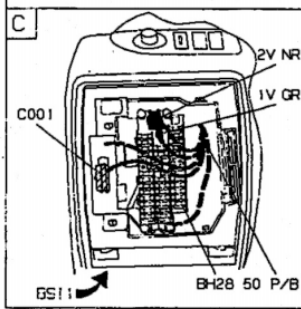
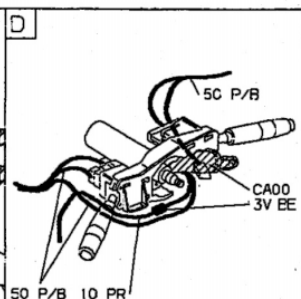
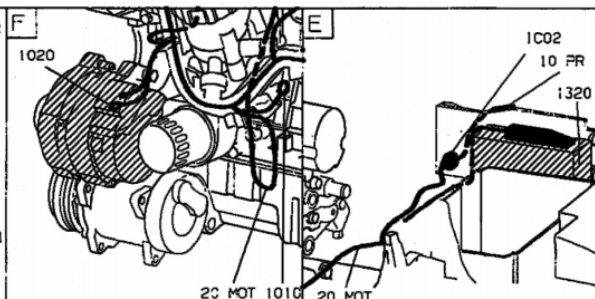
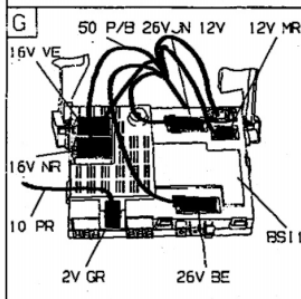
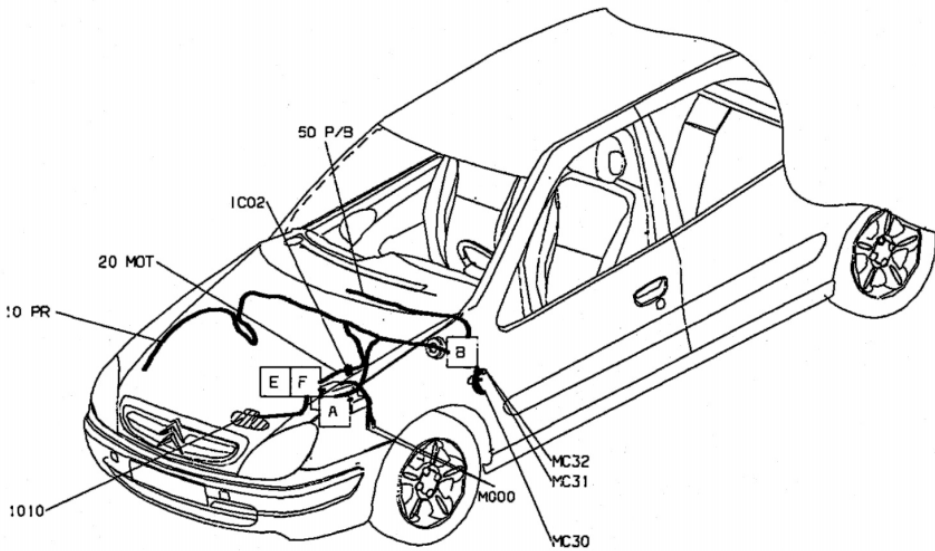

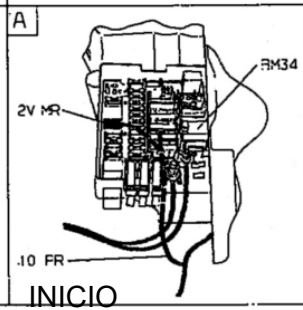
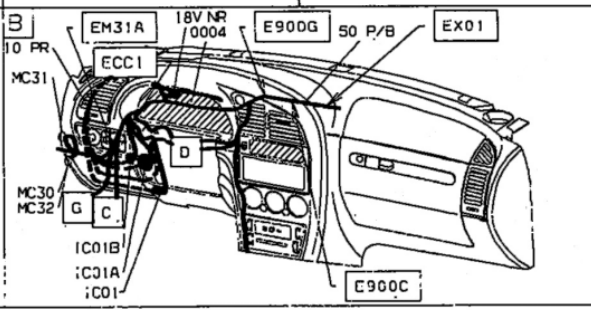
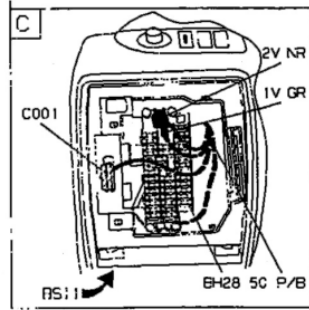
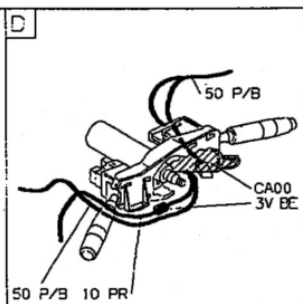
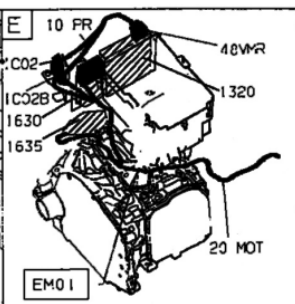
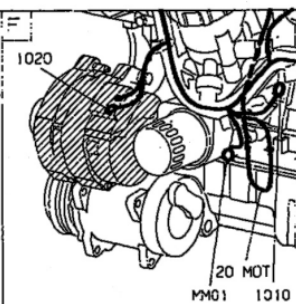
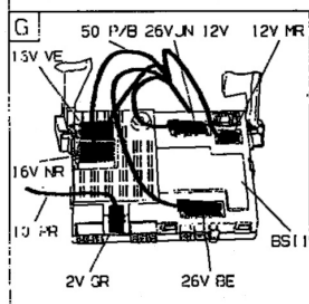
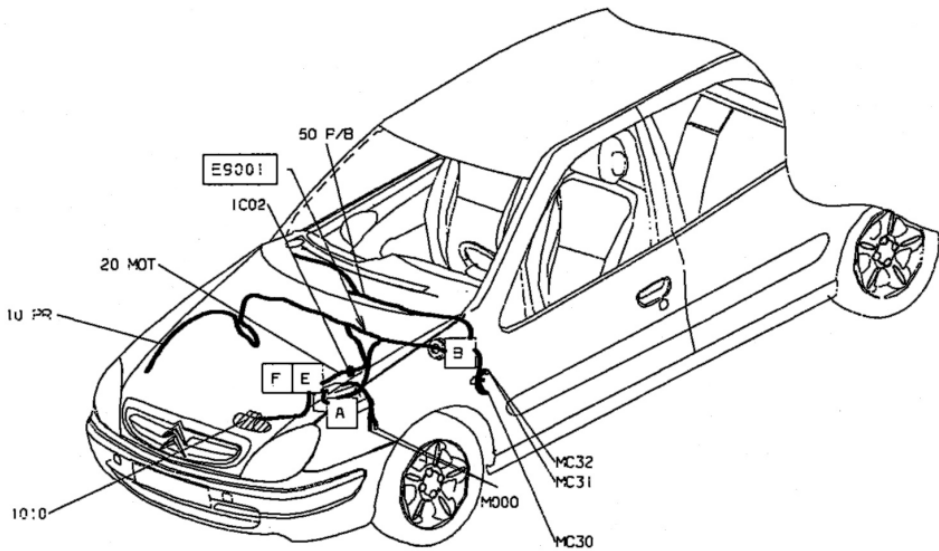

INICIO

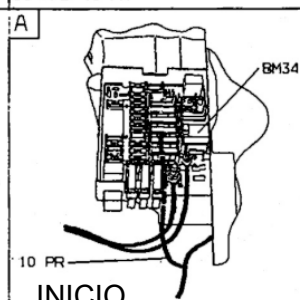
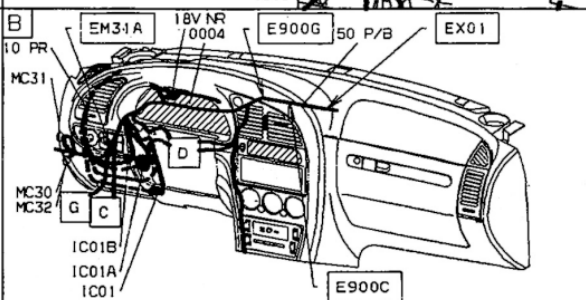
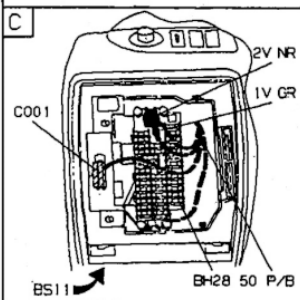
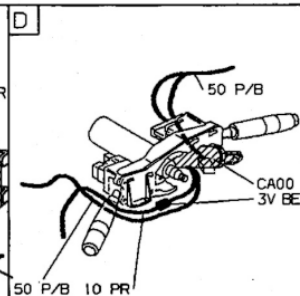
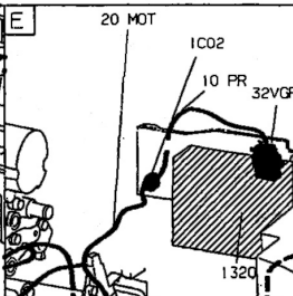
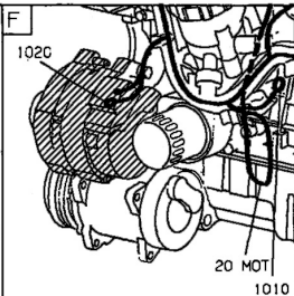
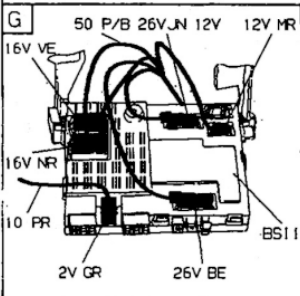
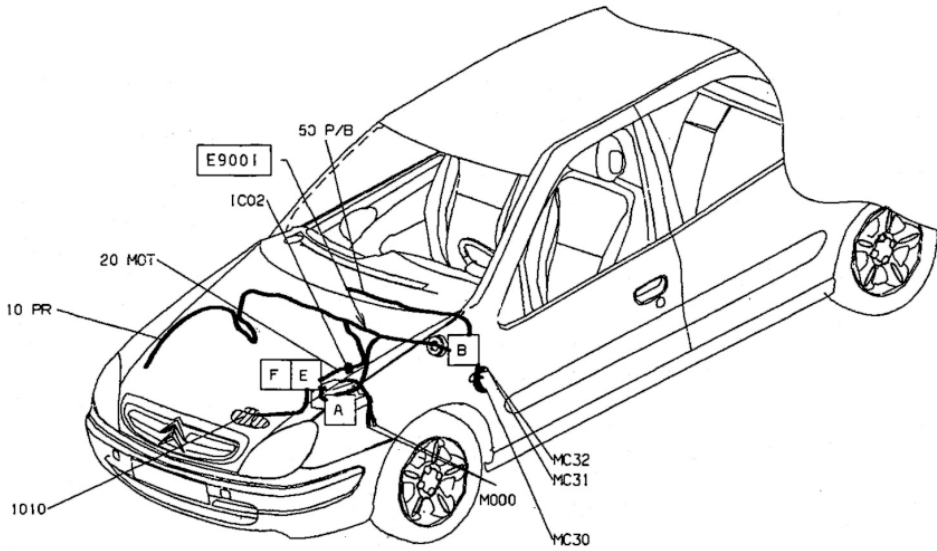

INICIO

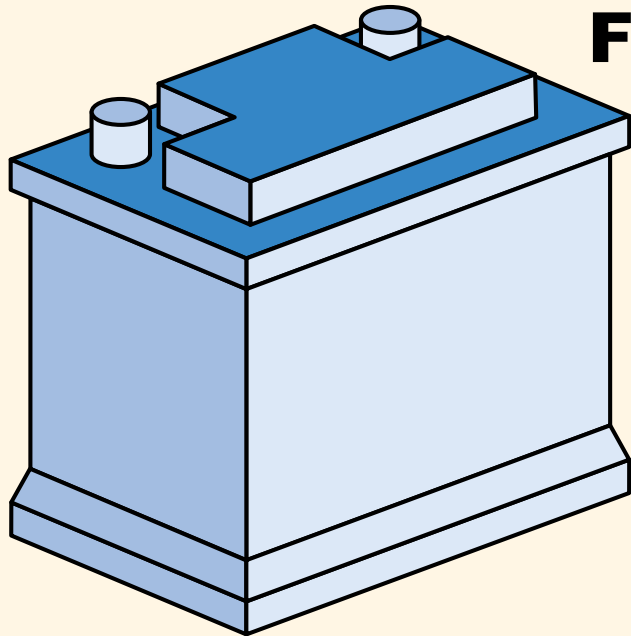

Fusibles

Habitáculo BH28

**Compartimento motor
BM3436**

INICIO

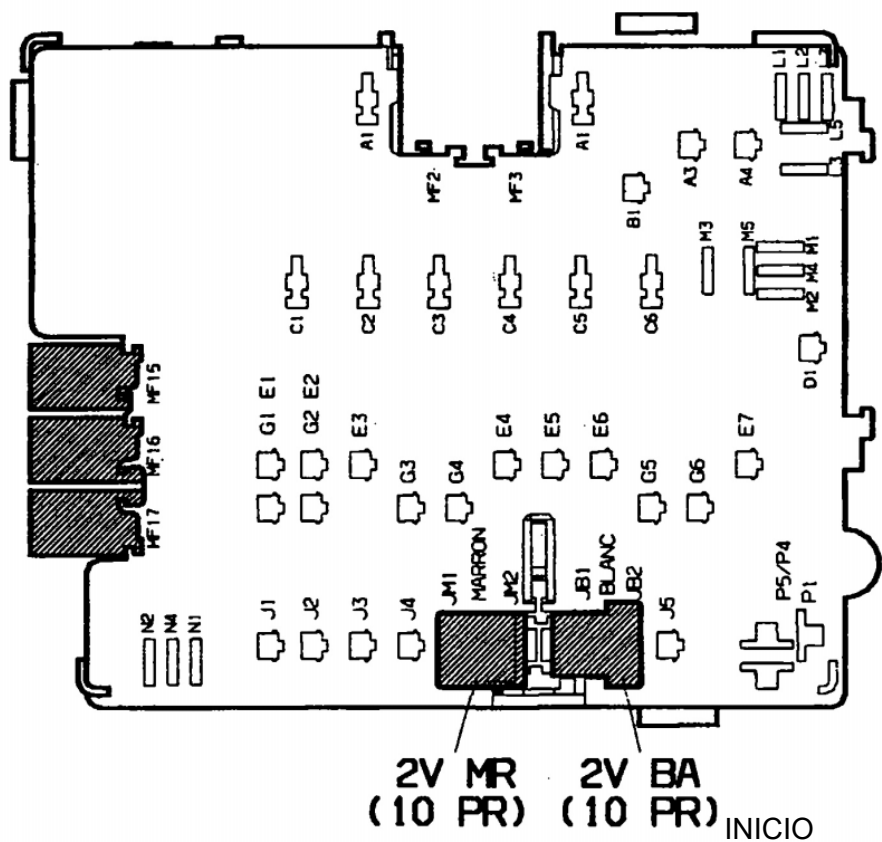
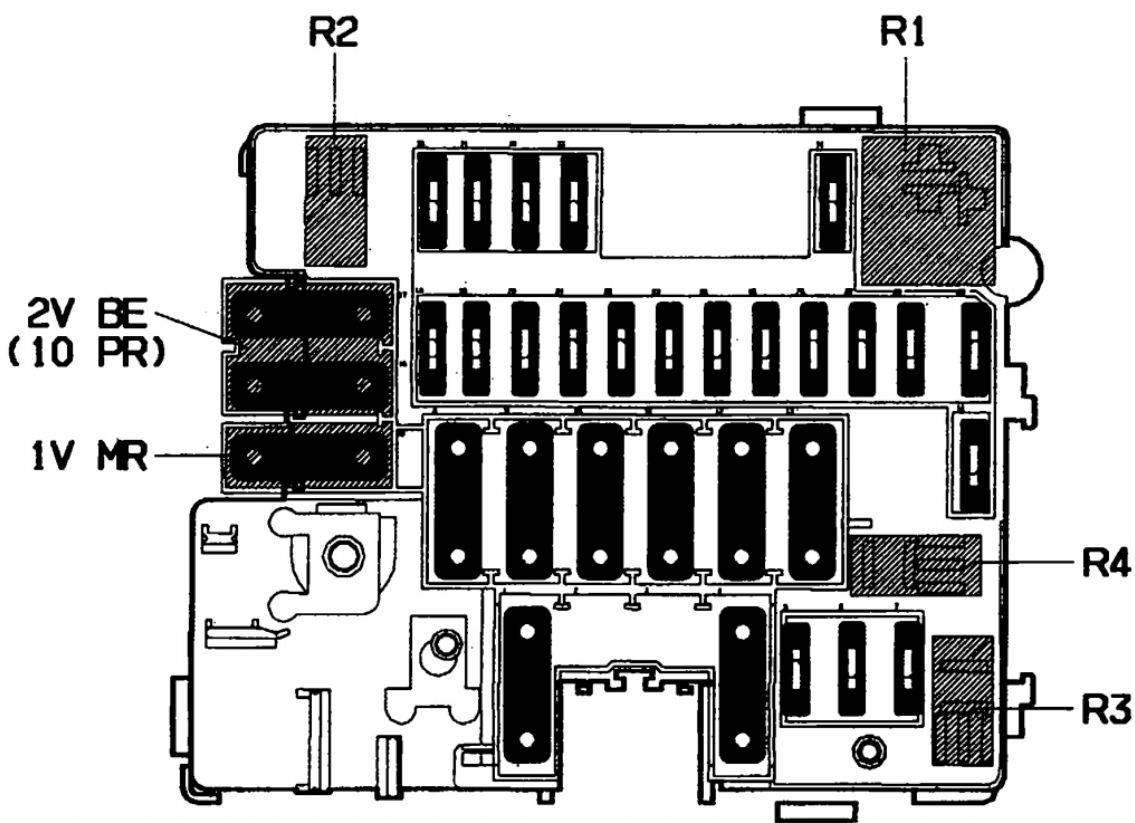

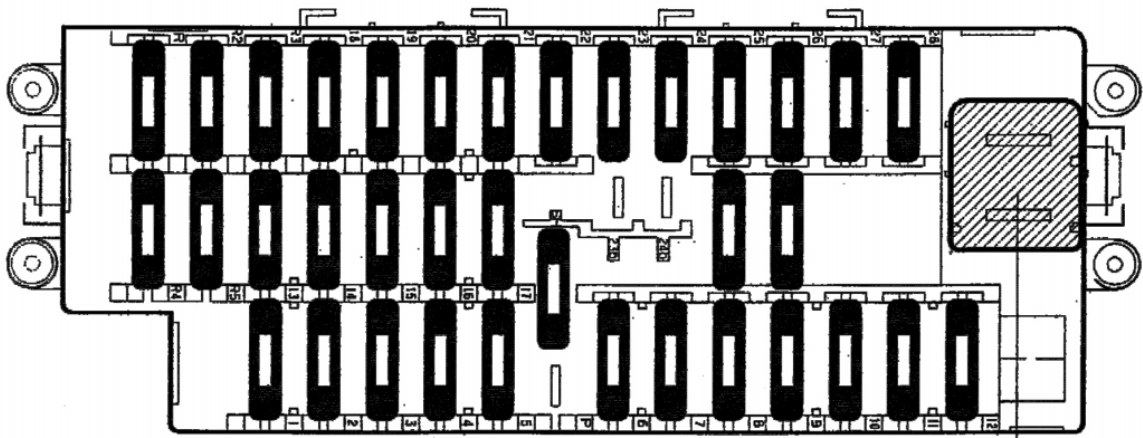

2V BE
(50 P/B)

1V GR
(50 P/B)

(50 P/B)
2V NR

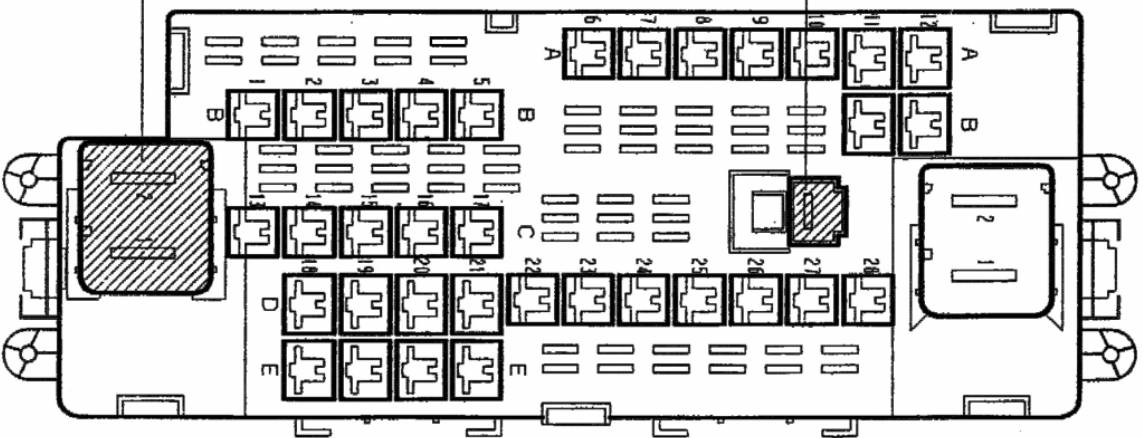

INICIO

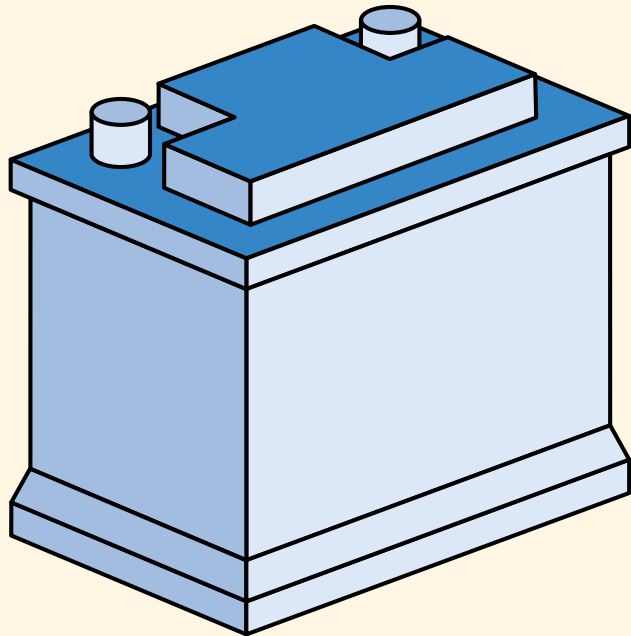

Motor

Habitáculo

INICIO

1

A

B

2

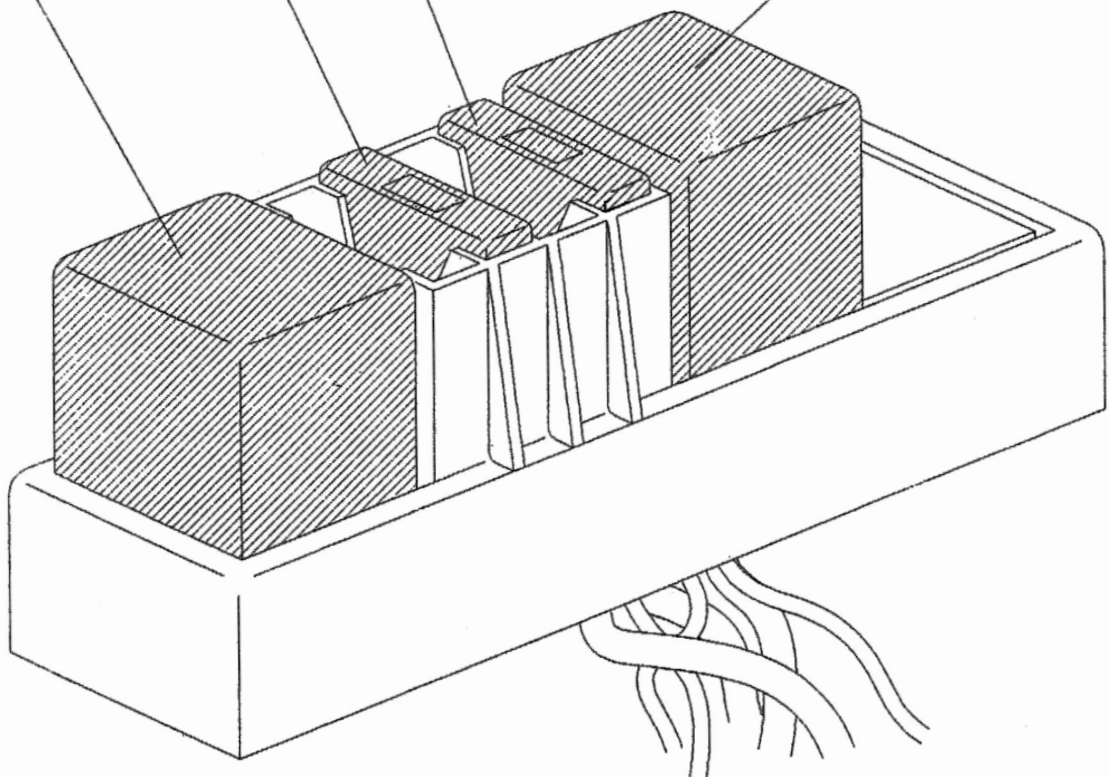

INICIO

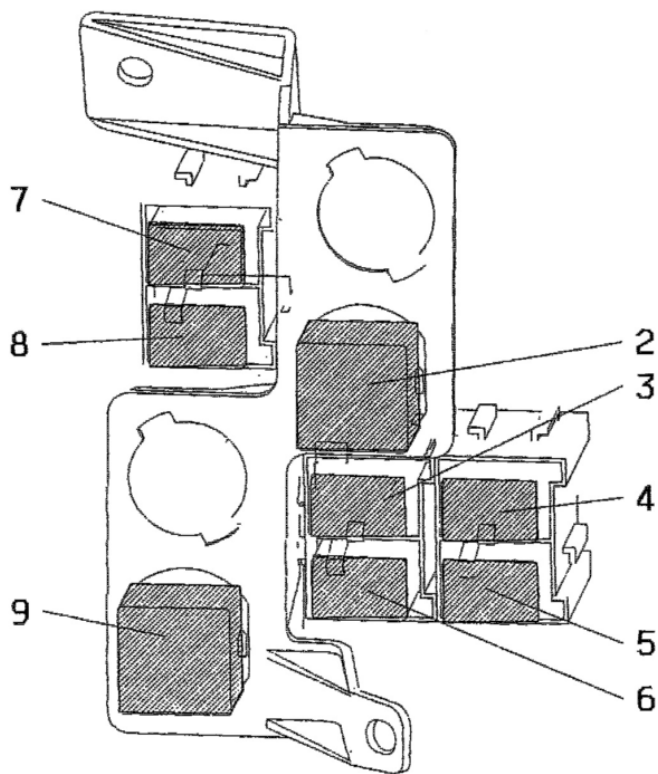
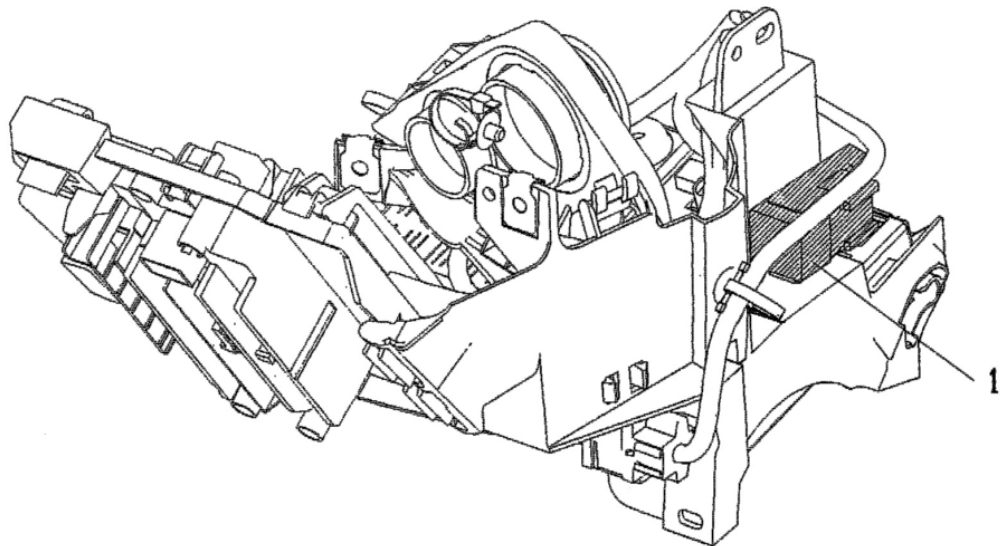

INICIO

Arquitectura electrónica

Conector diagnóstico

BSI

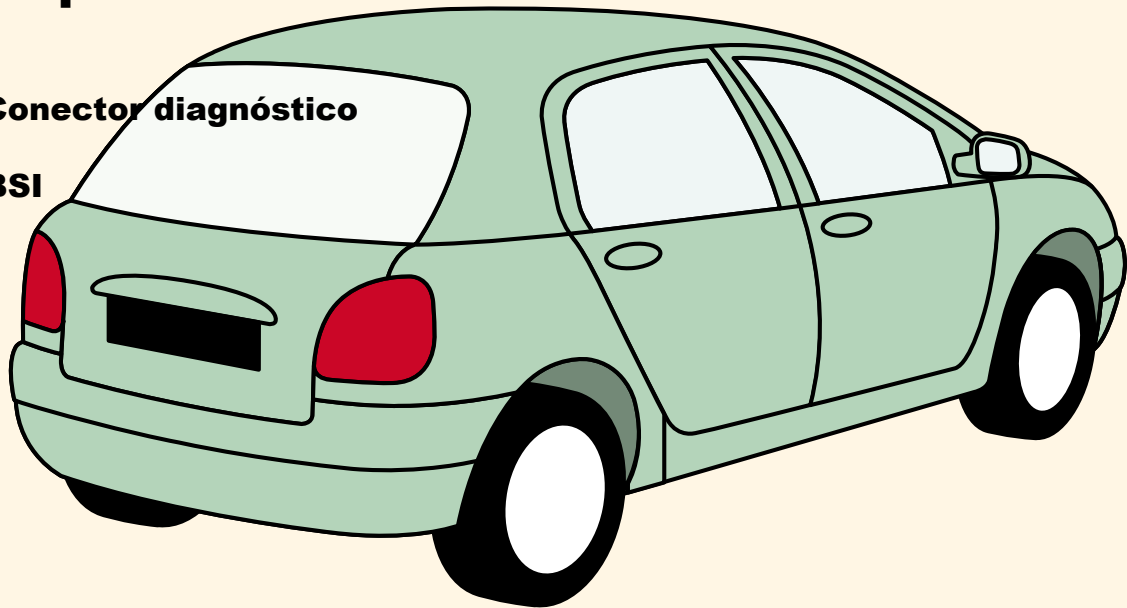

INICIO

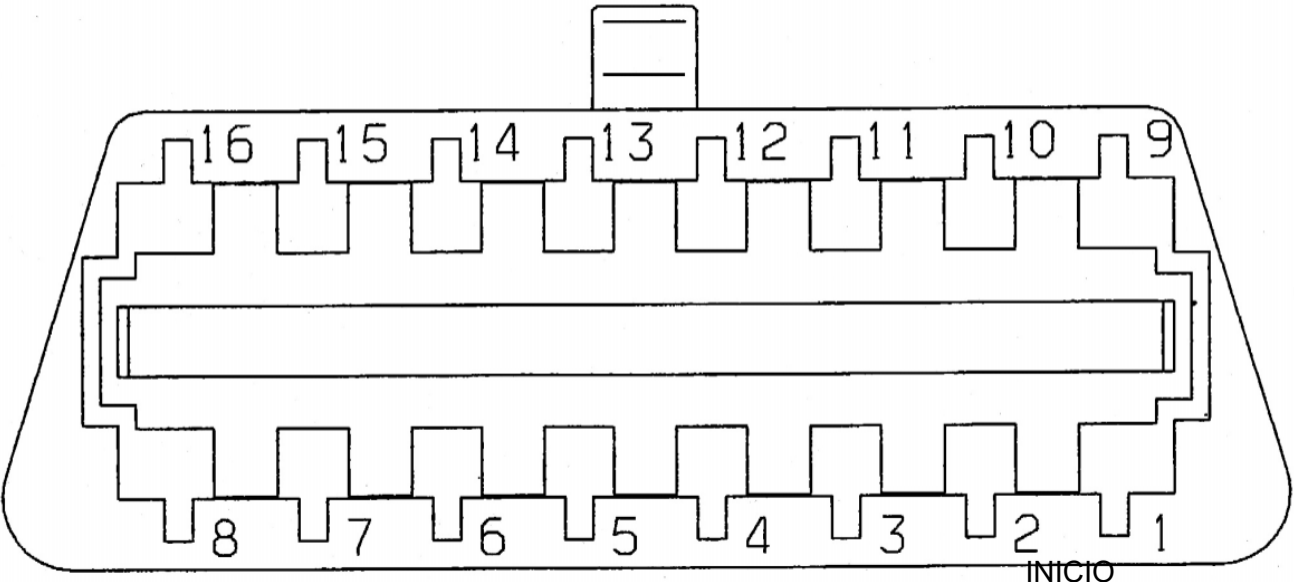

COMIENZO

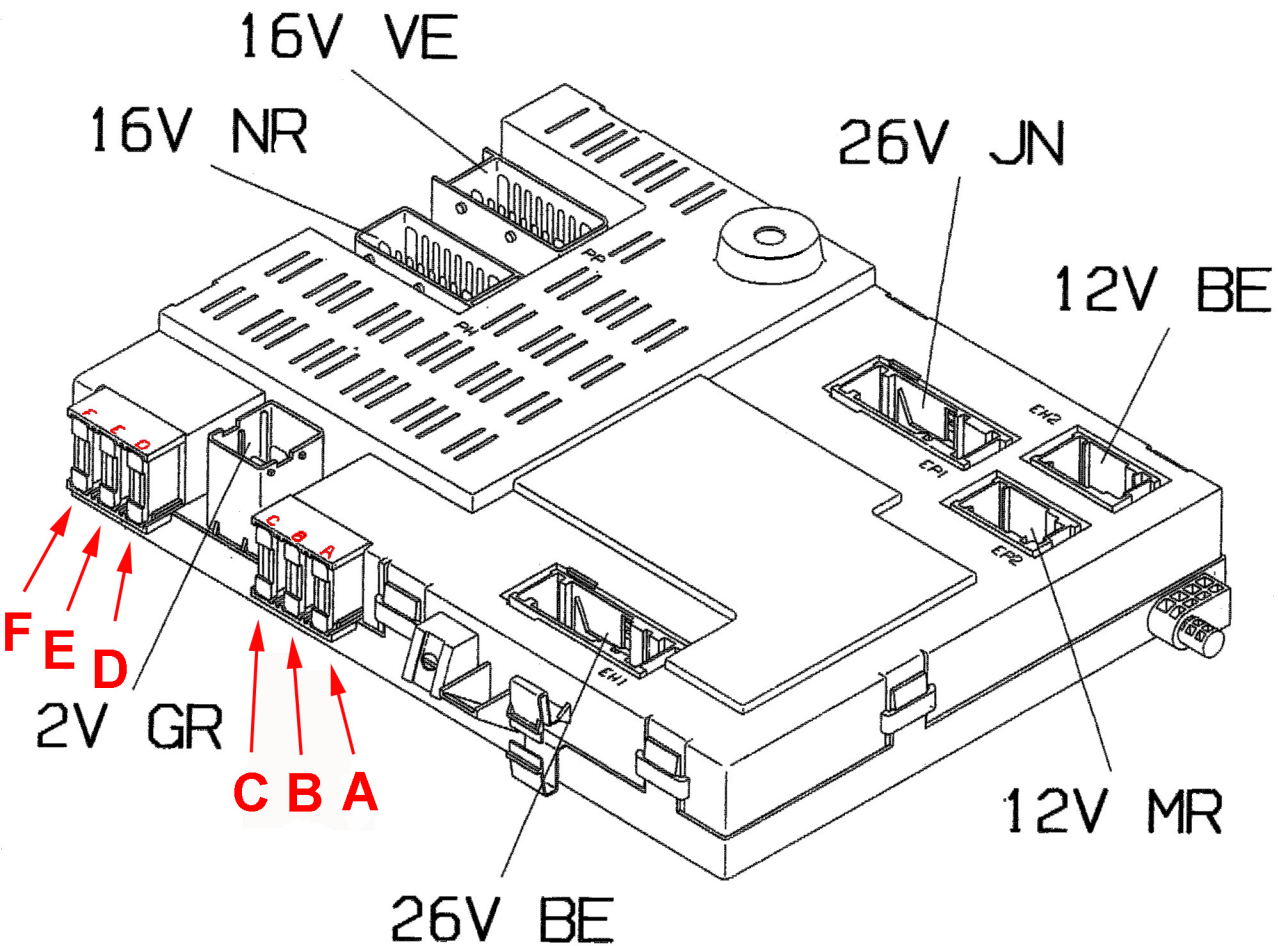

INICIO

Grupo motor propulsor

Gestión motor

Refrigeración

Caixa cambios automática

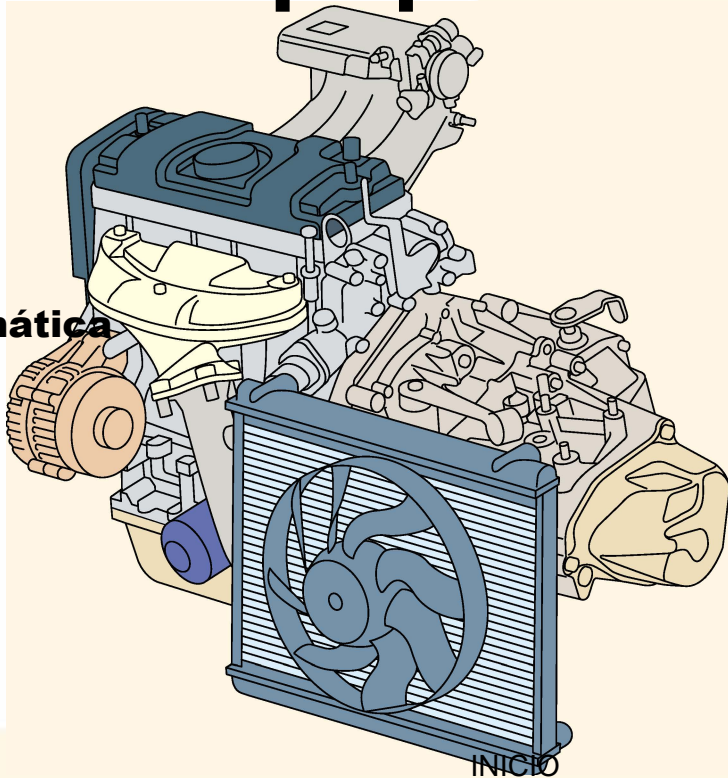

Xestión motor

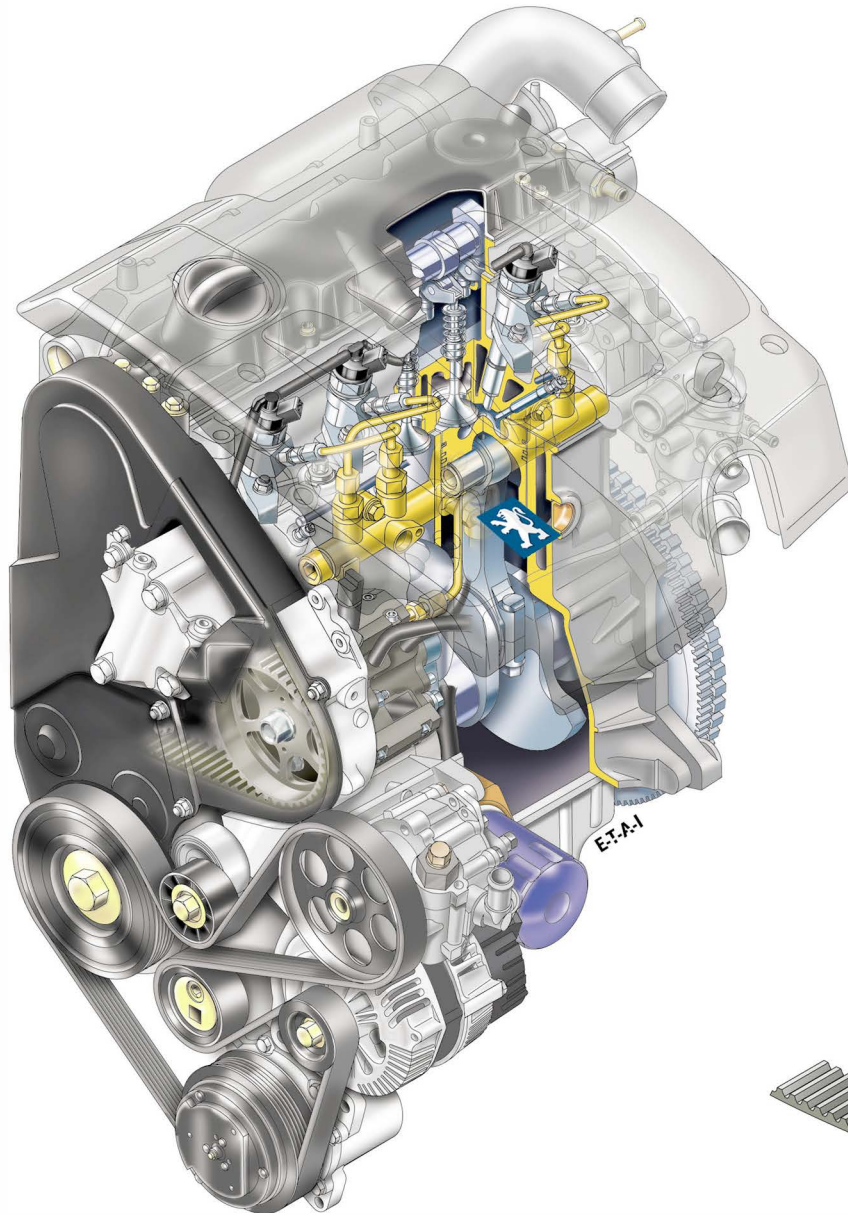

Prequentamento



Inxección

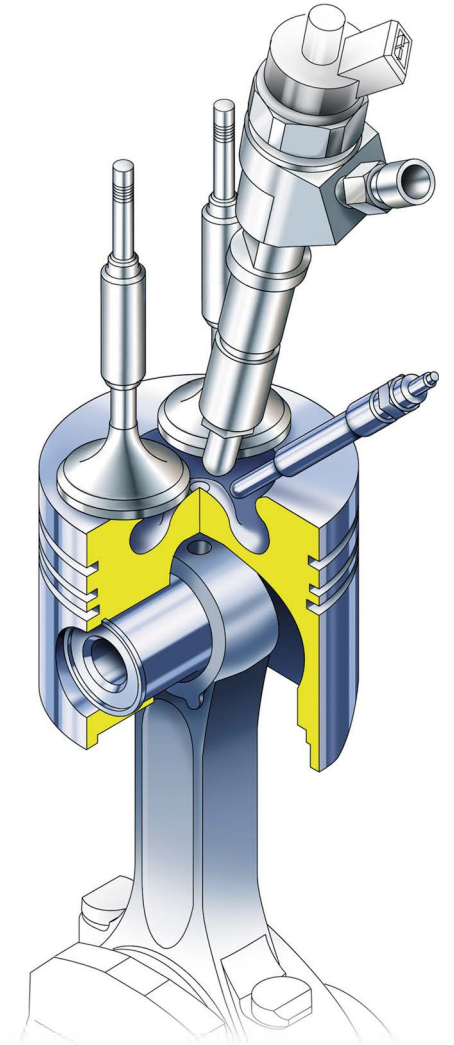
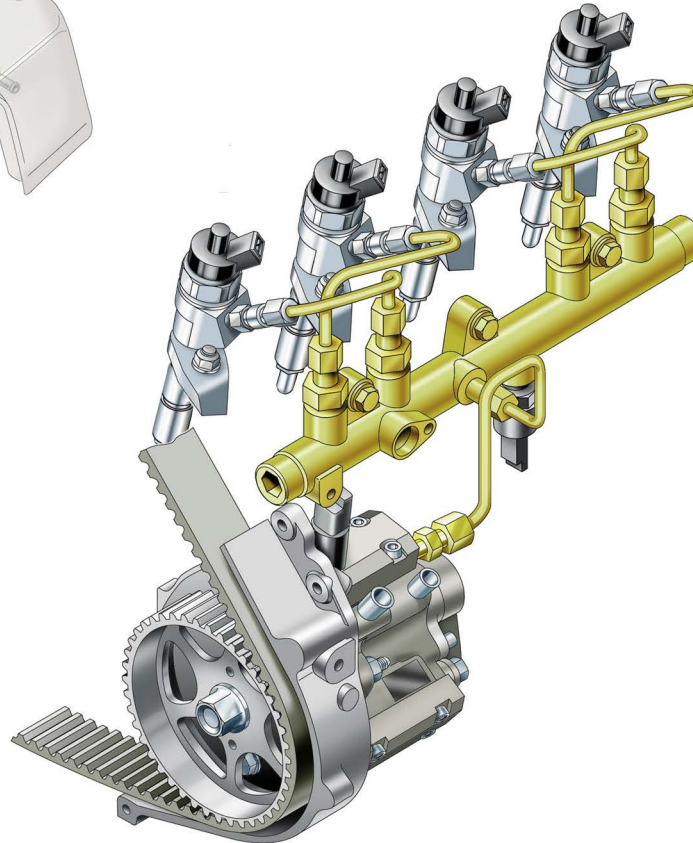

Preaquecimento

Con caixa manual

Con caixa automática

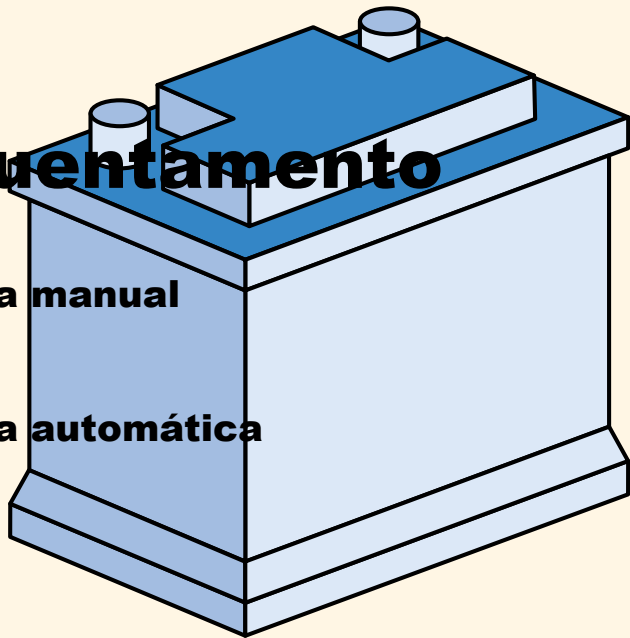

INICIO

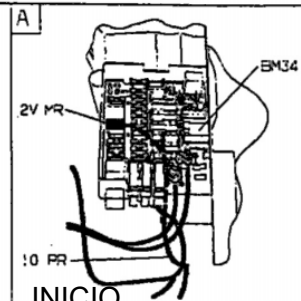
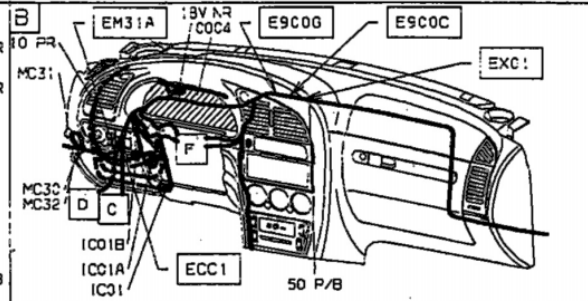
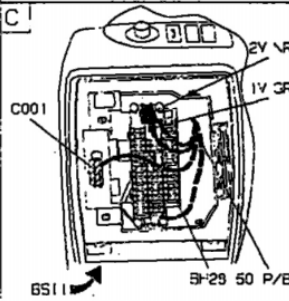
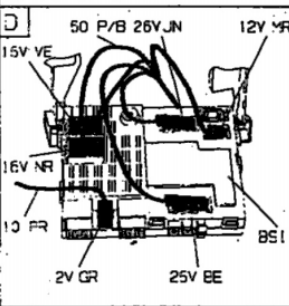
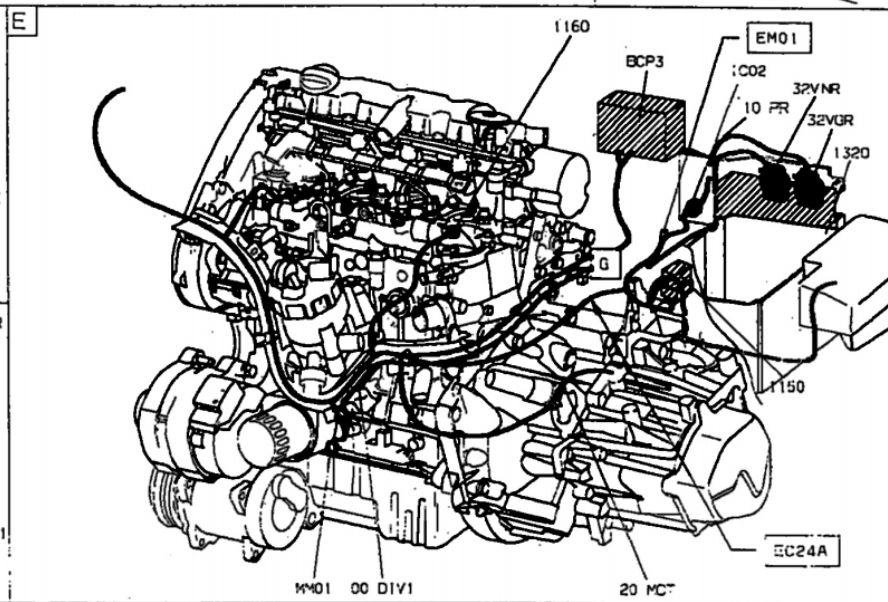
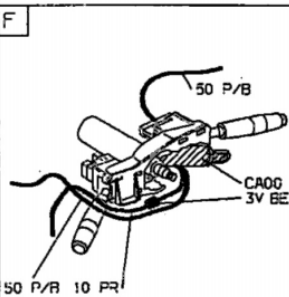
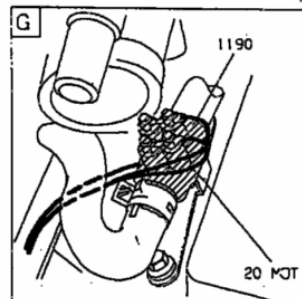
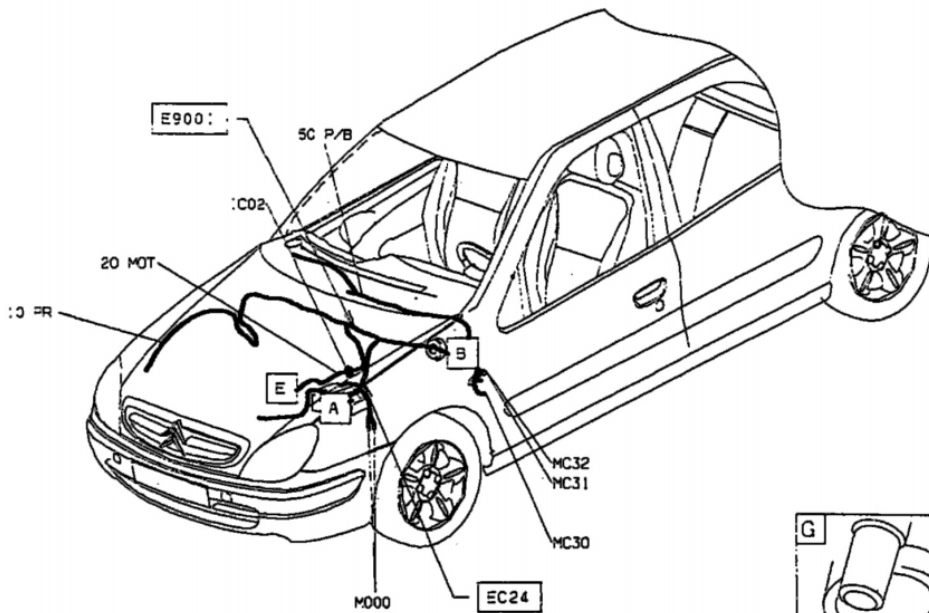

INICIO

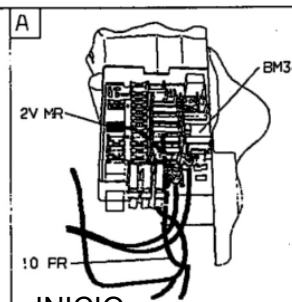
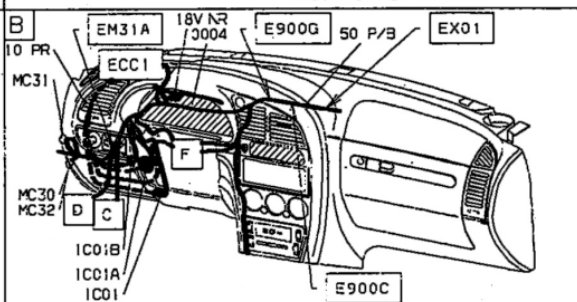
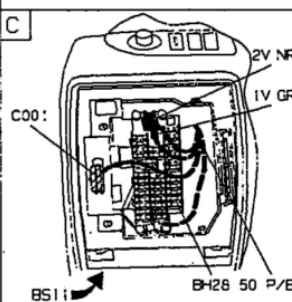
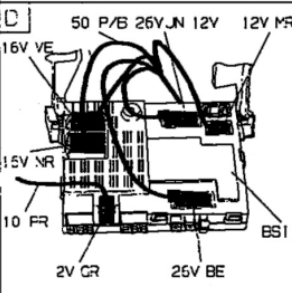
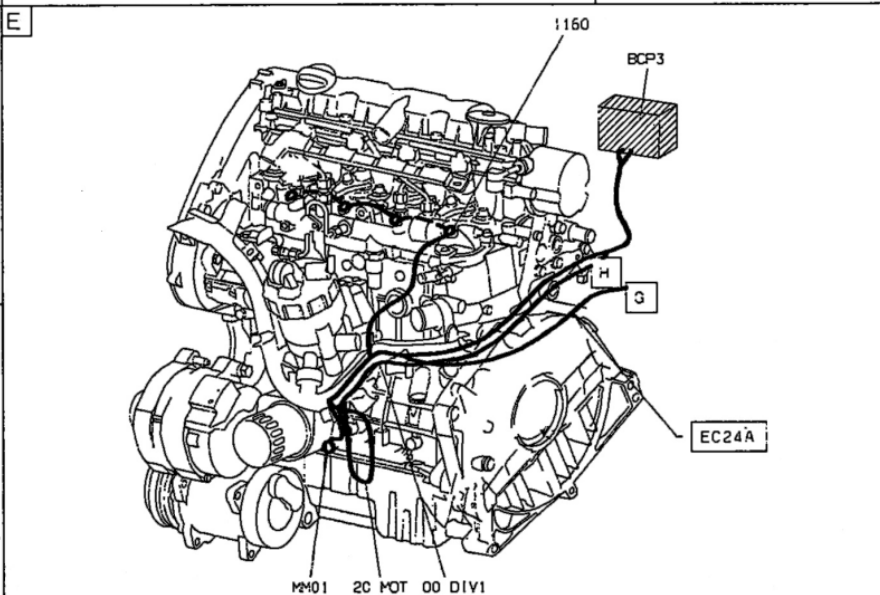
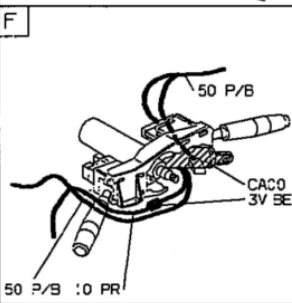
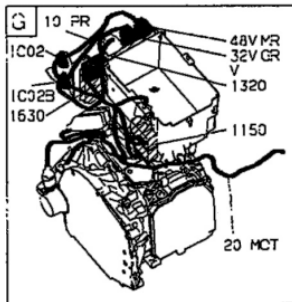
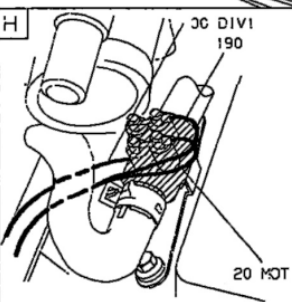
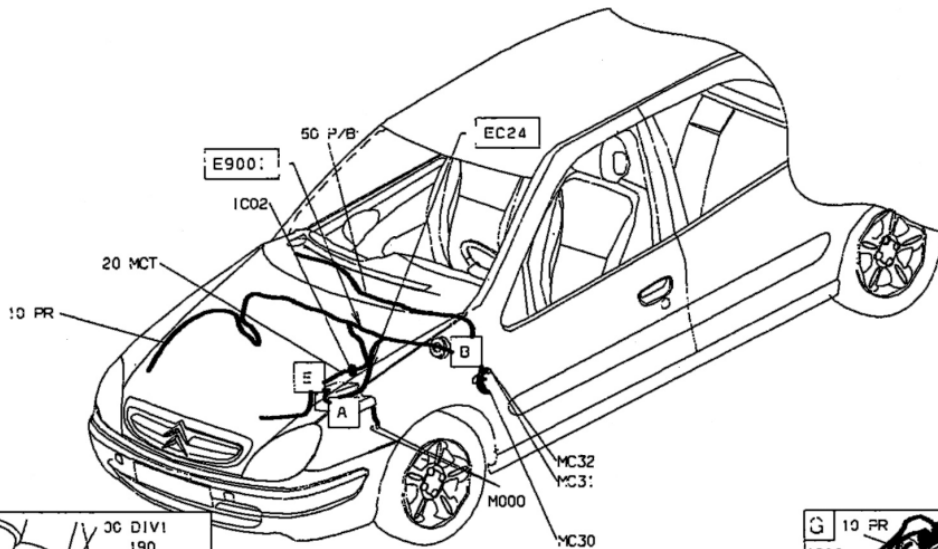

INICIO

Inyección

Motor RHY

Motor RHZ

Motor RHZ con caixa automática

E.T.A.I

INICIO

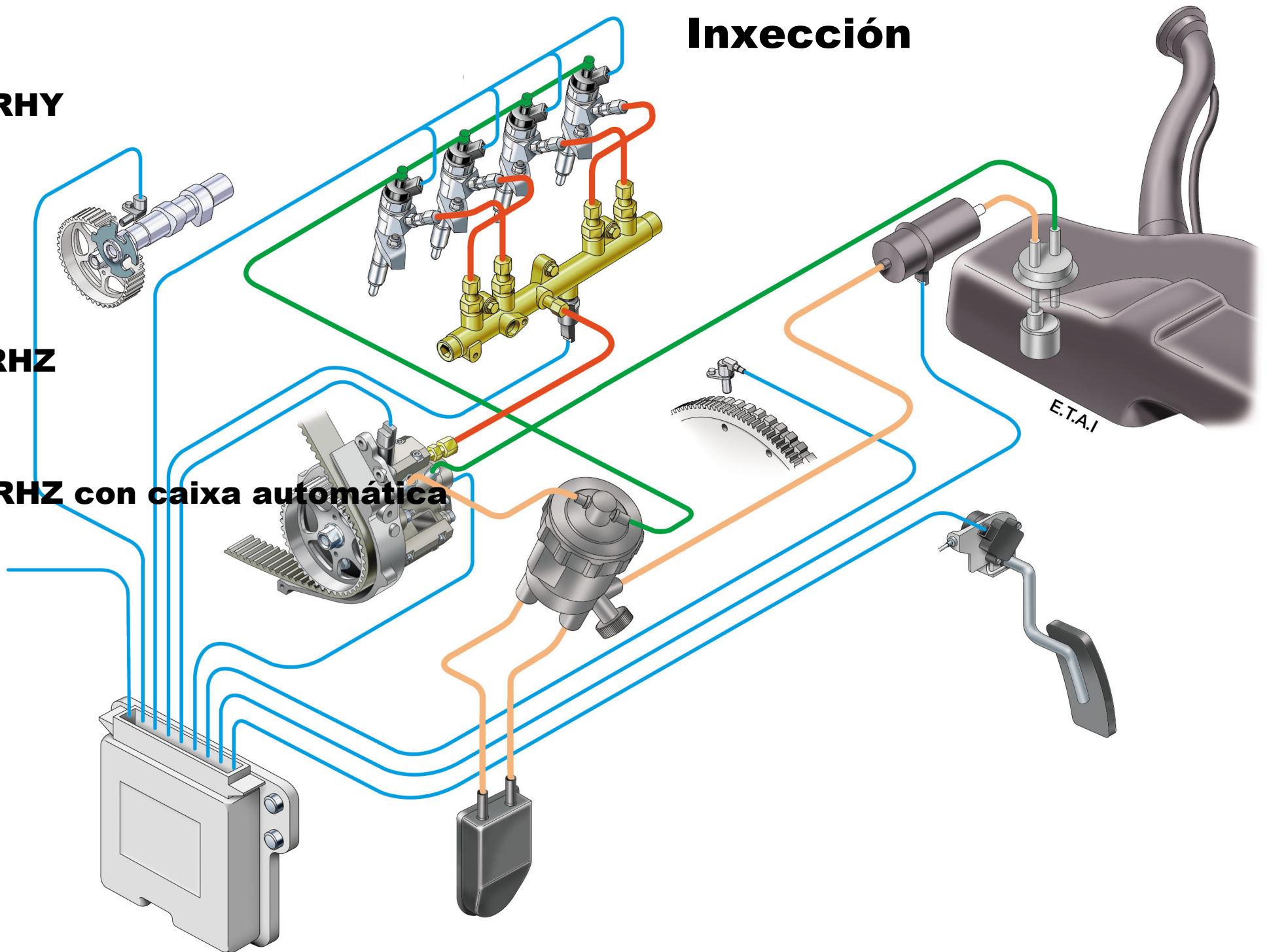

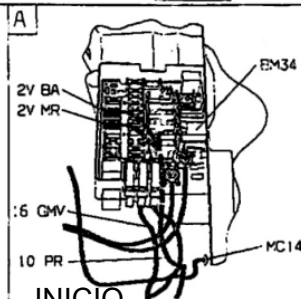
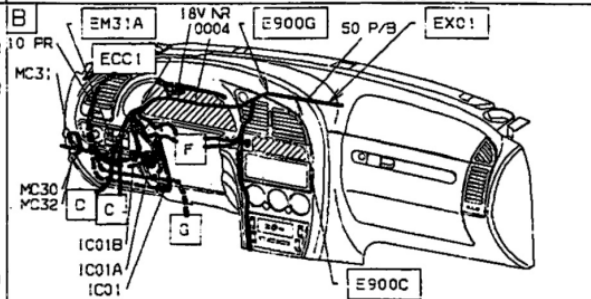
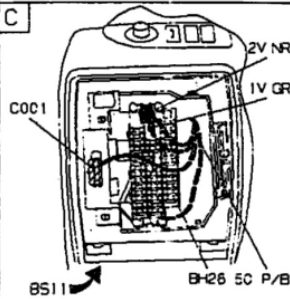
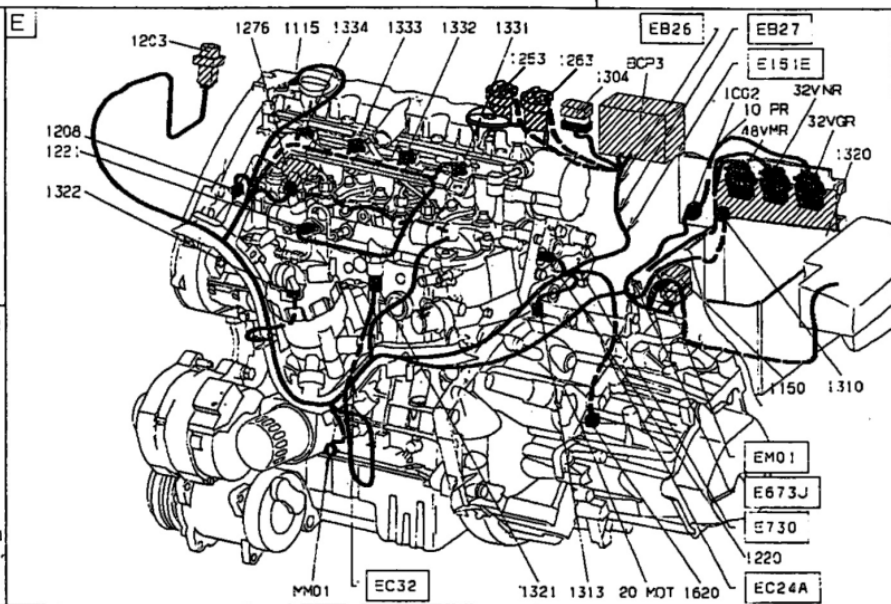
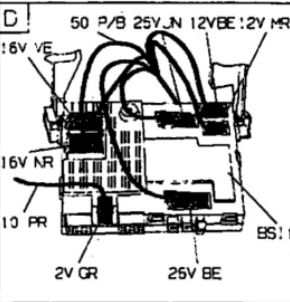
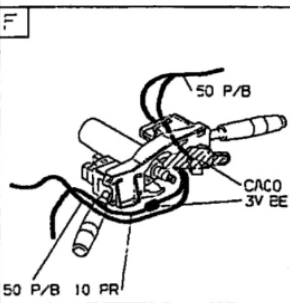
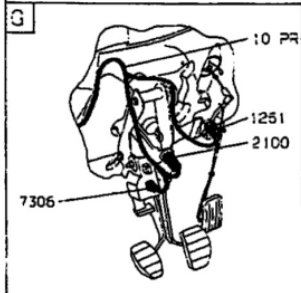
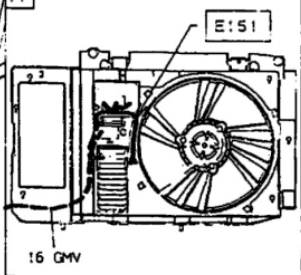
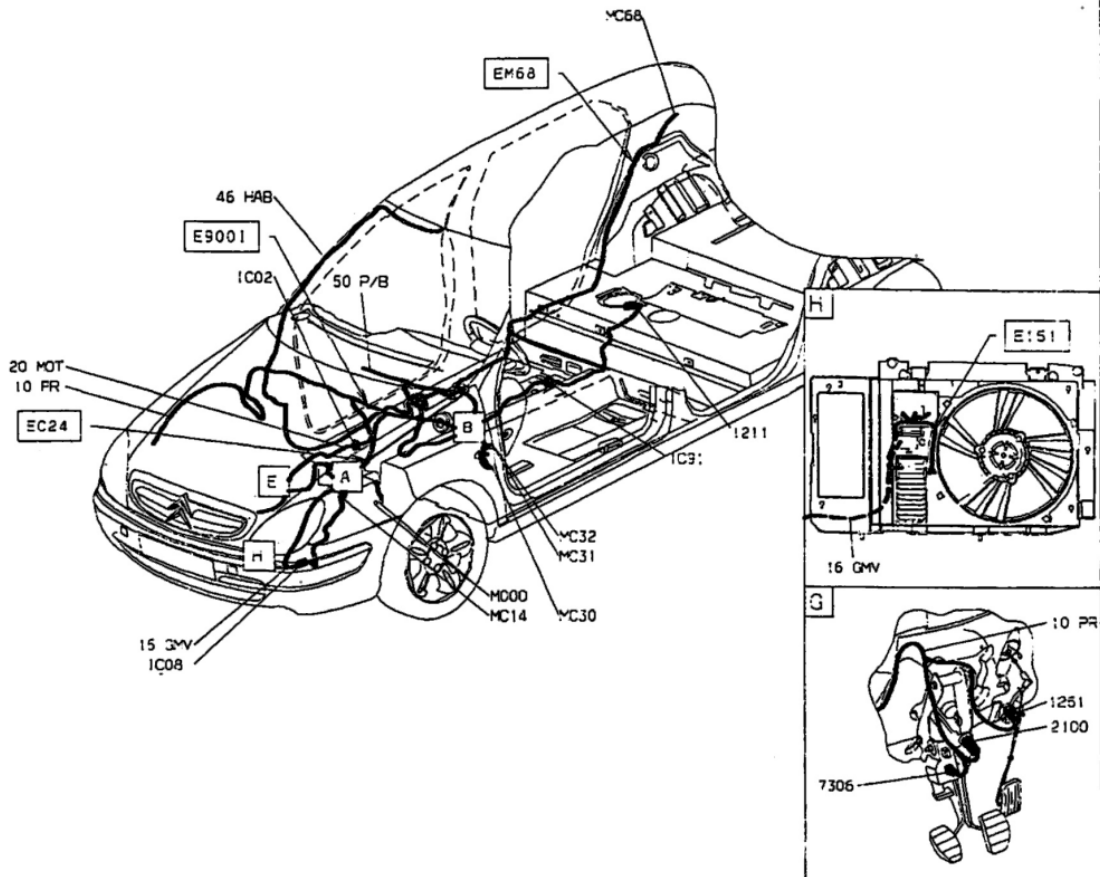

INICIO

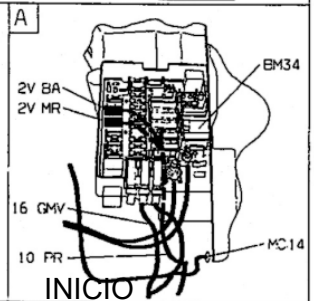
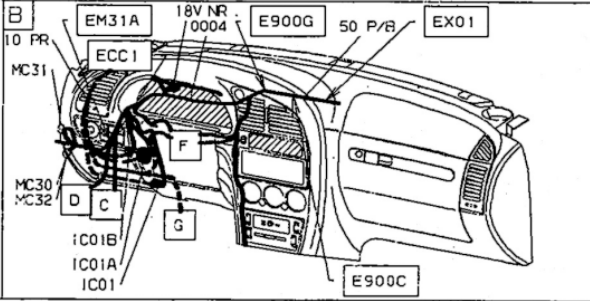
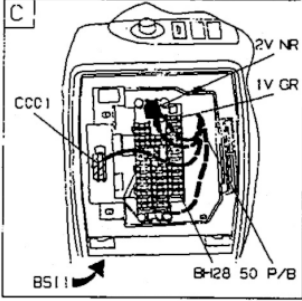
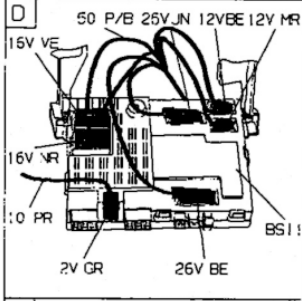
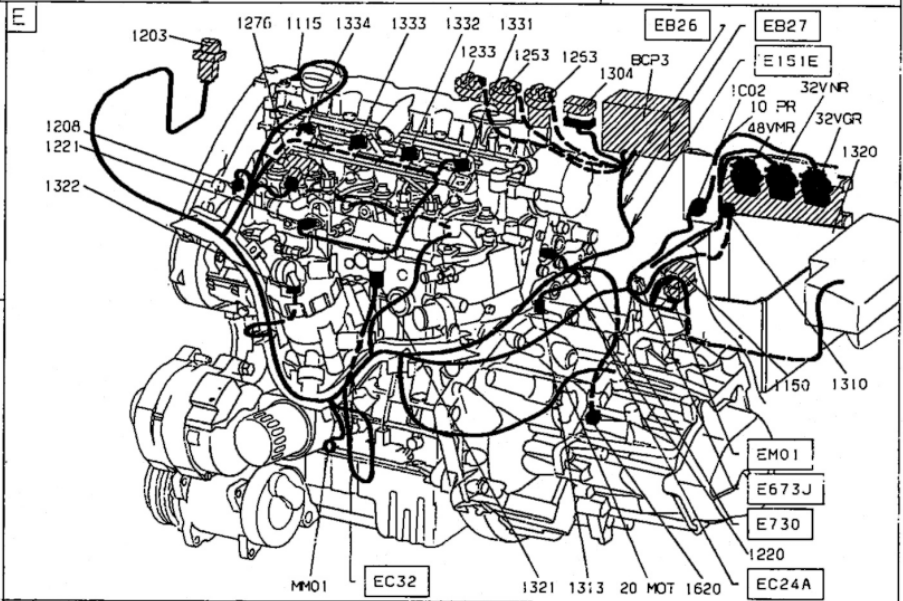
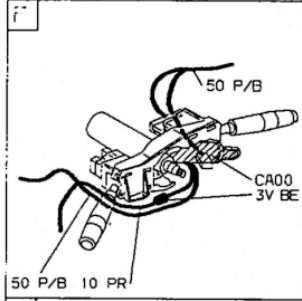
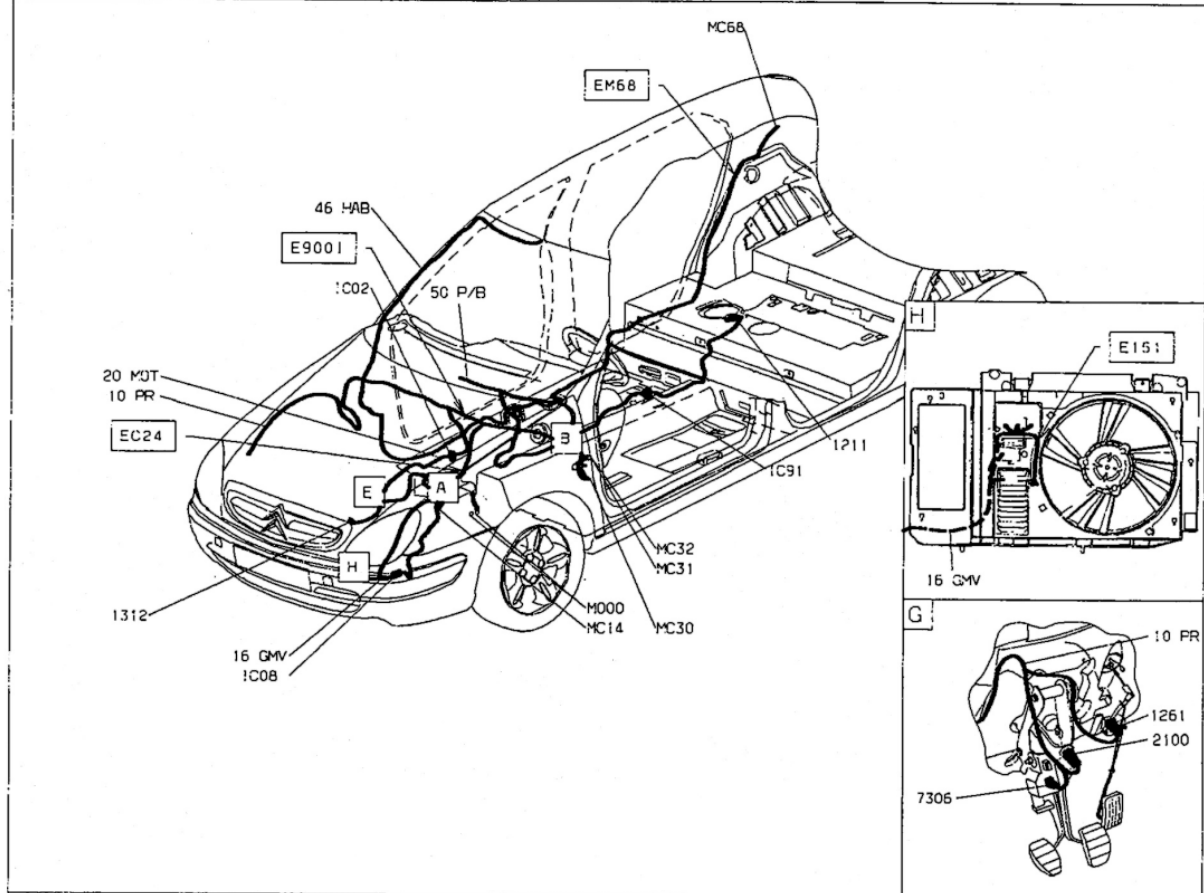

INICIO

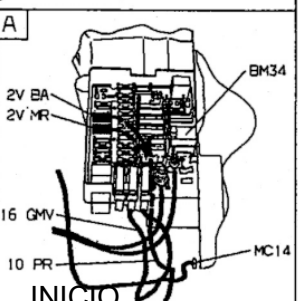
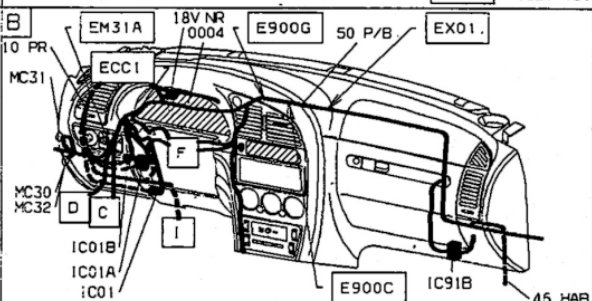
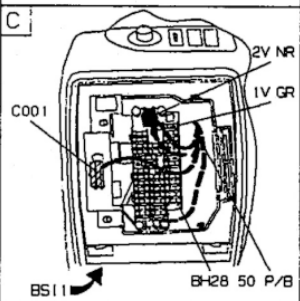
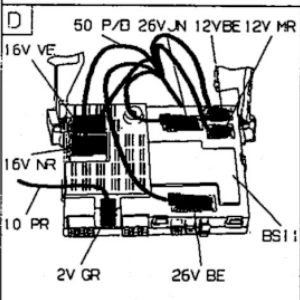
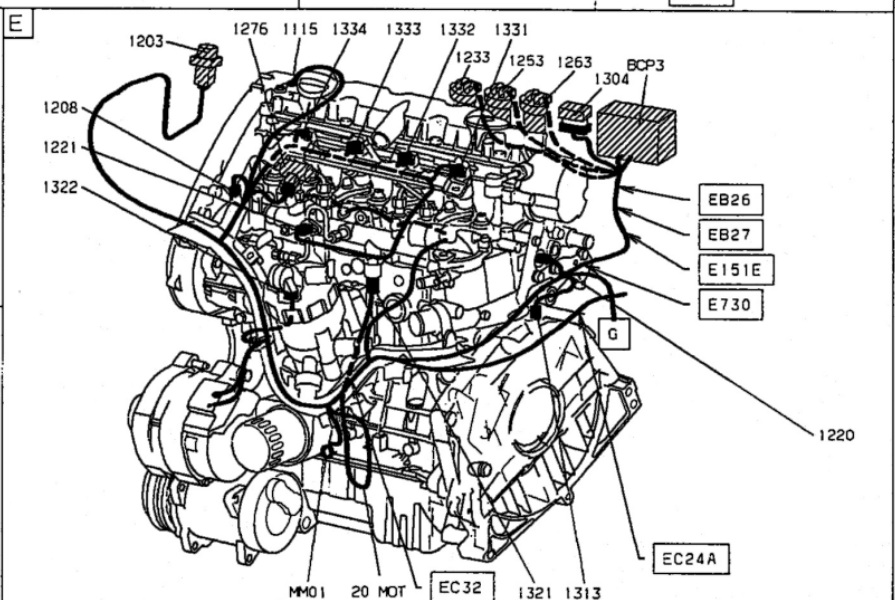
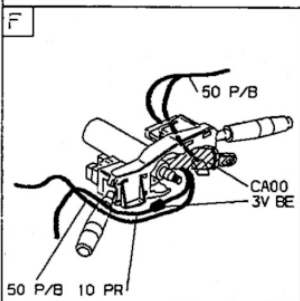
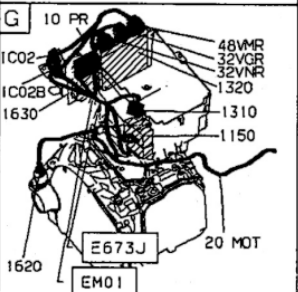
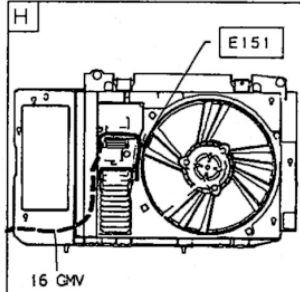
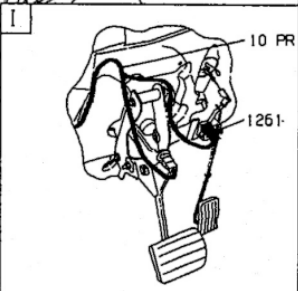
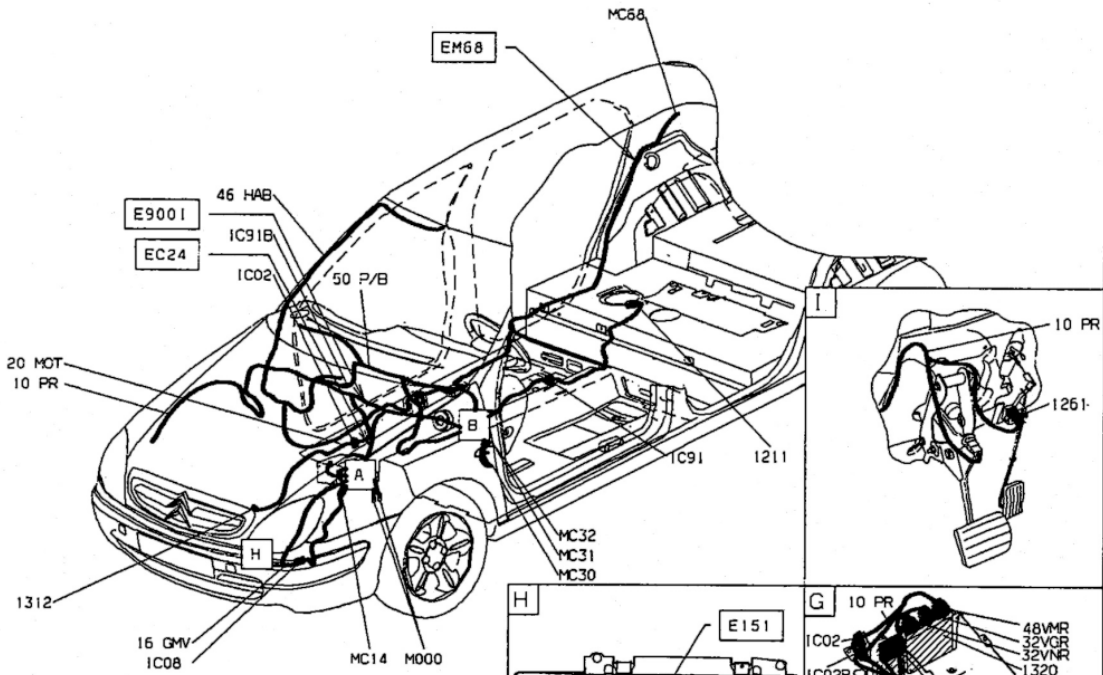

INICIO

Refrixeración

Motor sin climatización

Motor con climatización

Motor con climatización e caixa automática

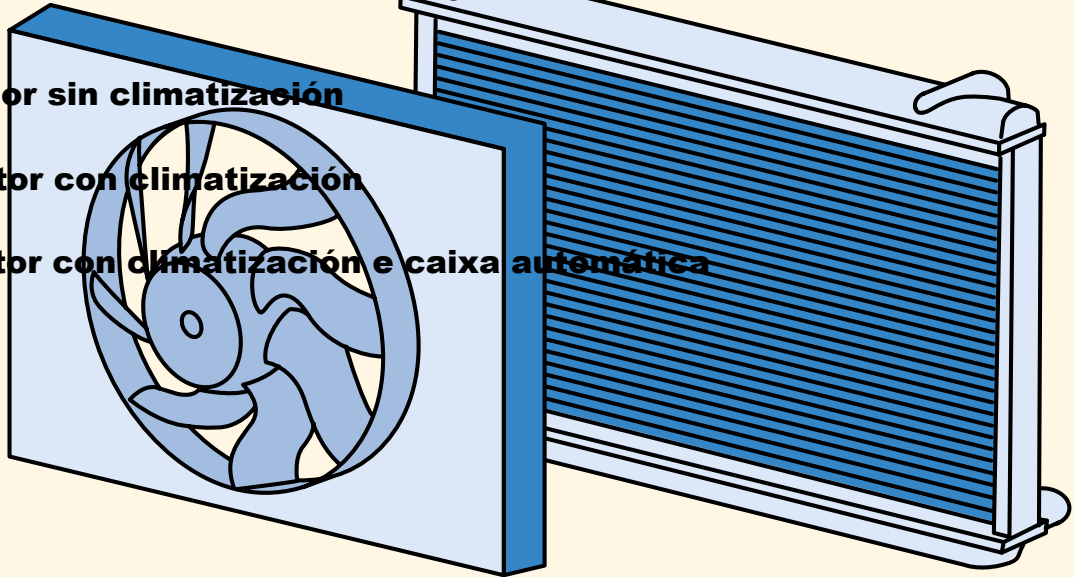

INICIO

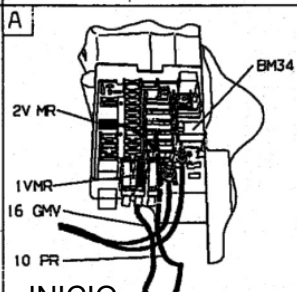
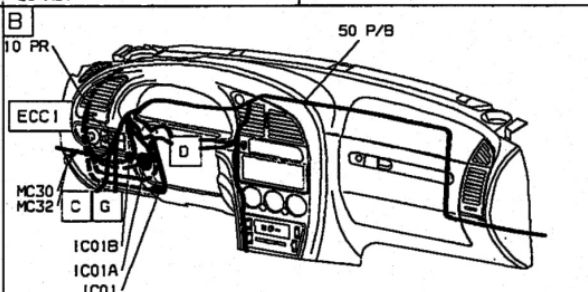
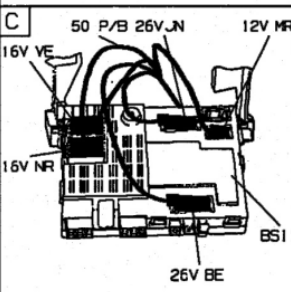
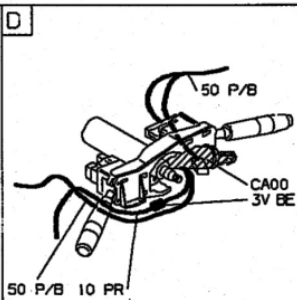
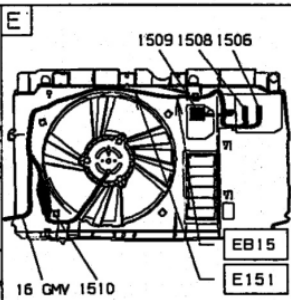
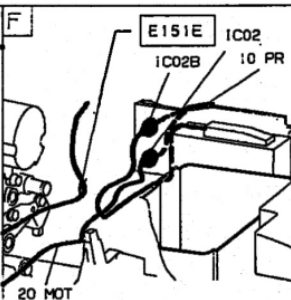
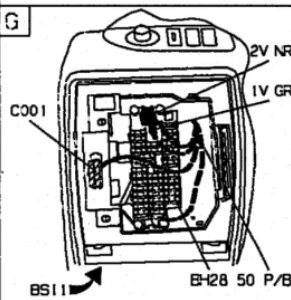
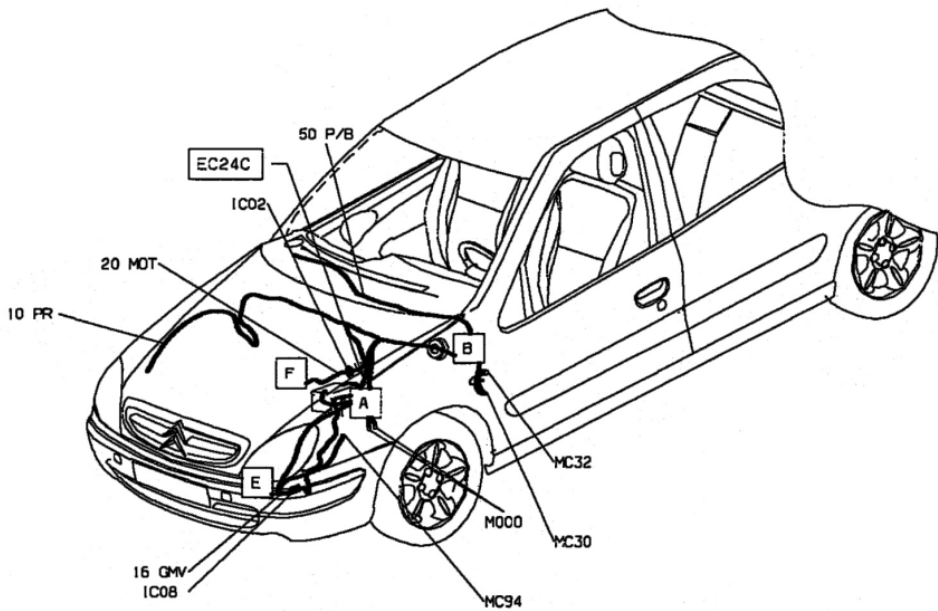

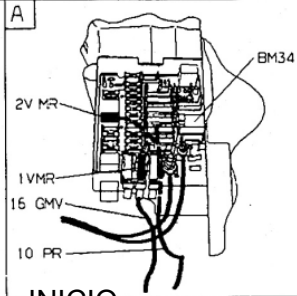
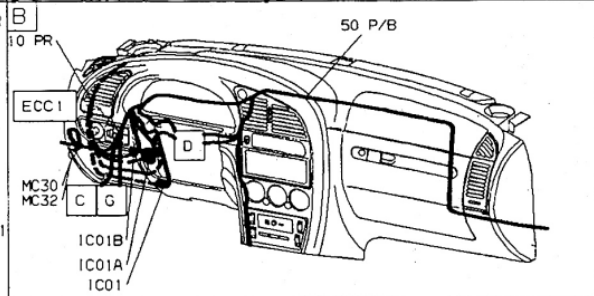
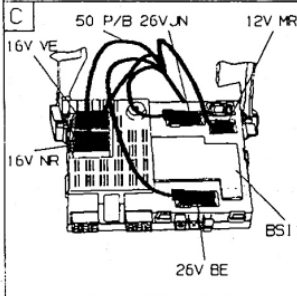
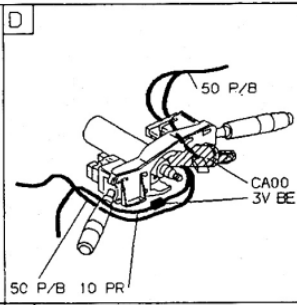
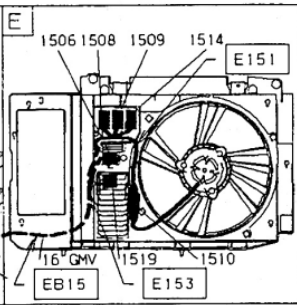
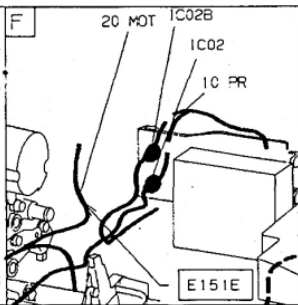
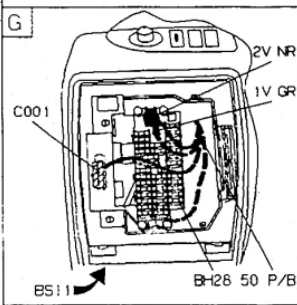
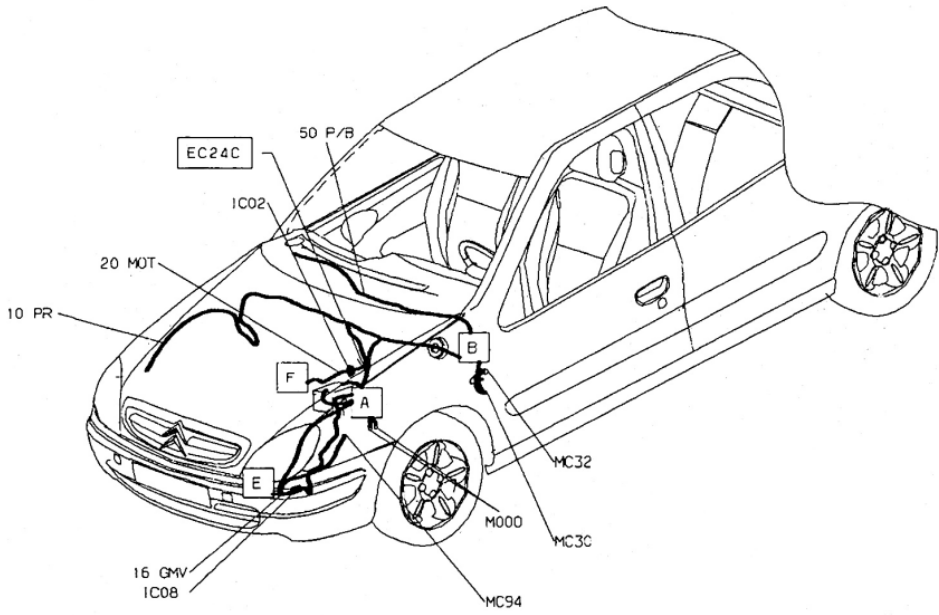

INICIO

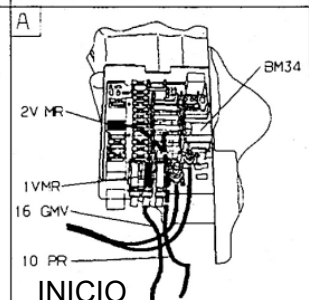
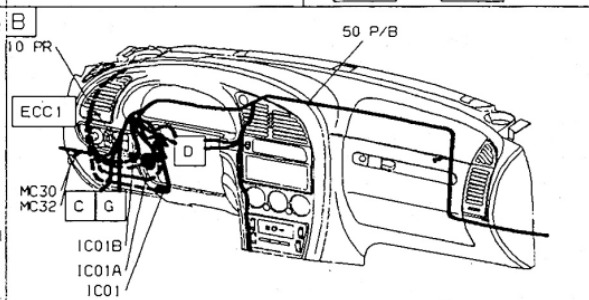
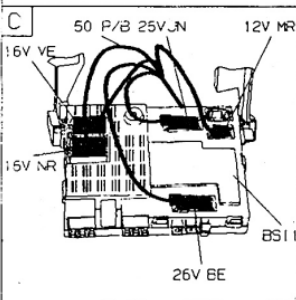
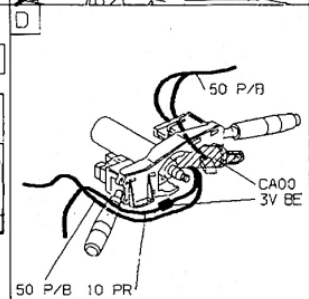
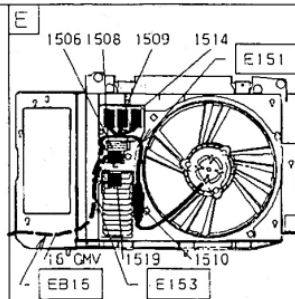
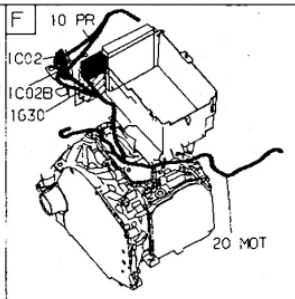
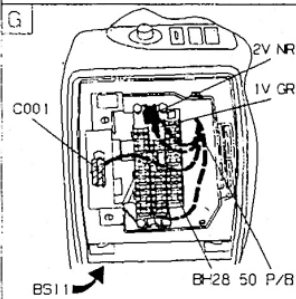
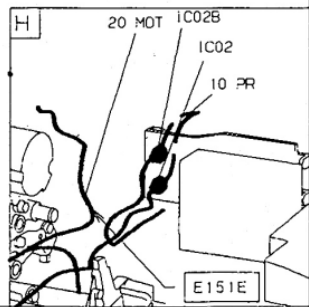
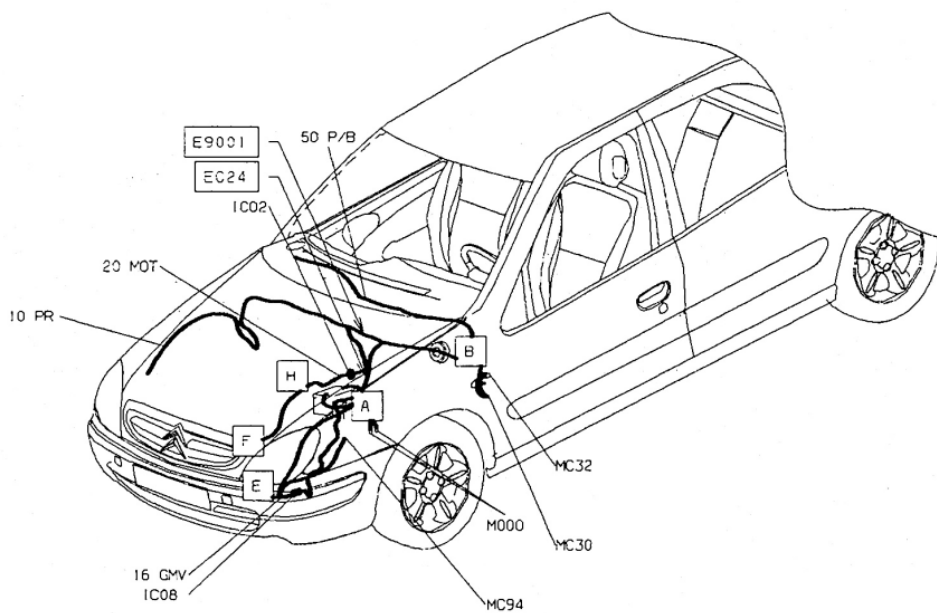

INICIO

Caixa velocidades automática

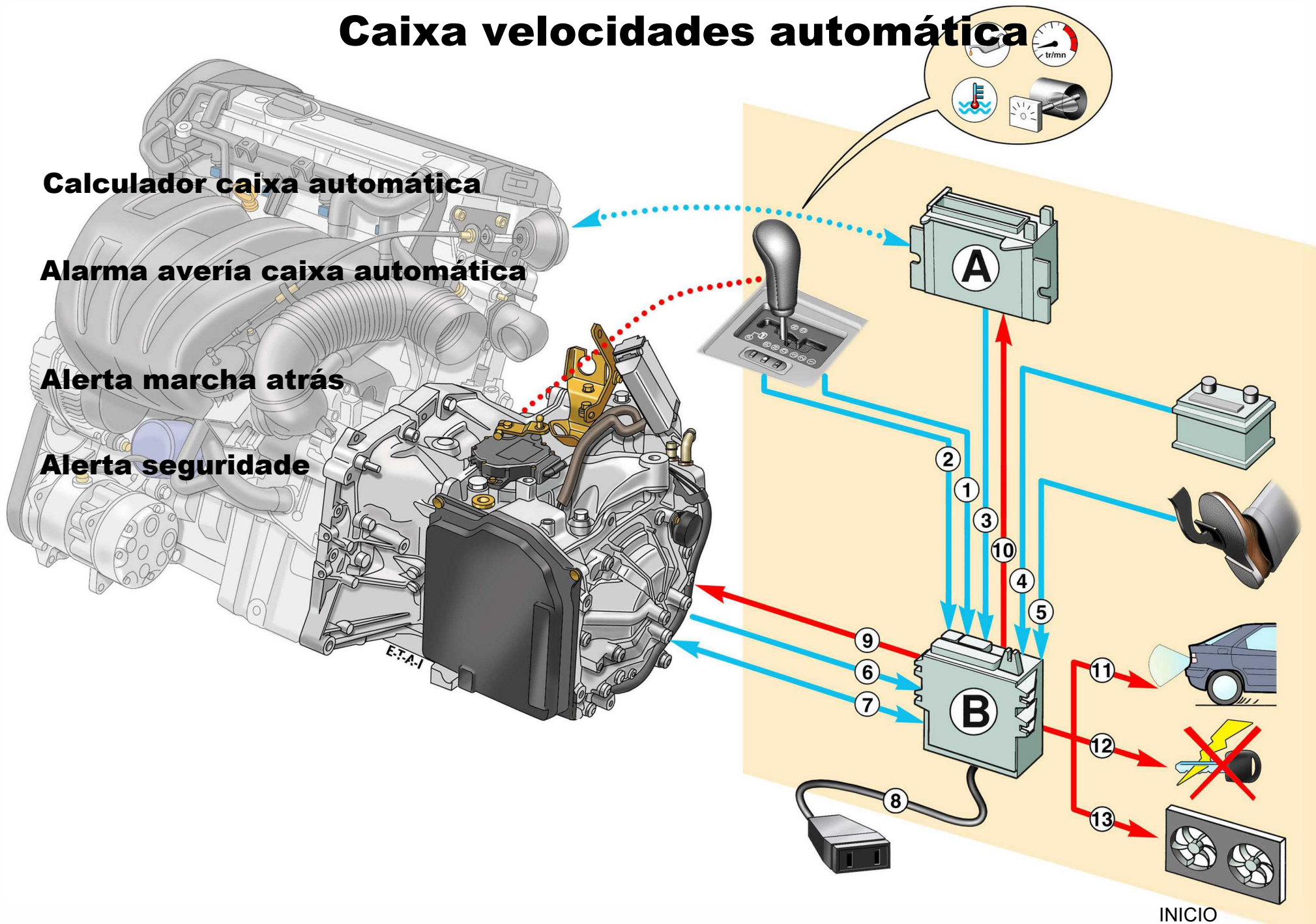

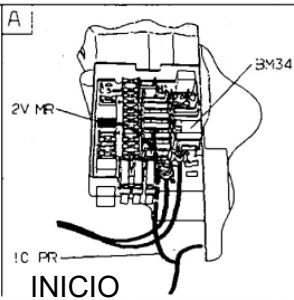
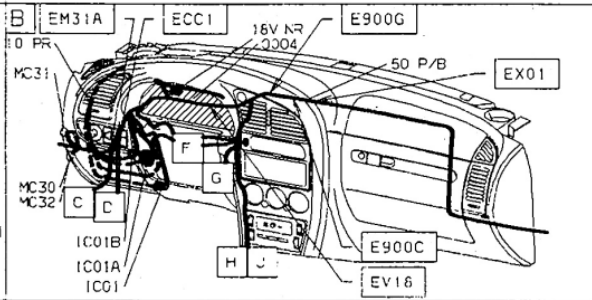
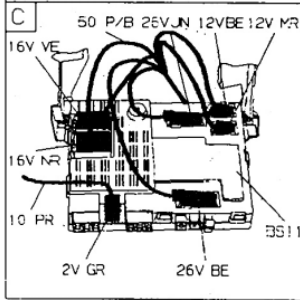
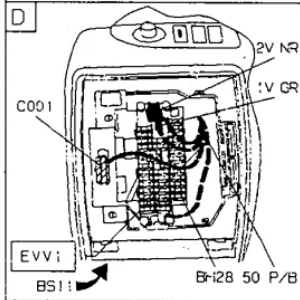
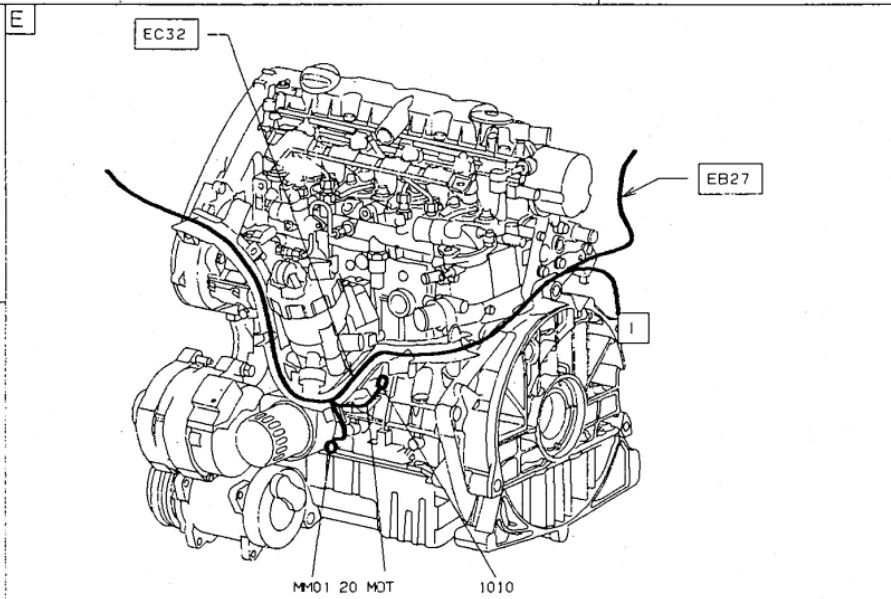
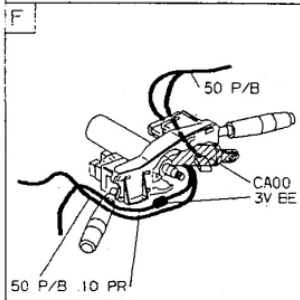
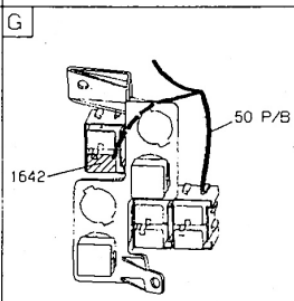
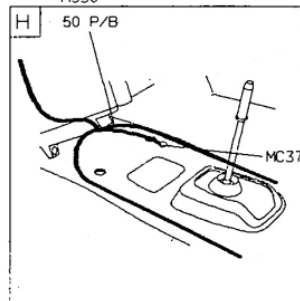
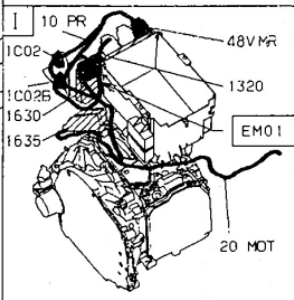
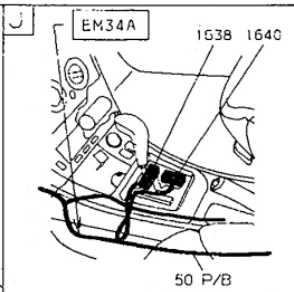
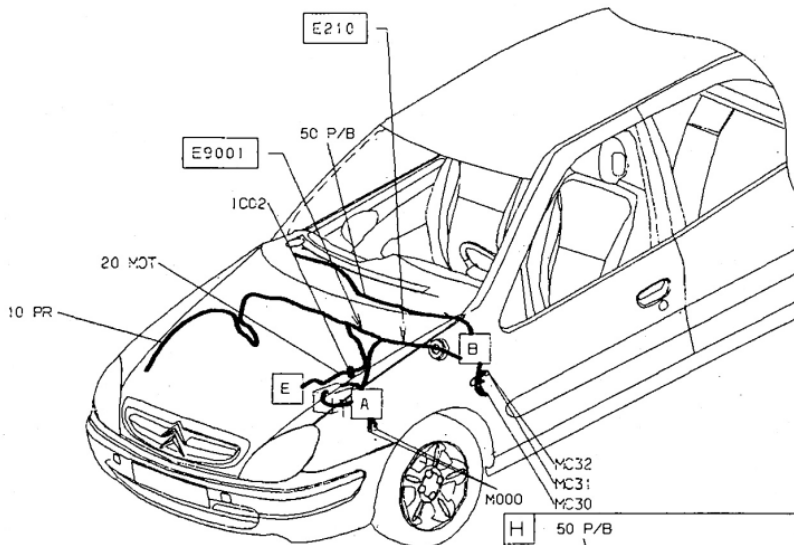

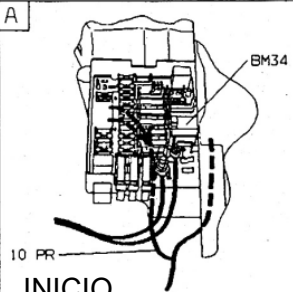
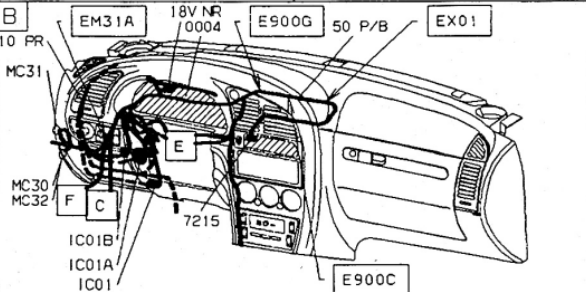
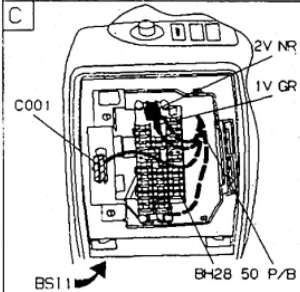
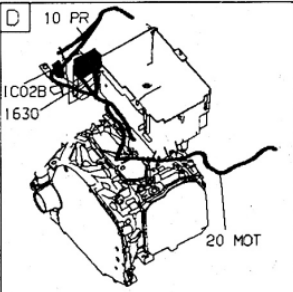
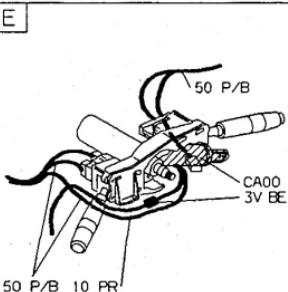
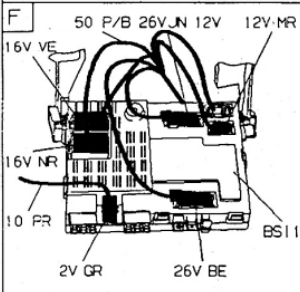
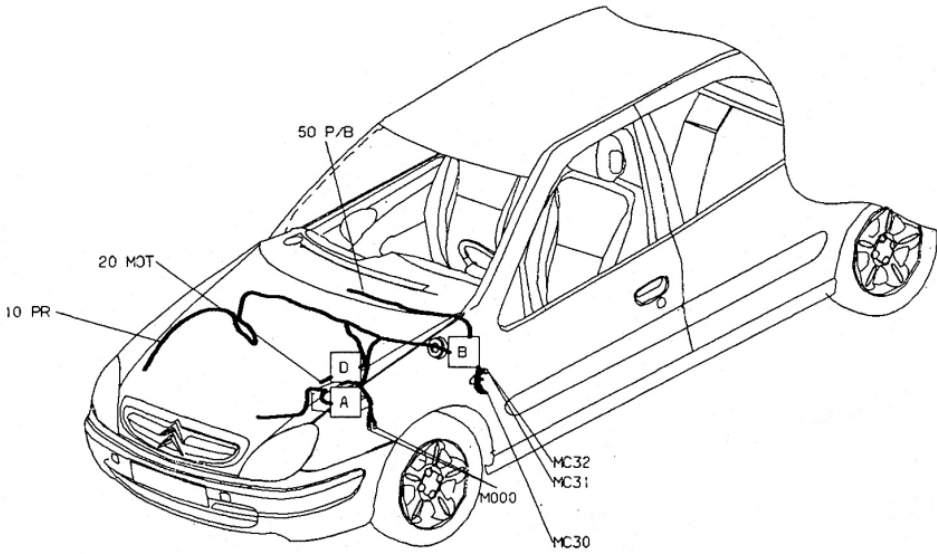

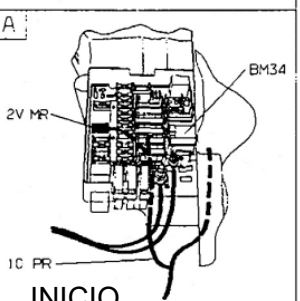
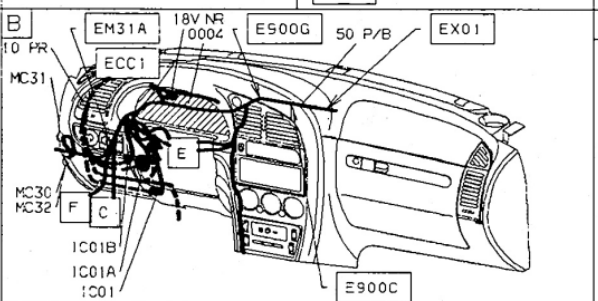
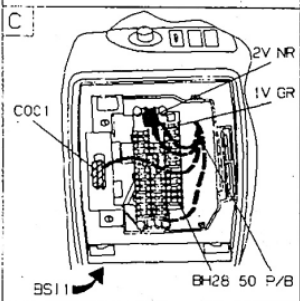
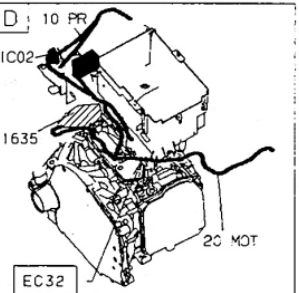
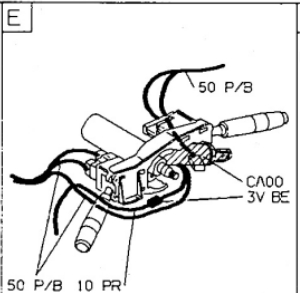
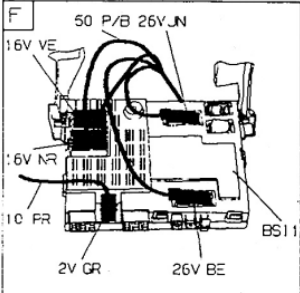
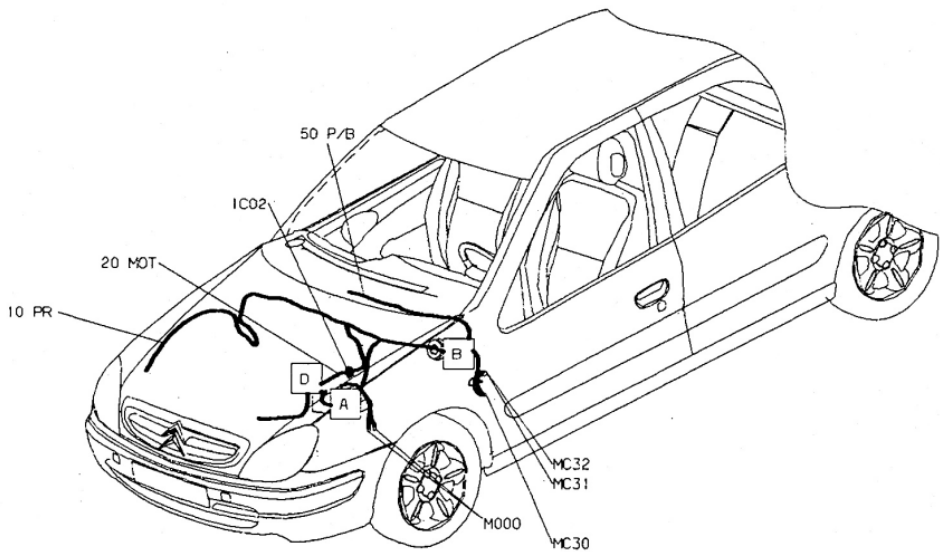

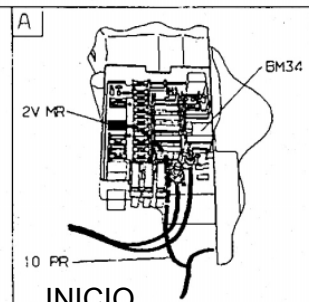
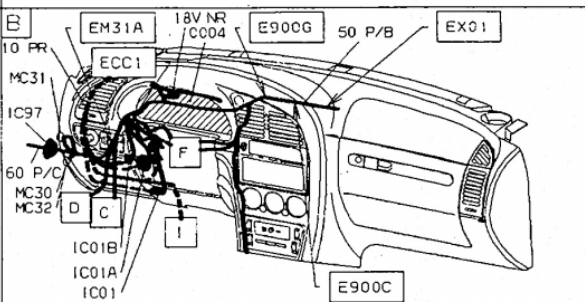
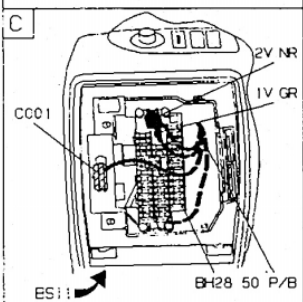
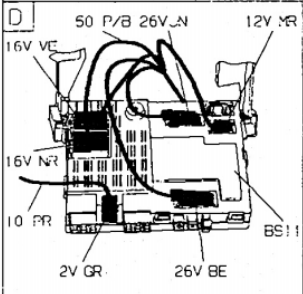
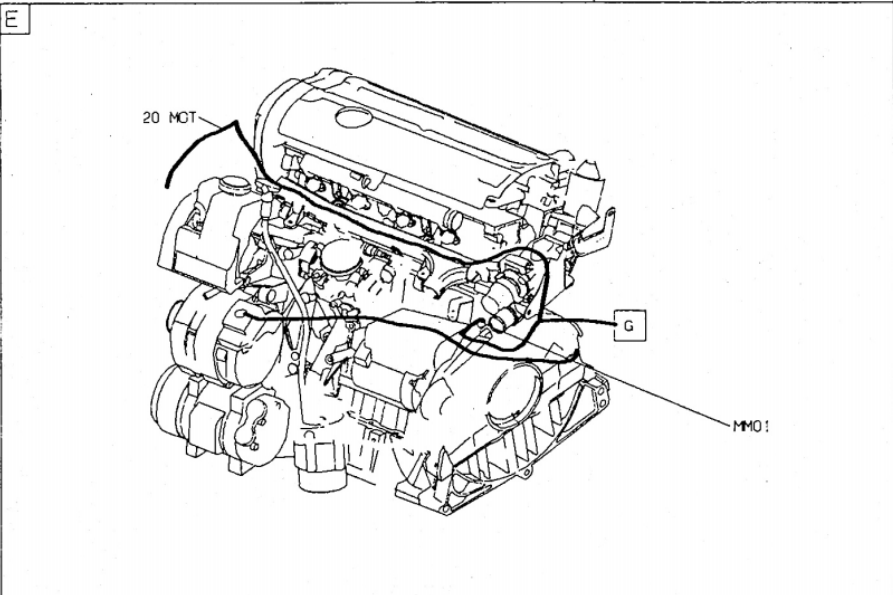
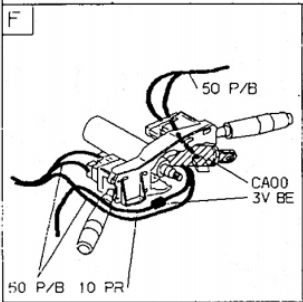
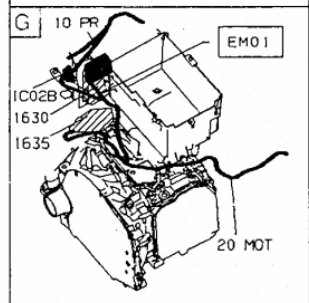
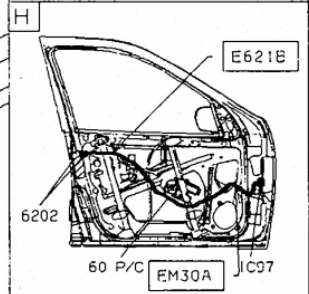
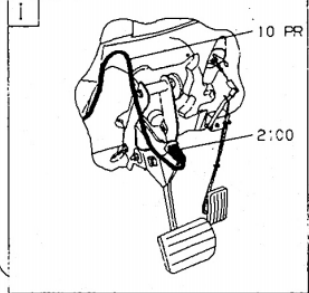
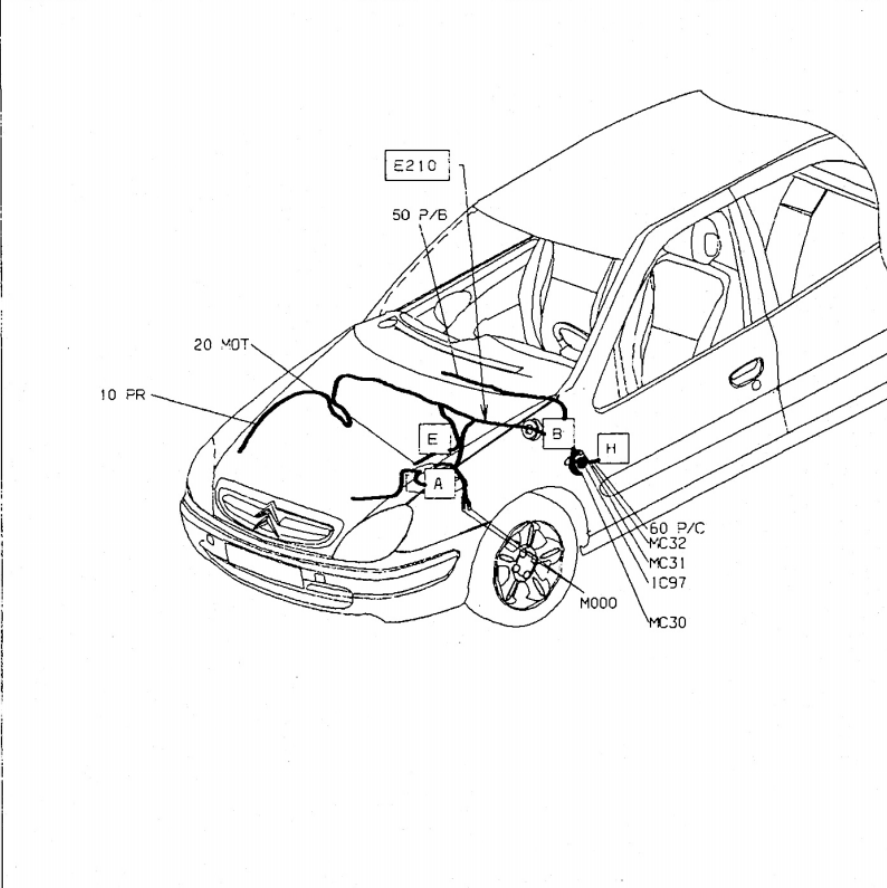

INICIO

Axuda a conducción

ABS

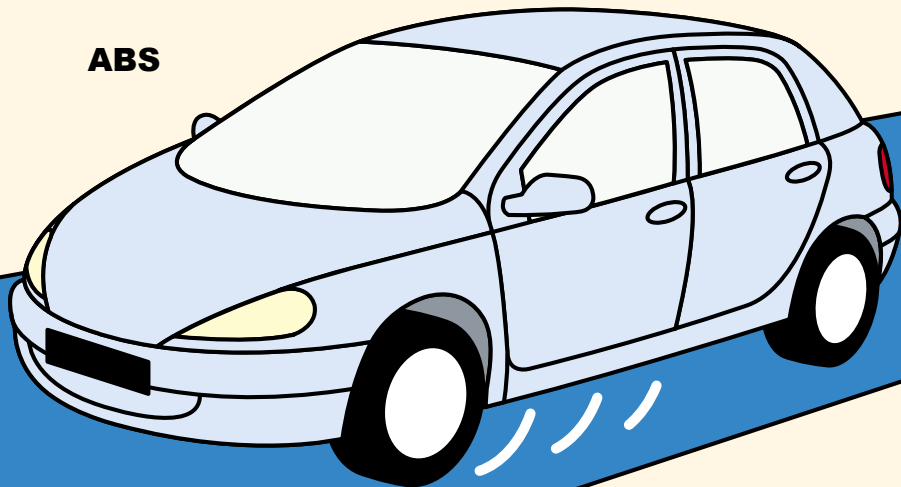

INICIO

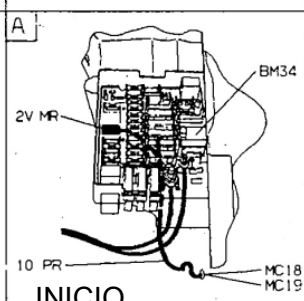
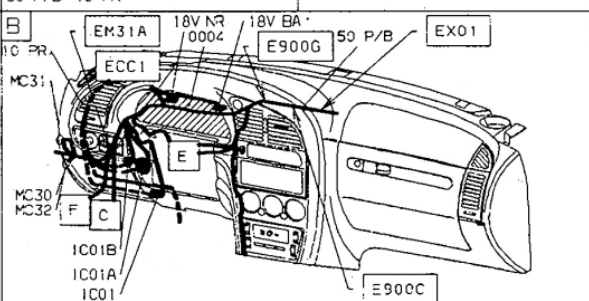
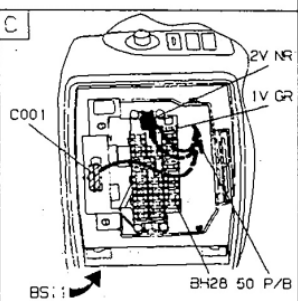
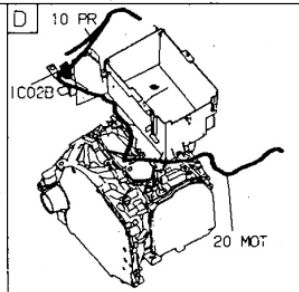
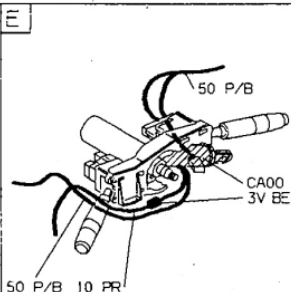
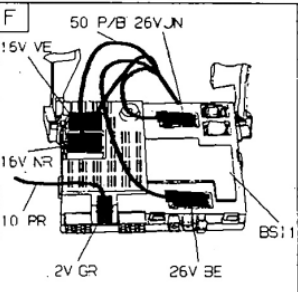
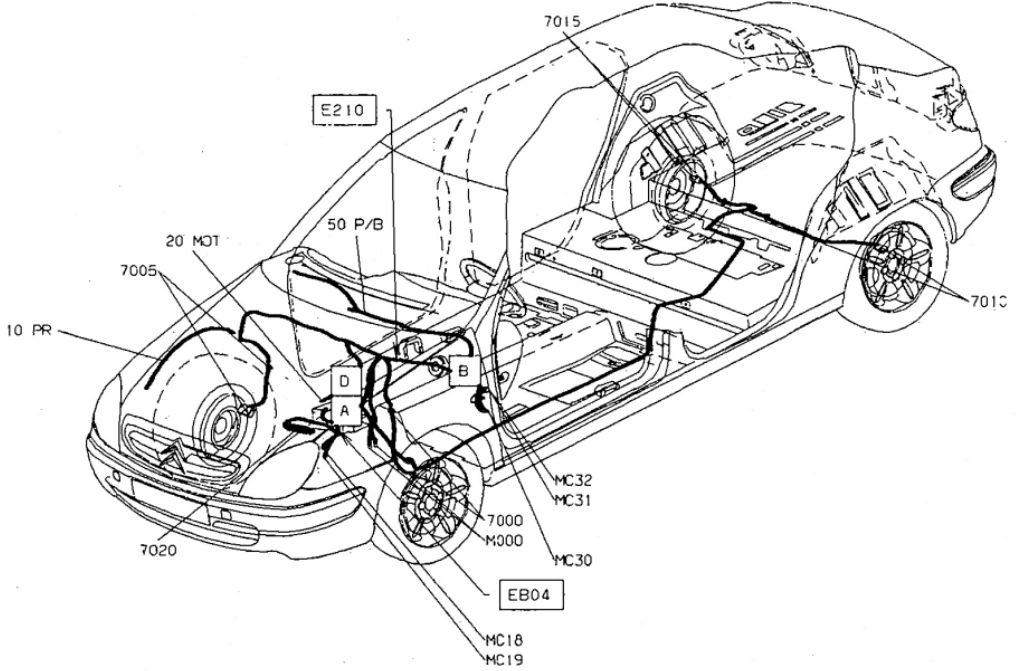

Sinalización e iluminación

Iluminación interior

Iluminación exterior

Luces stop

Bocina

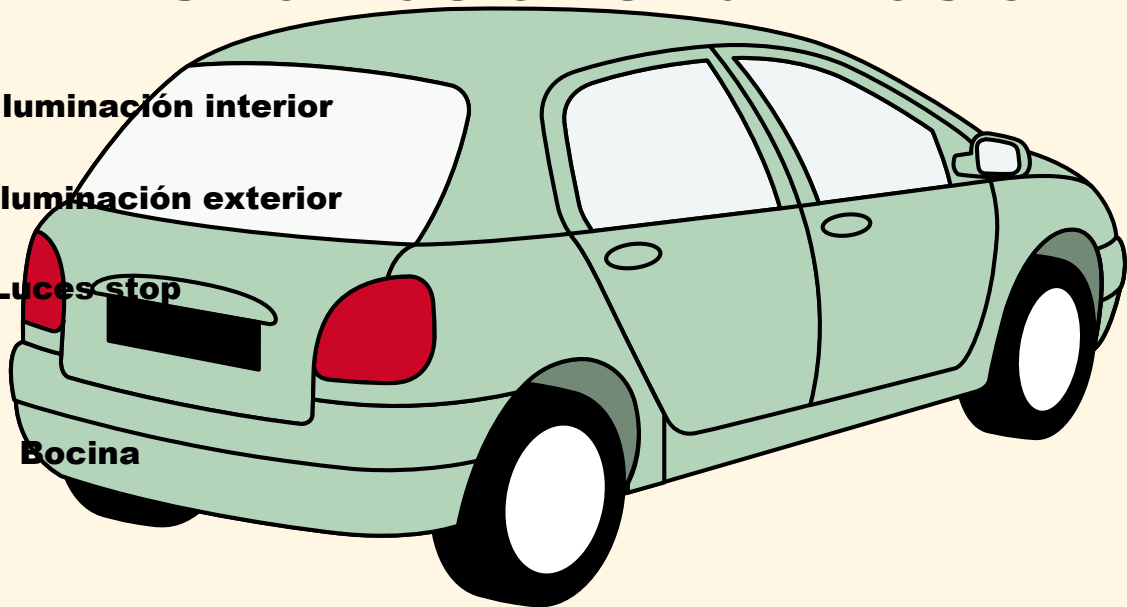

INICIO

Illuminación interior



INICIO

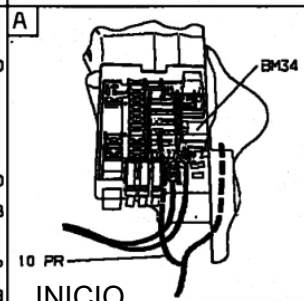
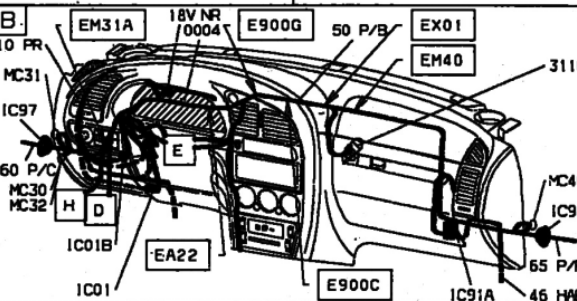
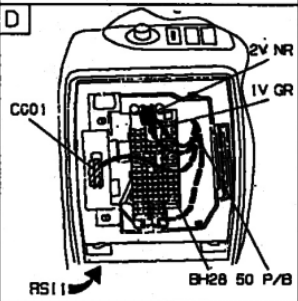
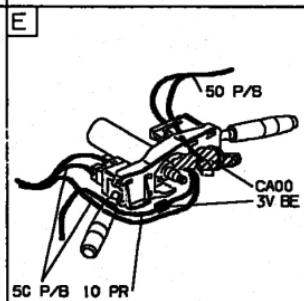
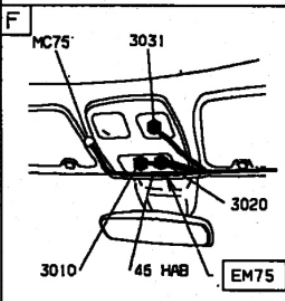
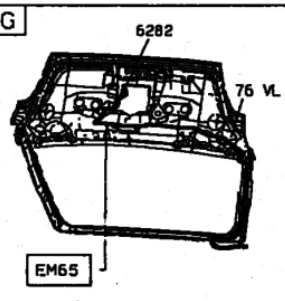
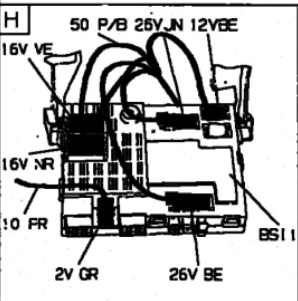
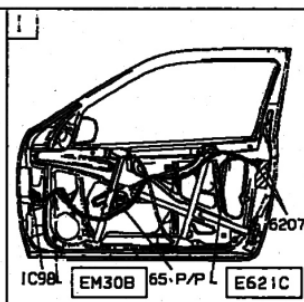
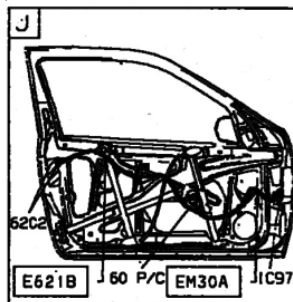
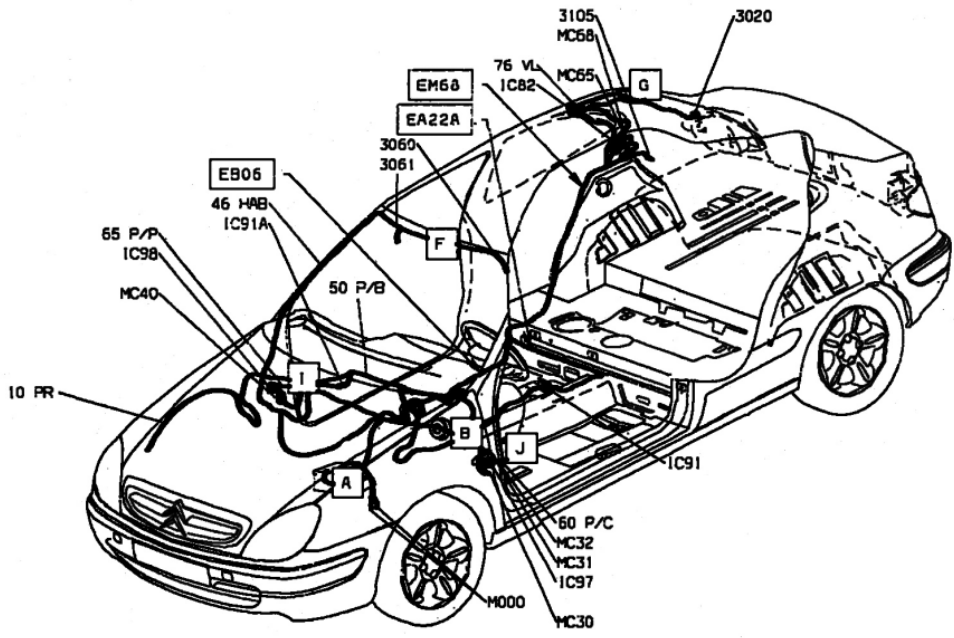

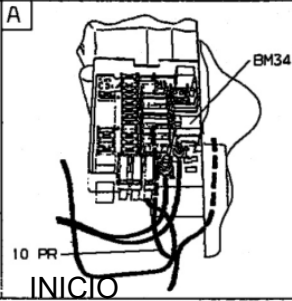
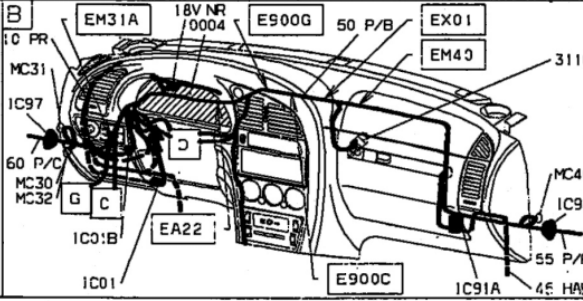
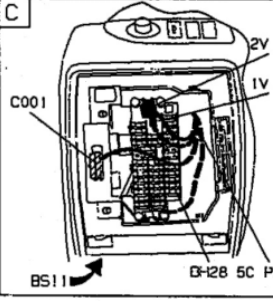
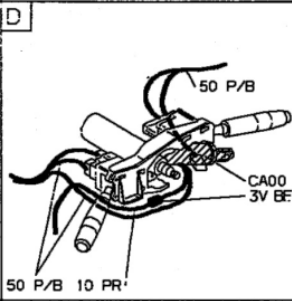
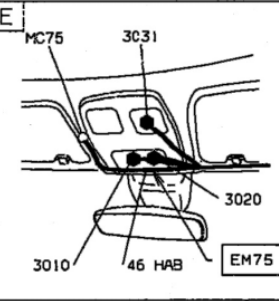
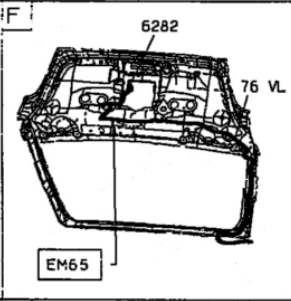
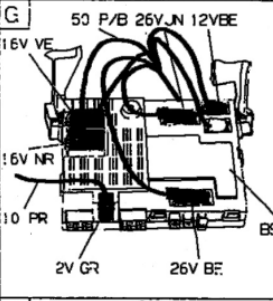
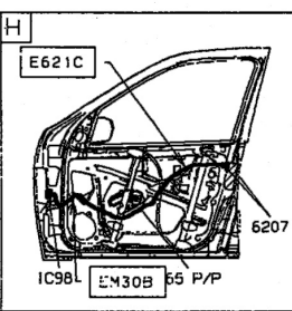
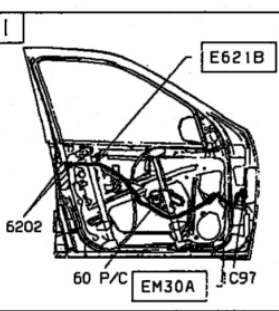
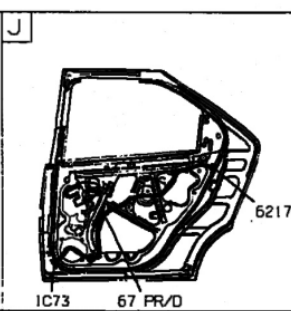
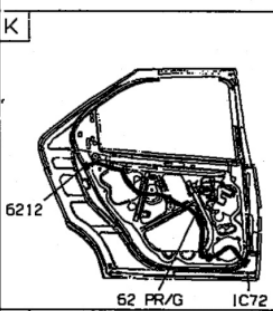
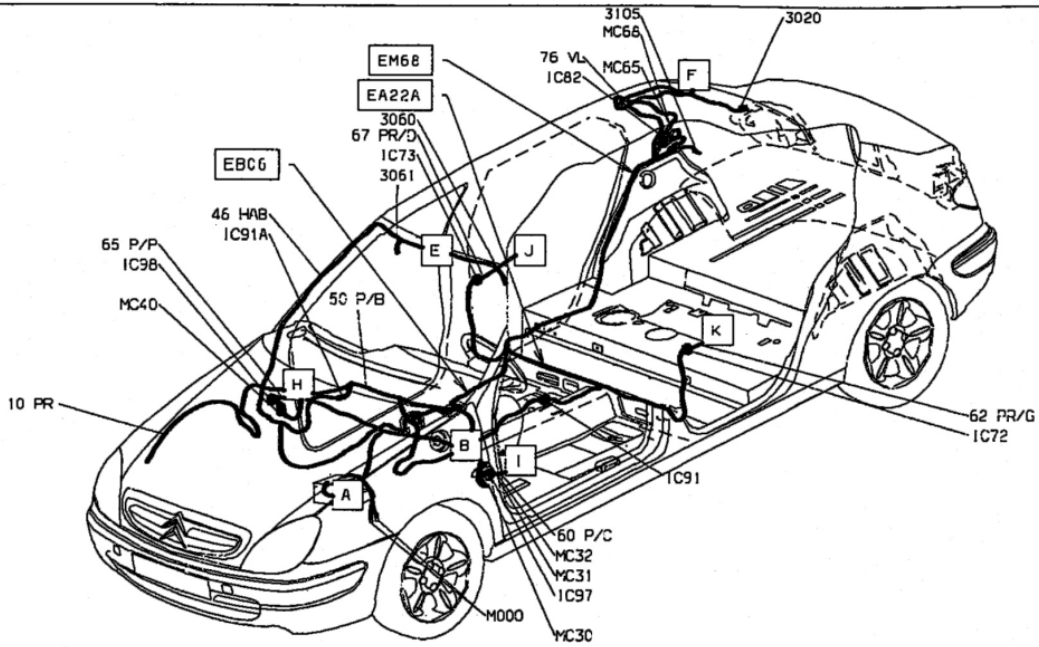

INICIO

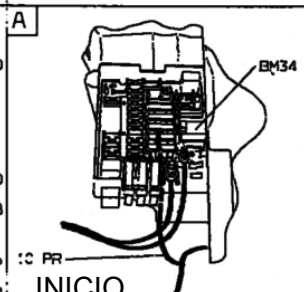
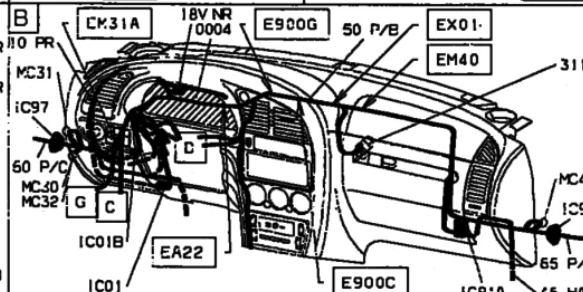
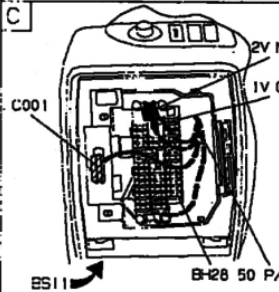
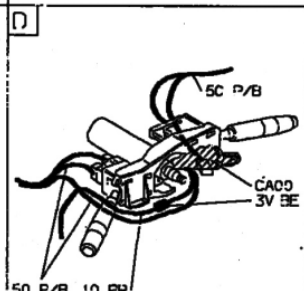
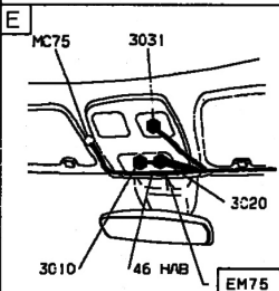
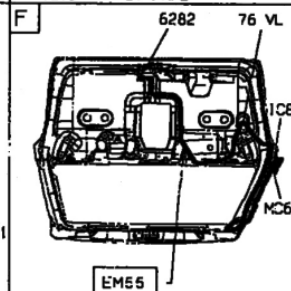
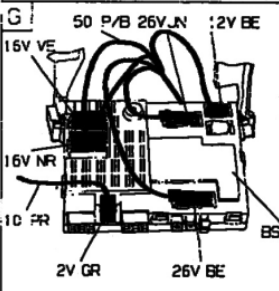
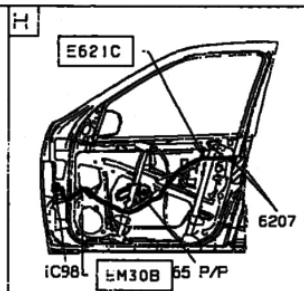
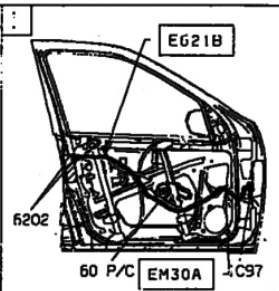
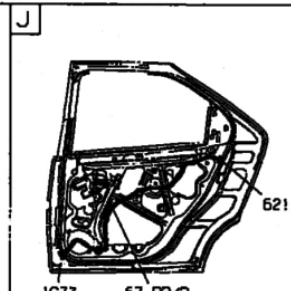
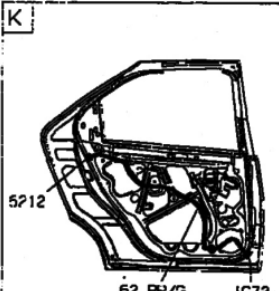
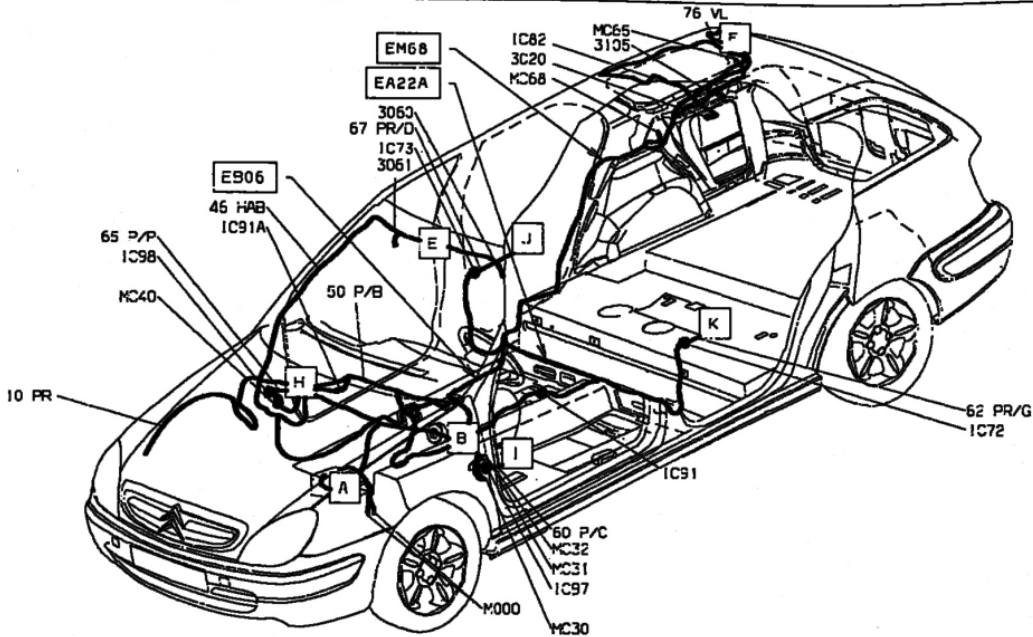

Iluminación exterior

3 portas

5 portas

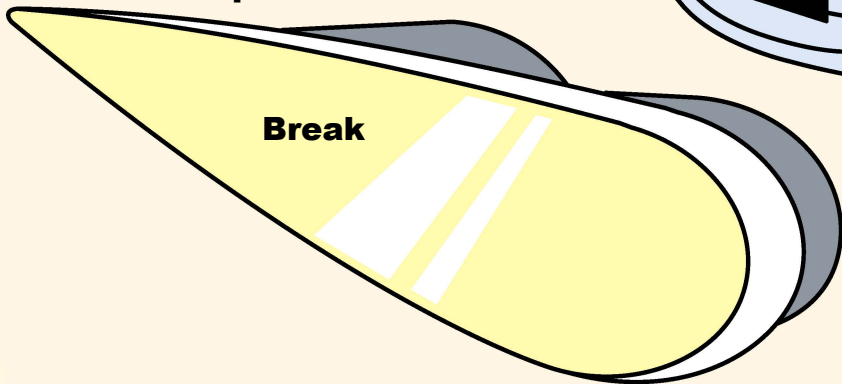

INICIO

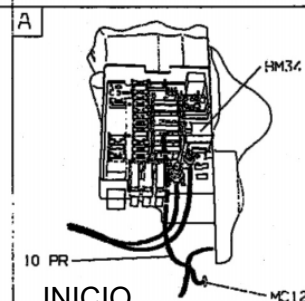
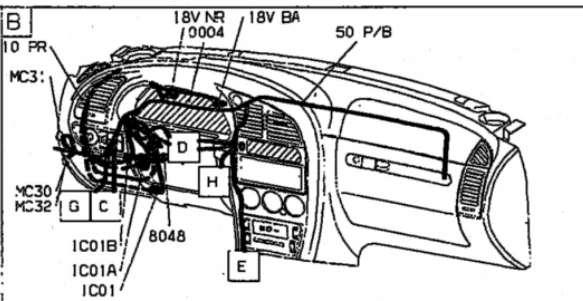
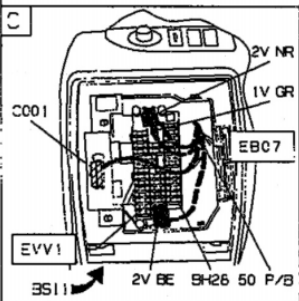
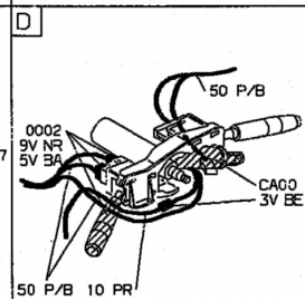
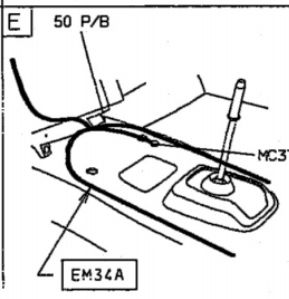
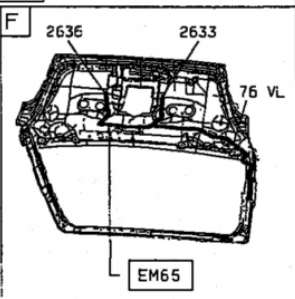
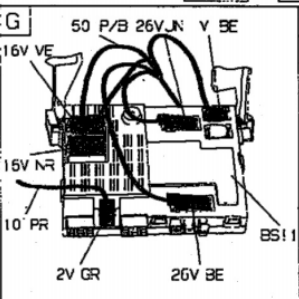
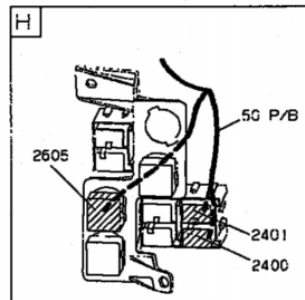
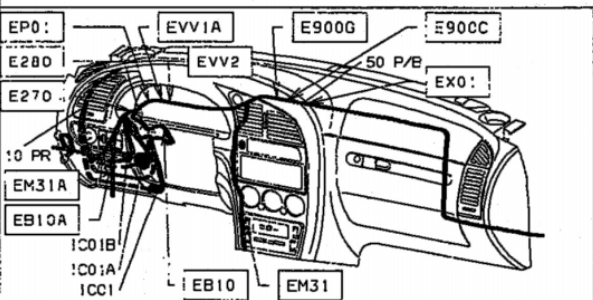
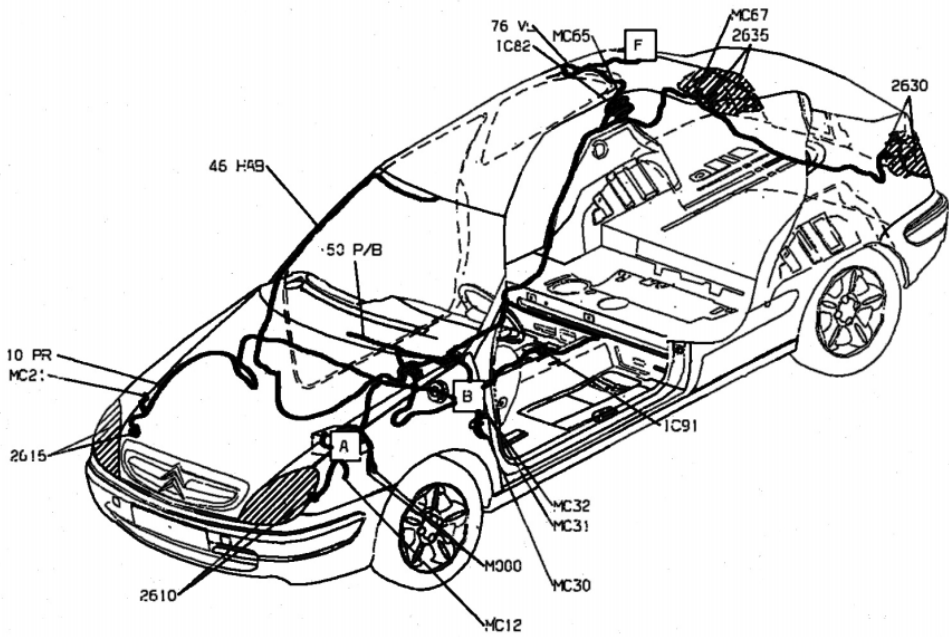

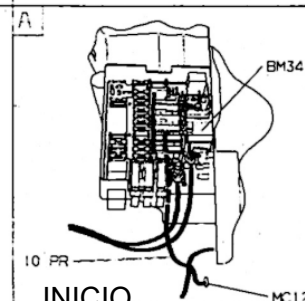
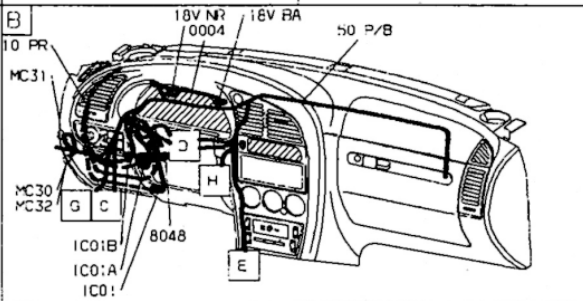
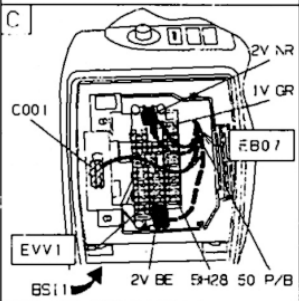
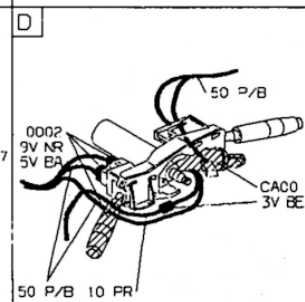
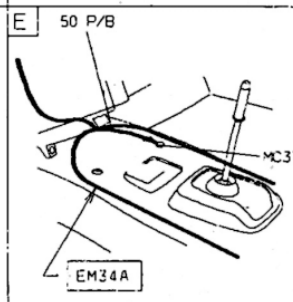
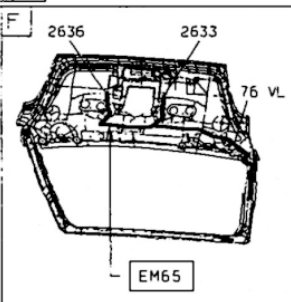
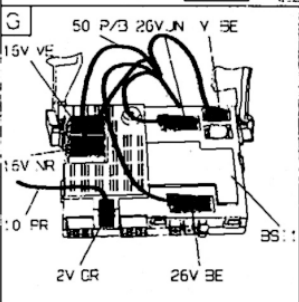
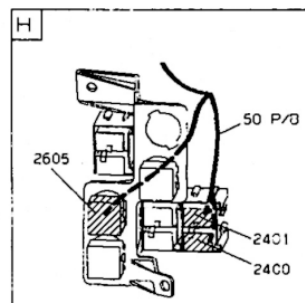
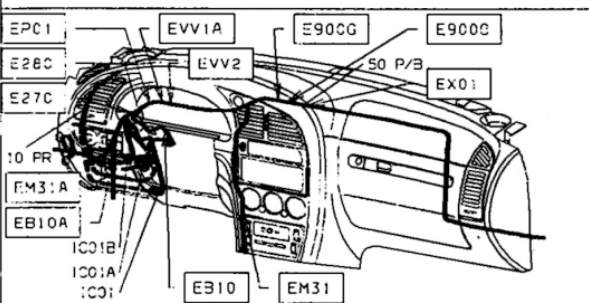
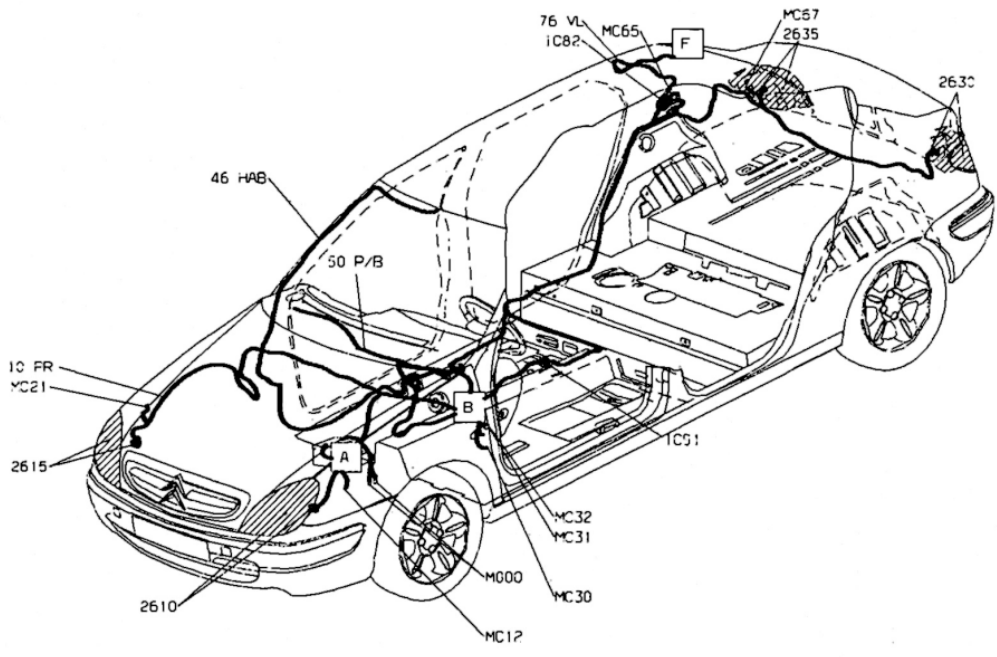

INICIO

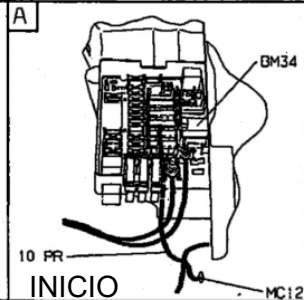
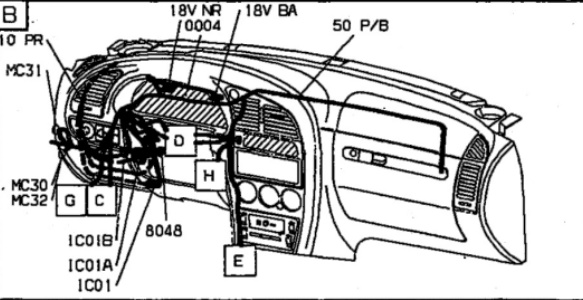
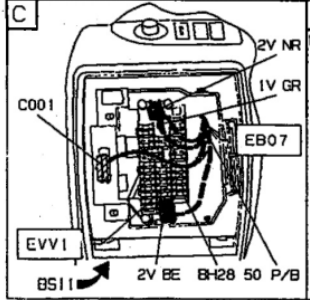
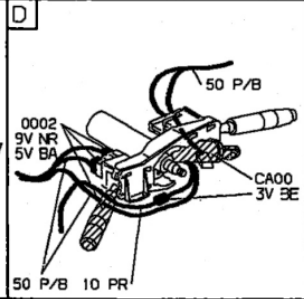
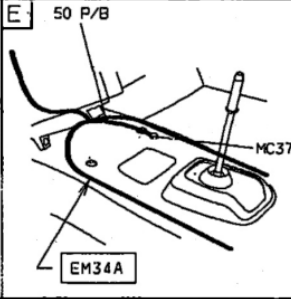
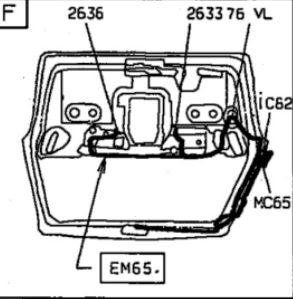
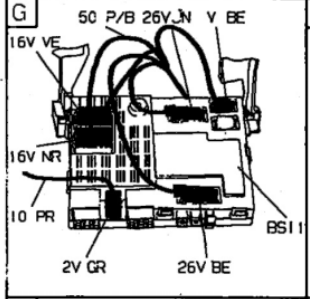
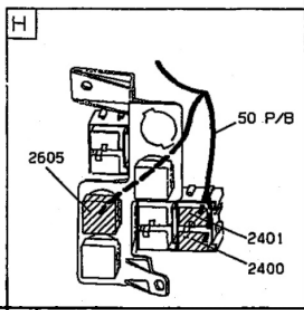
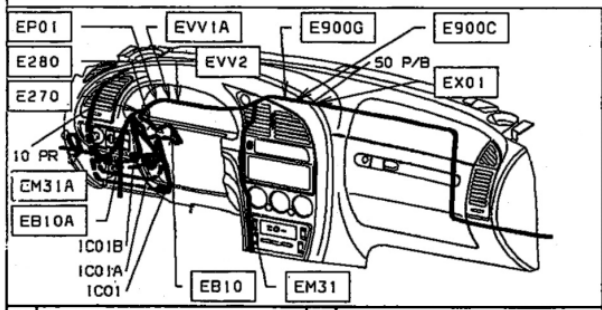
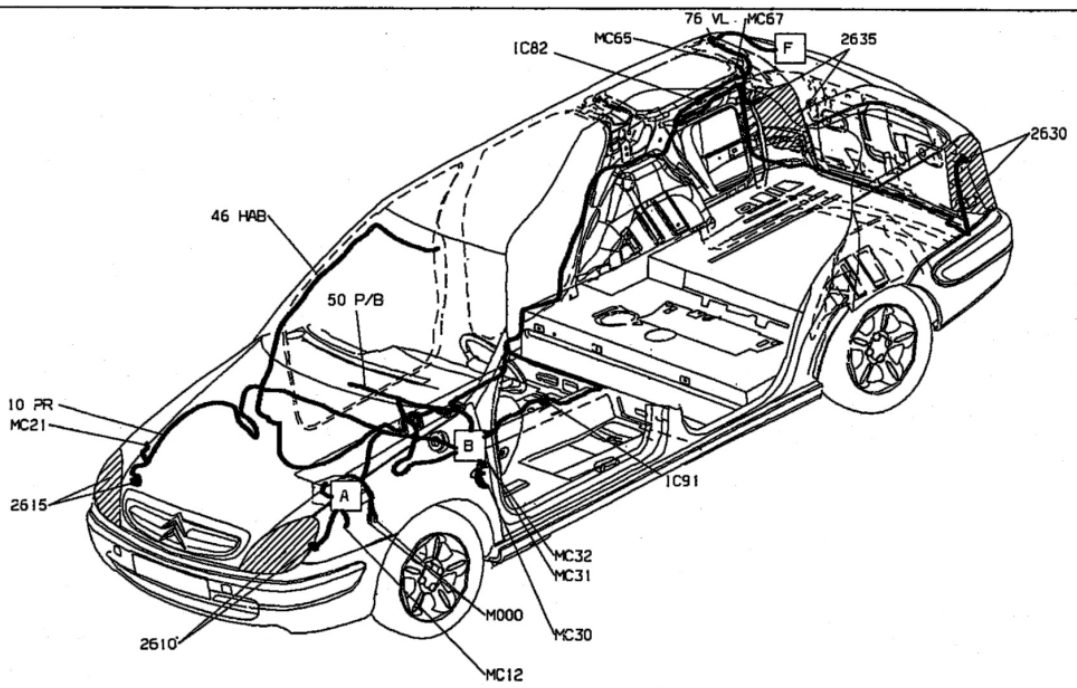

Luces stop

3 e 5 portas

Break

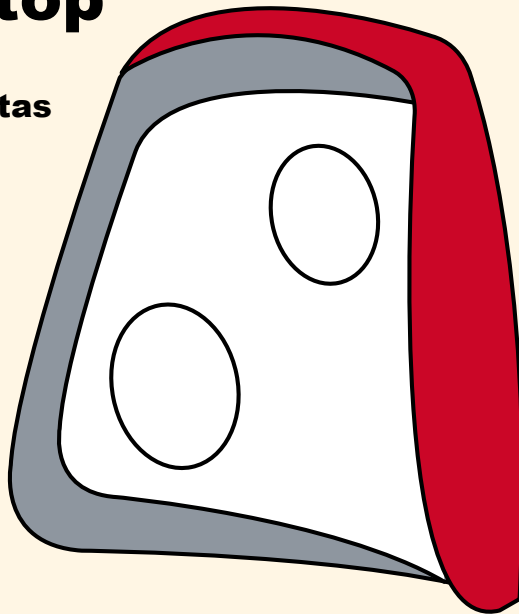
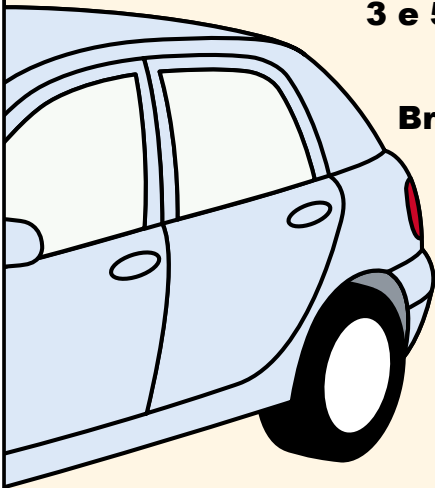

INICIO

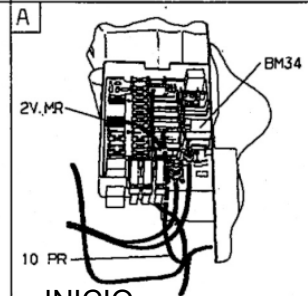
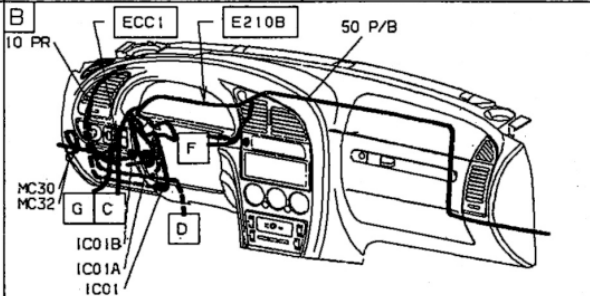
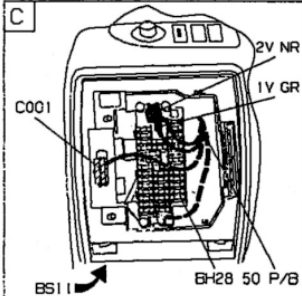
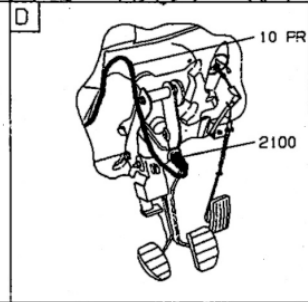
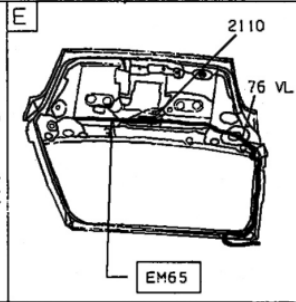
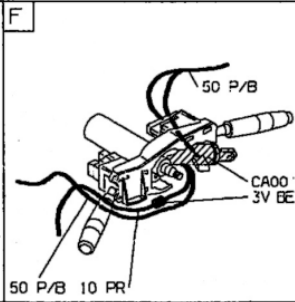
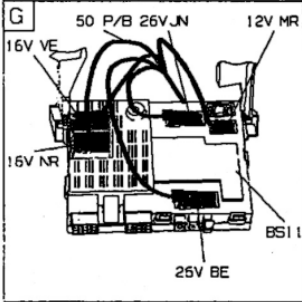
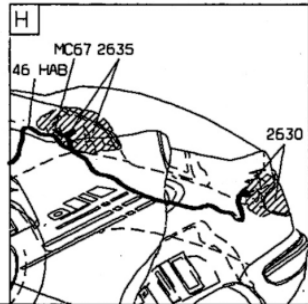
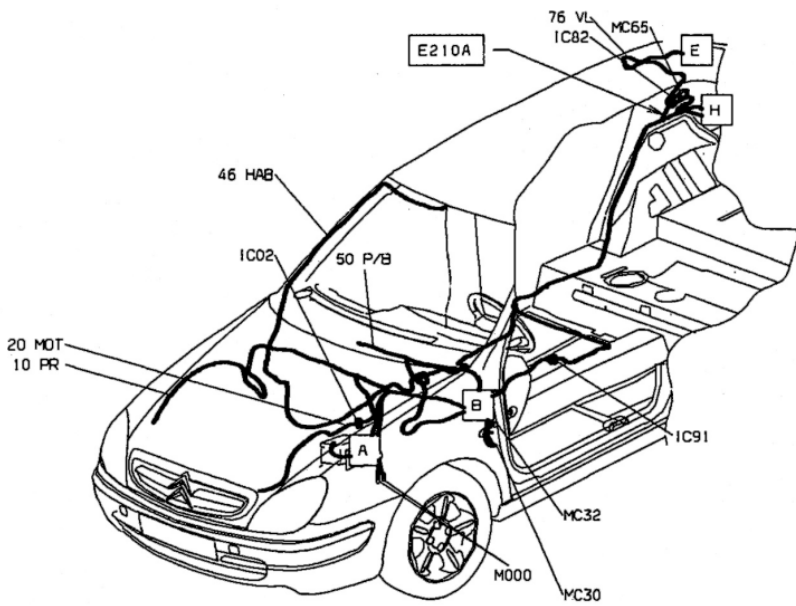

INICIO

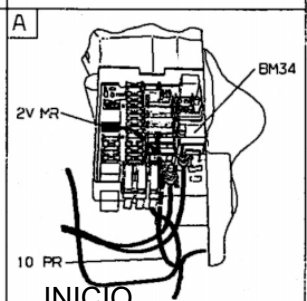
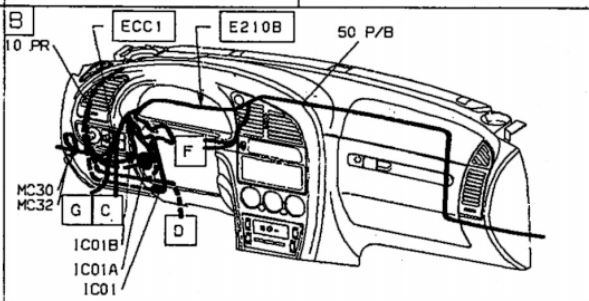
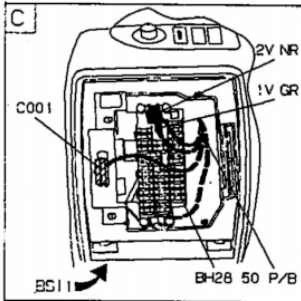
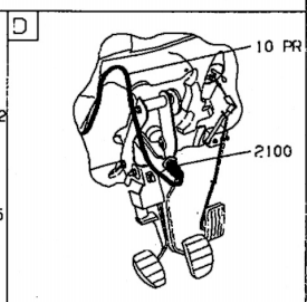
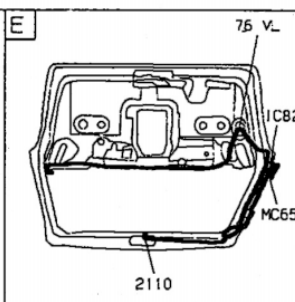
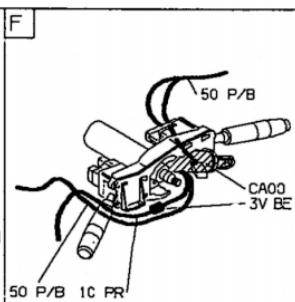
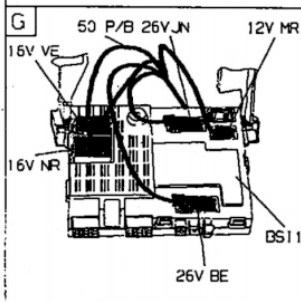
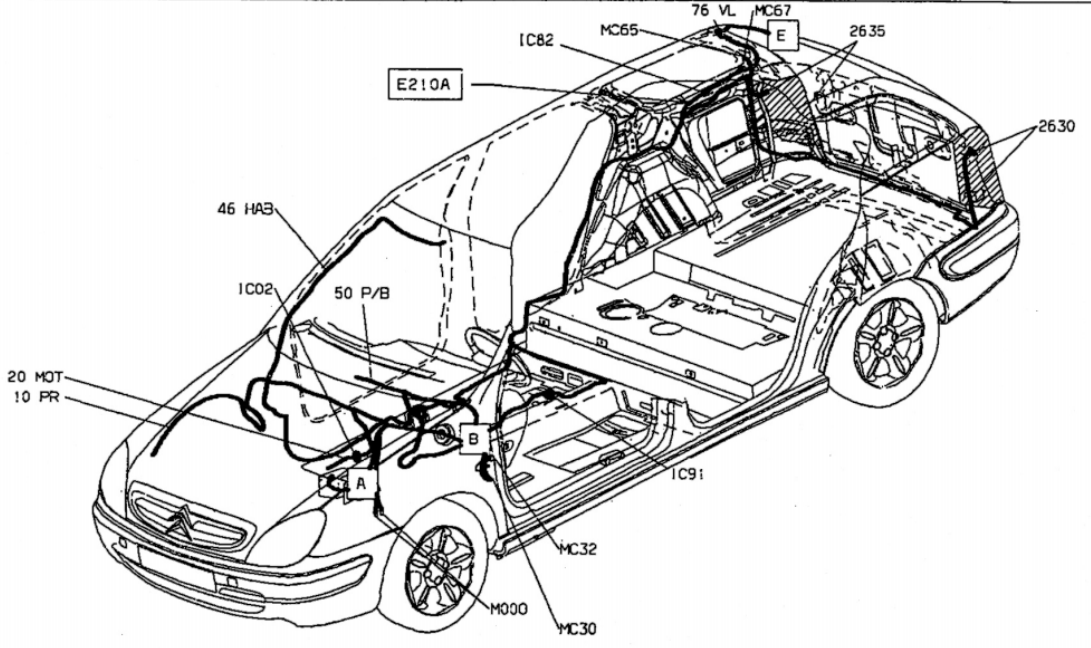

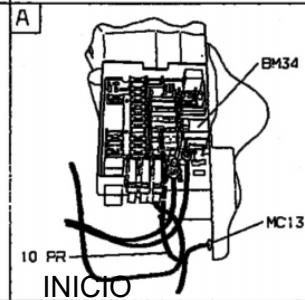
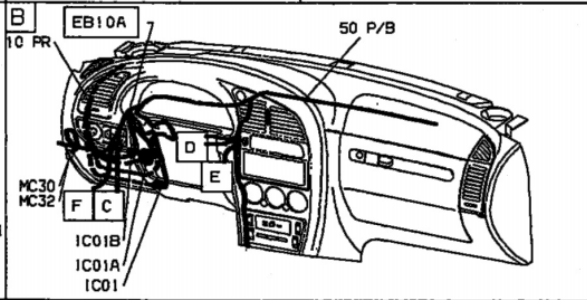
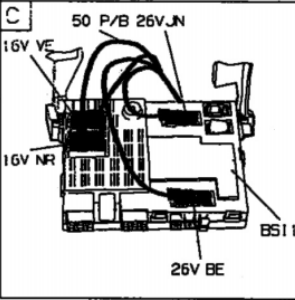
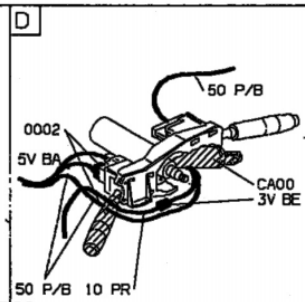
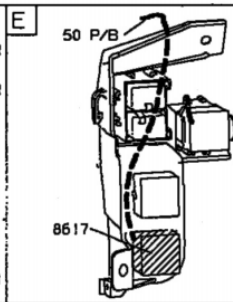
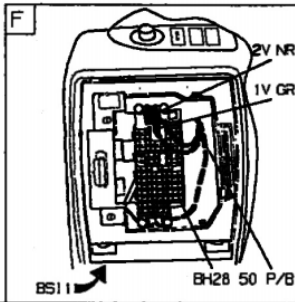
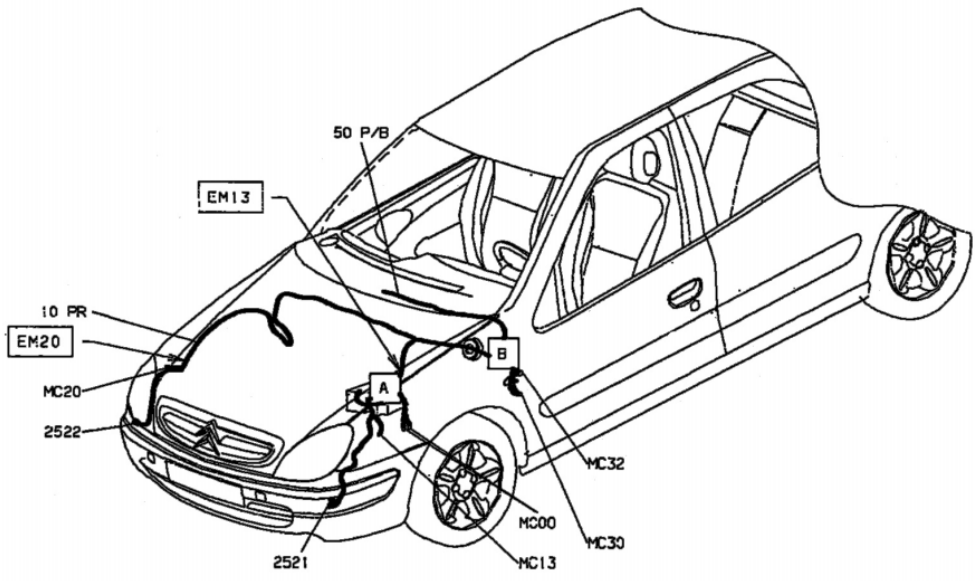



Información conductor

Cadro instrumentos

Axuda estacionamento

Reloxío analóxico

Ordenador de bordo

INICIO

Cadro de instrumentos

Aforador combustible

Testigo temperatura motor

Testigo cinturón de seguridade

Testigo desgaste pastillas de freno

Testigo líquido de freno e freno de man

Información portas abertas

Testigo nivel presión aceite

Testigo presenza
agua en gasoil

Zumbador esquecemento
chave

Zumbador
esquecemento luces

Zumbador
sobrevelocidade C.A.

Zumbador
sobrevelocidade

Testigo desgaste pastilla freno

INICIO

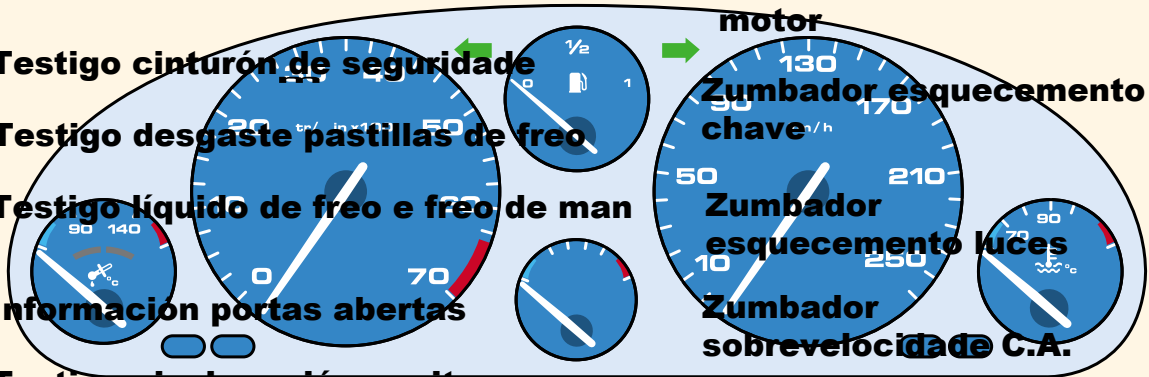

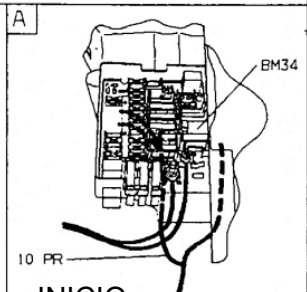
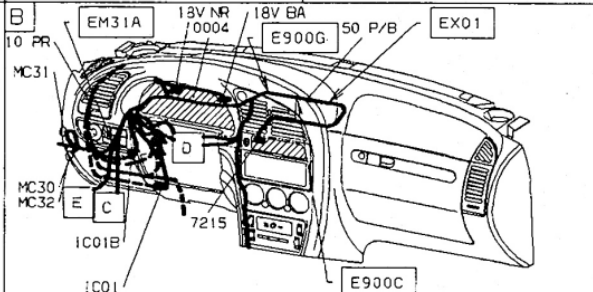
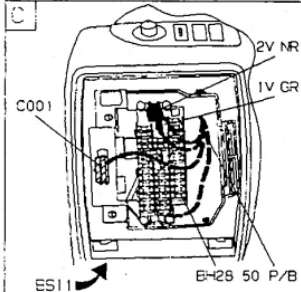
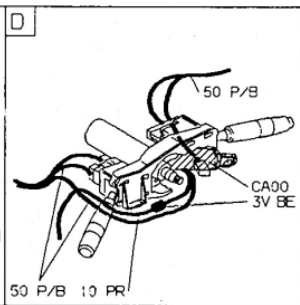
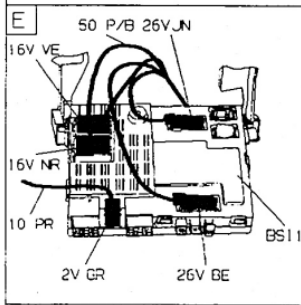
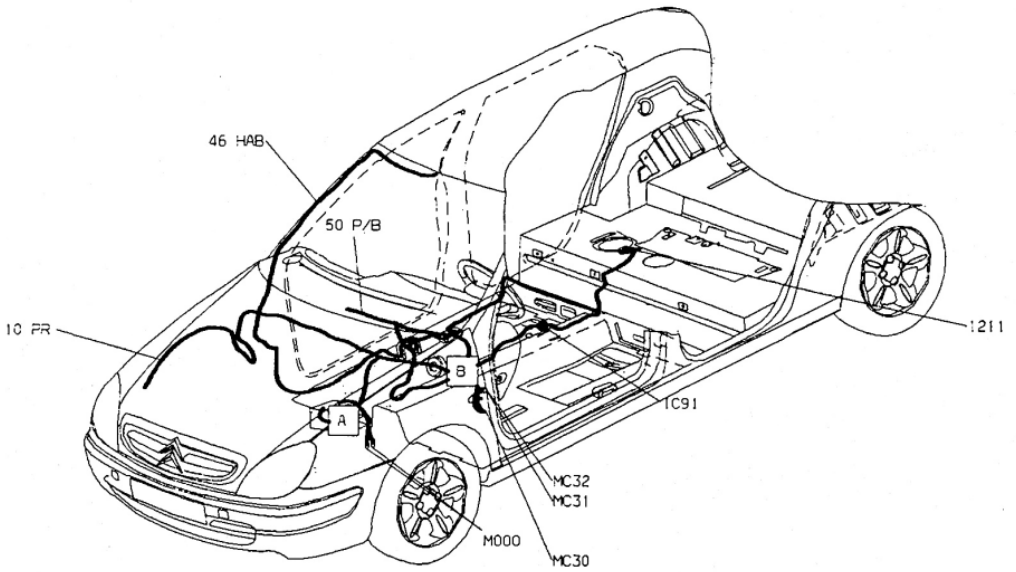

INICIO

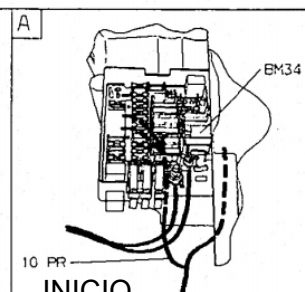
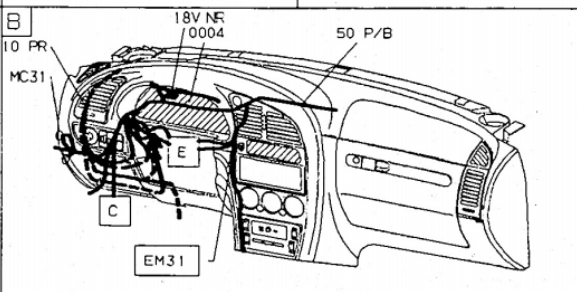
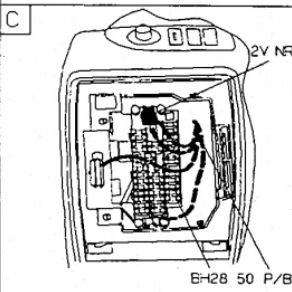
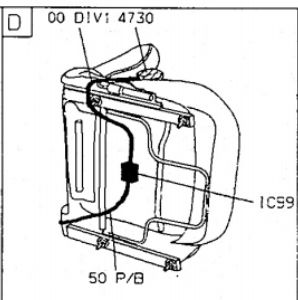
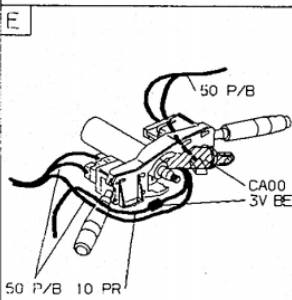
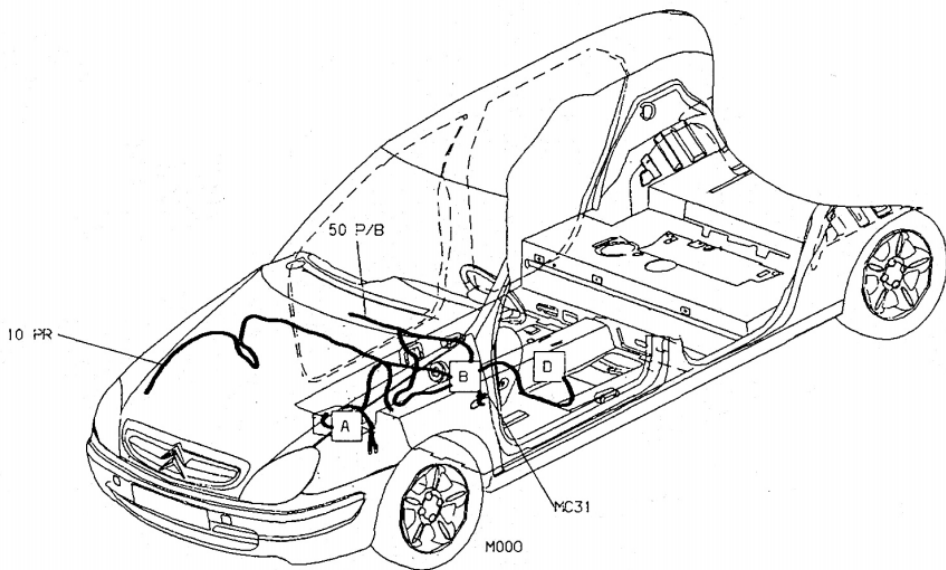

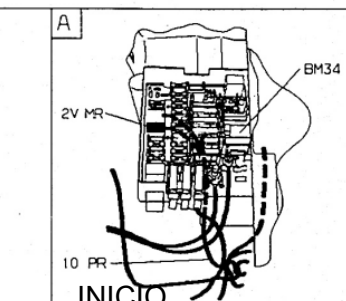
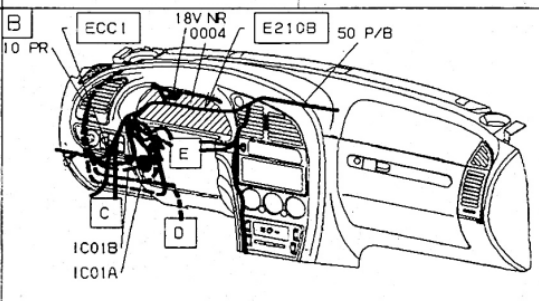
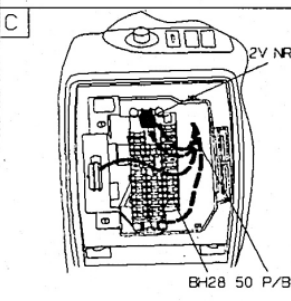
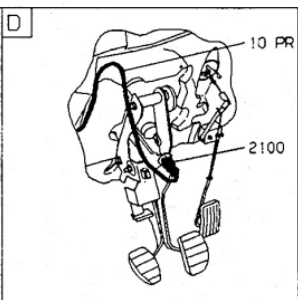
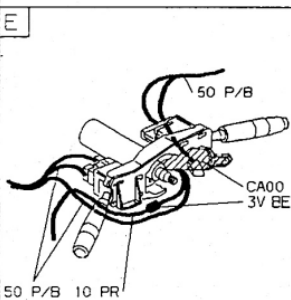
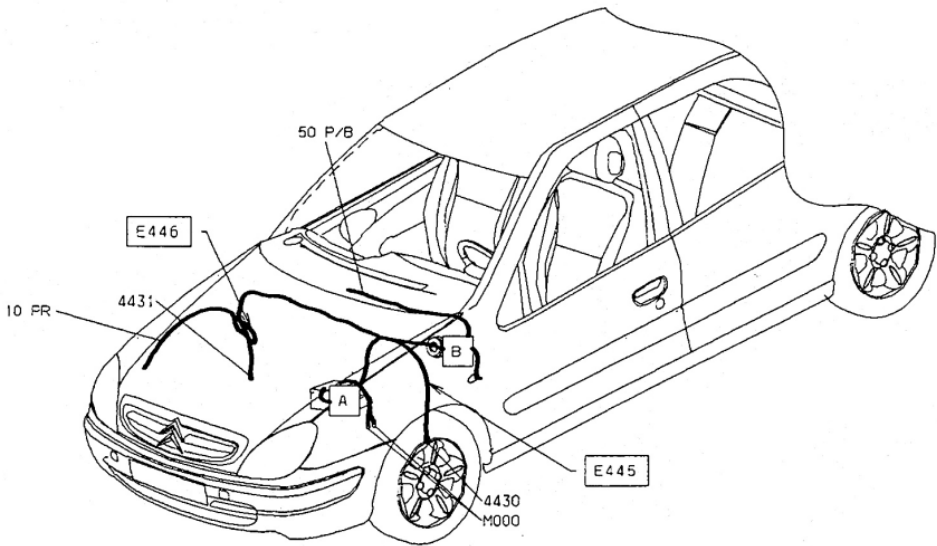

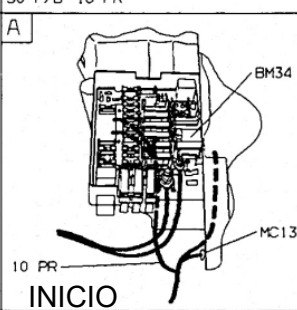
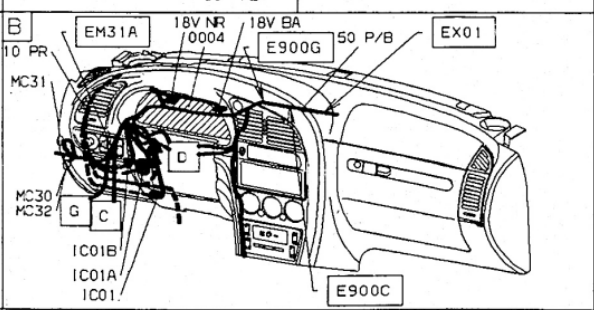
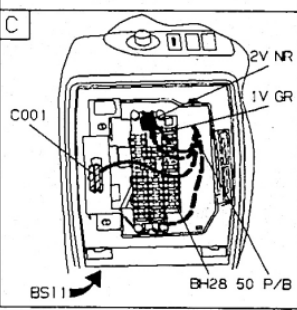
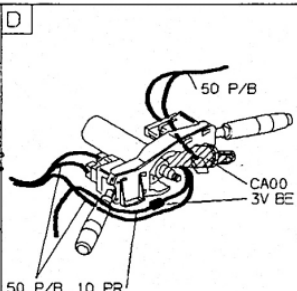
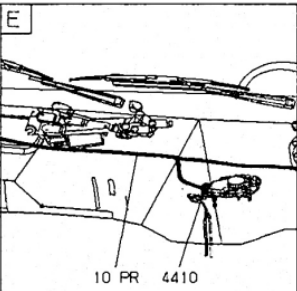
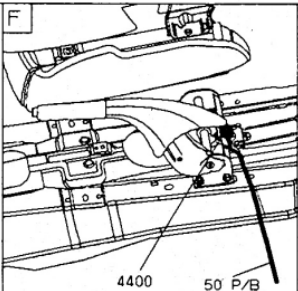
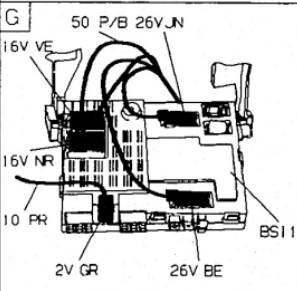
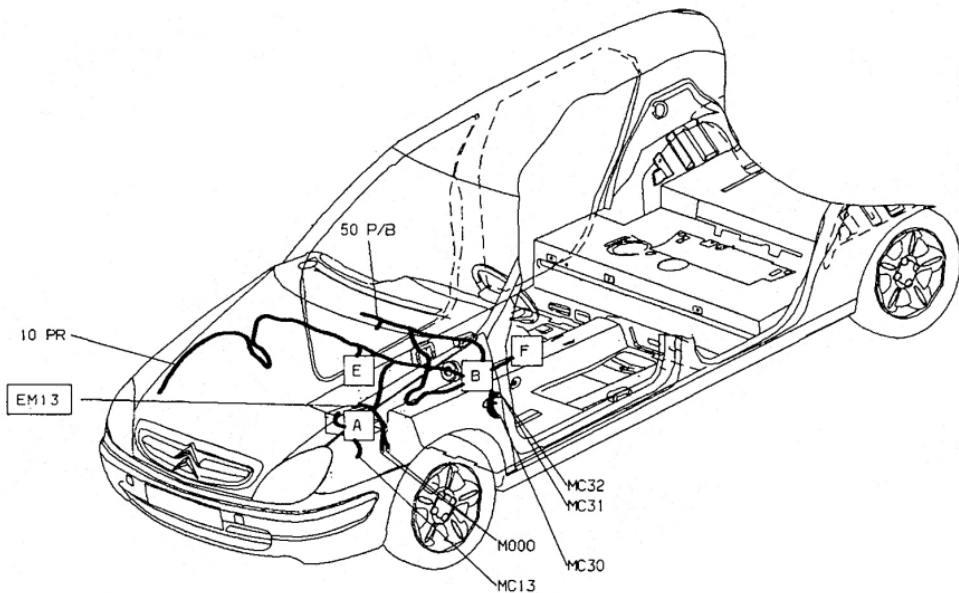

Información portas abiertas

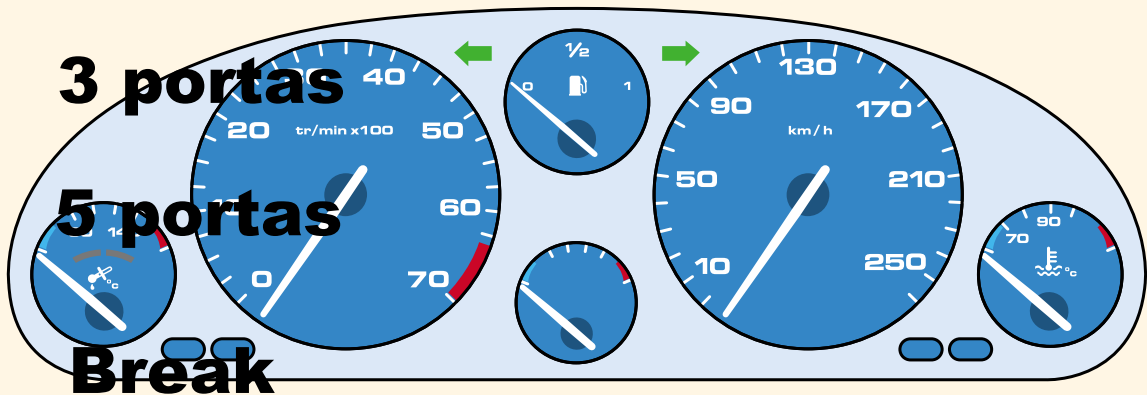

INICIO

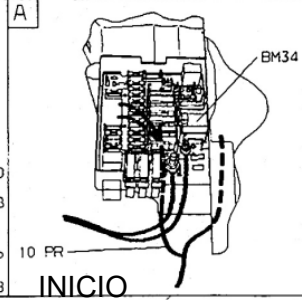
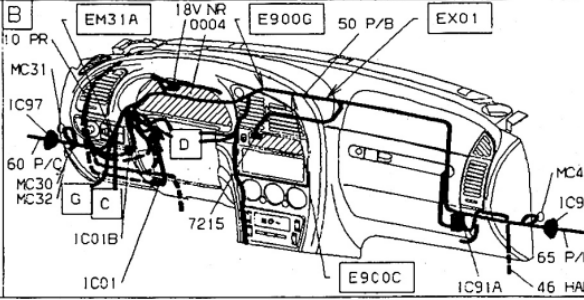
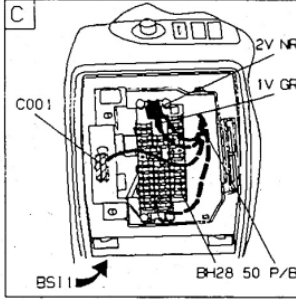
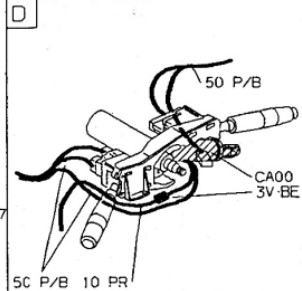
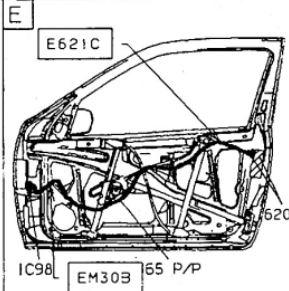
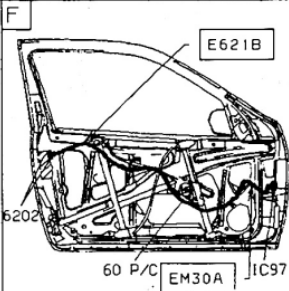
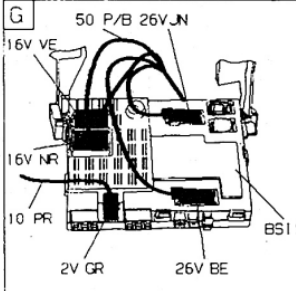
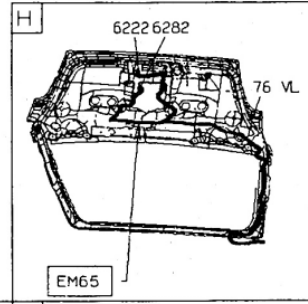
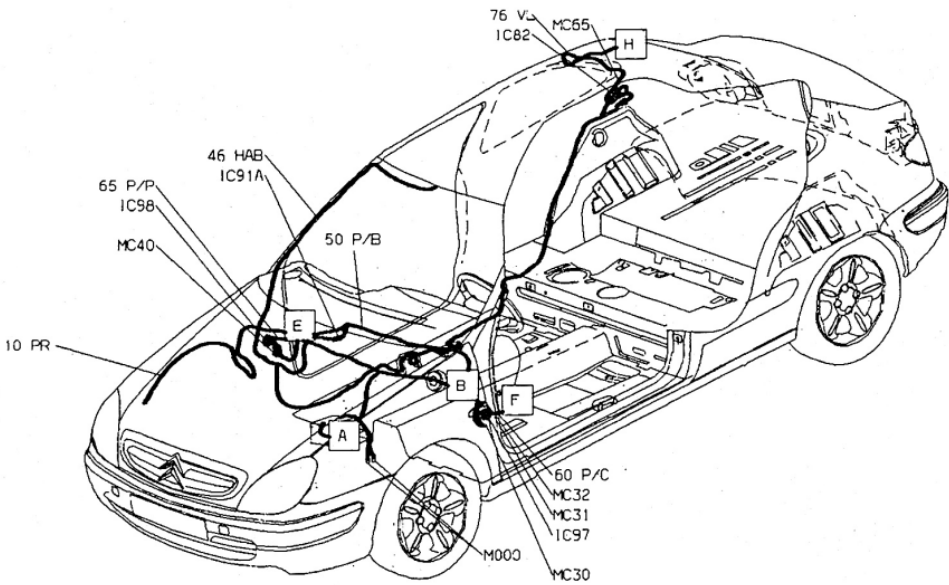

INICIO

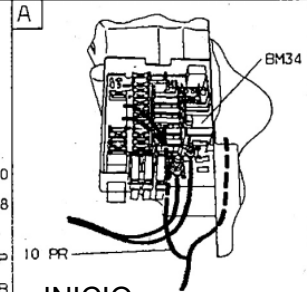
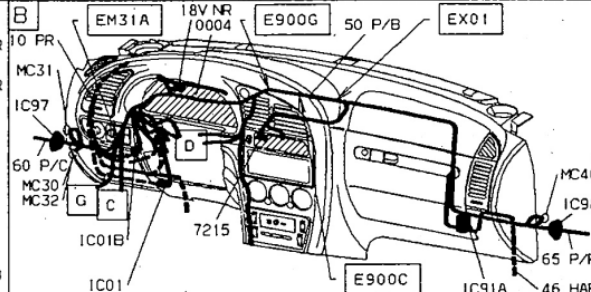
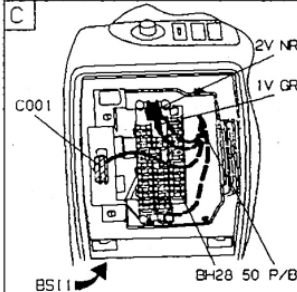
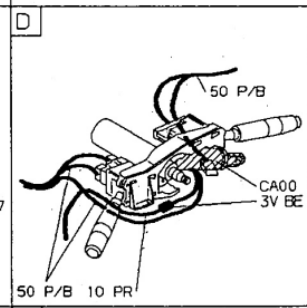
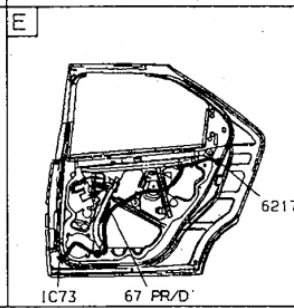
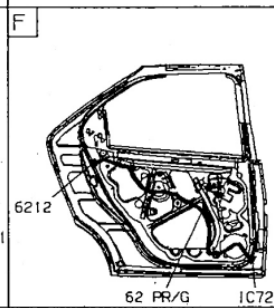
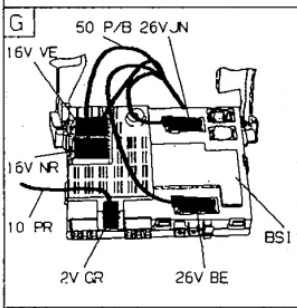
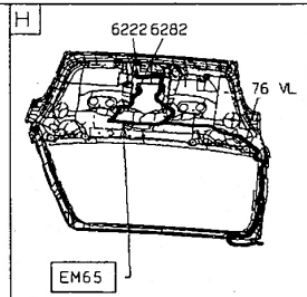
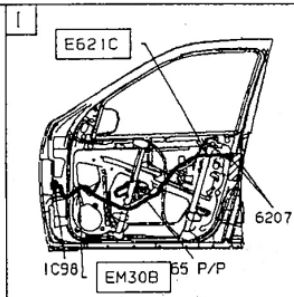
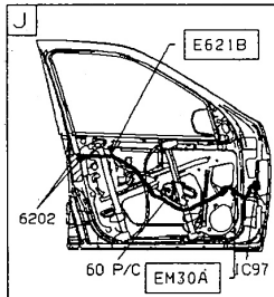
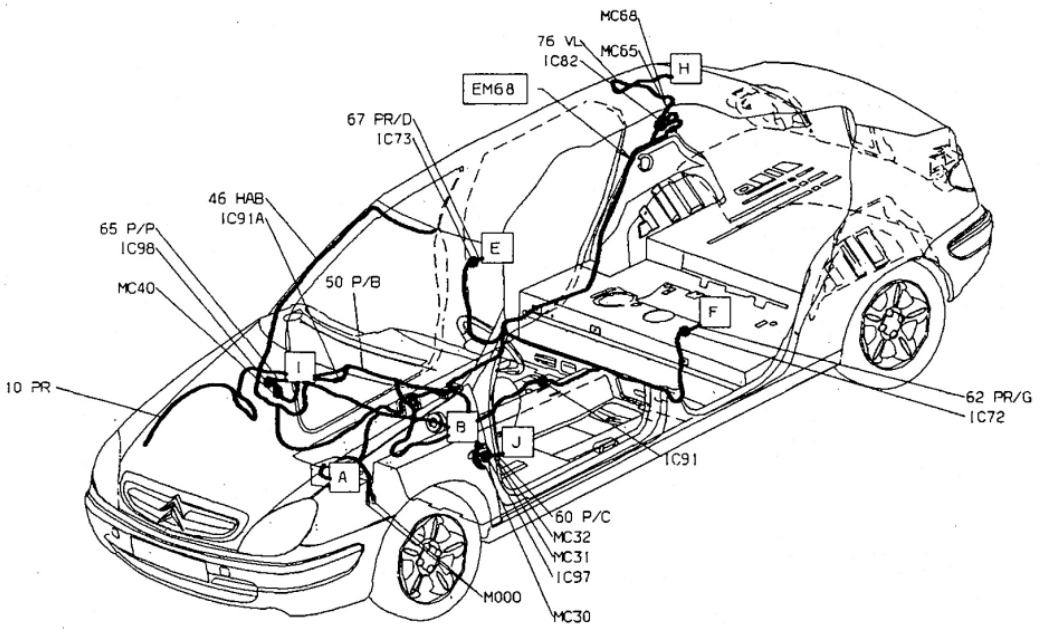

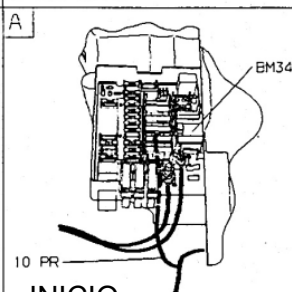
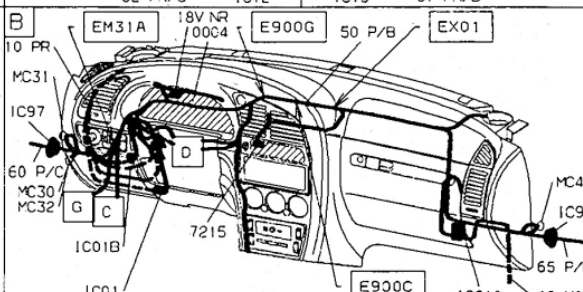
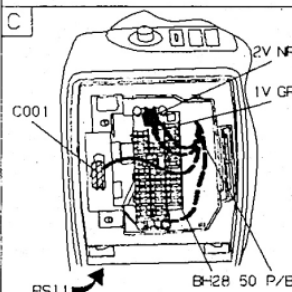
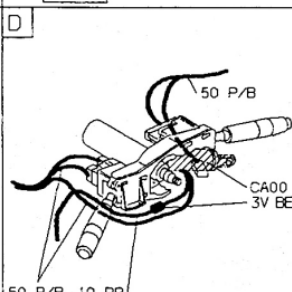
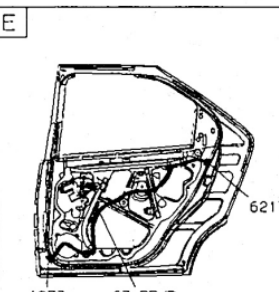
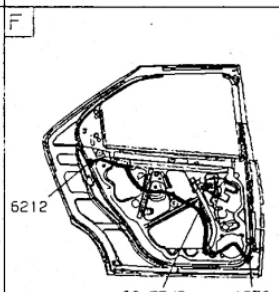
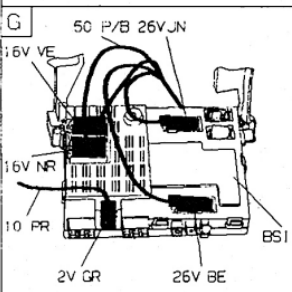
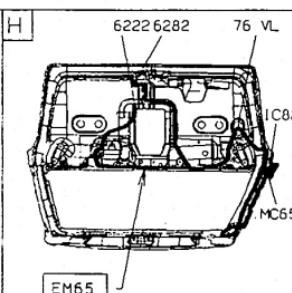
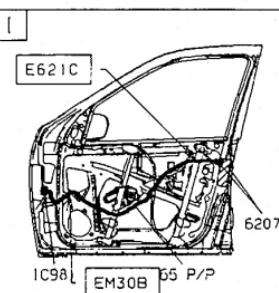
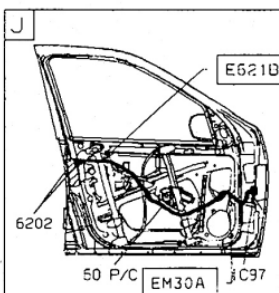
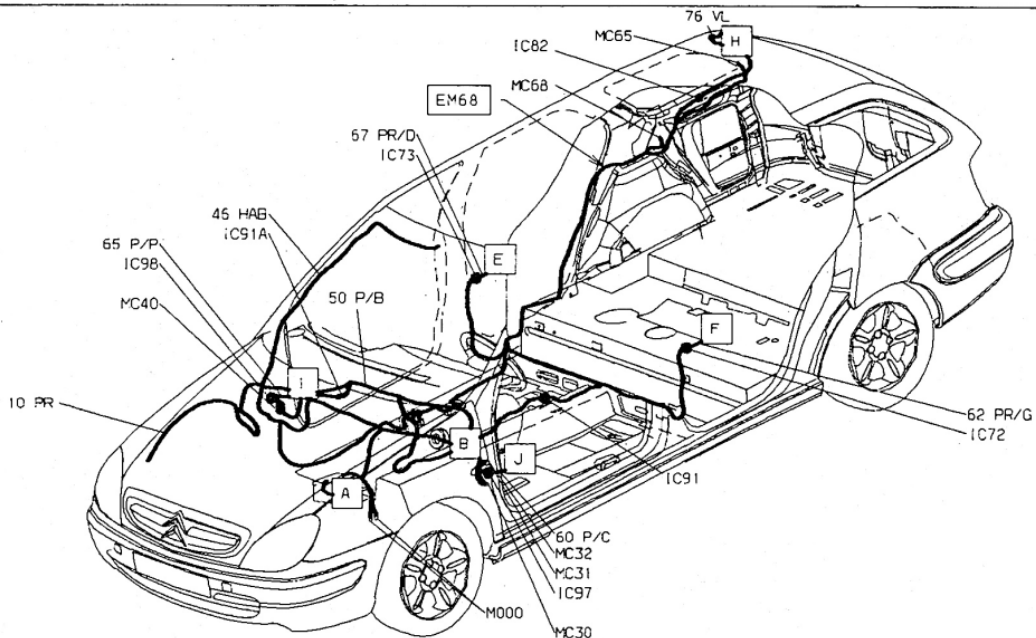

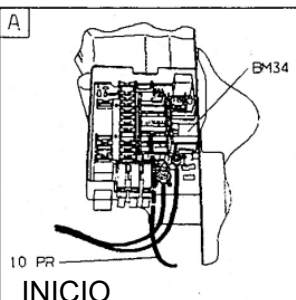
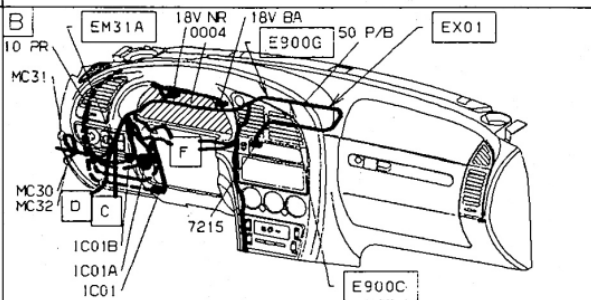
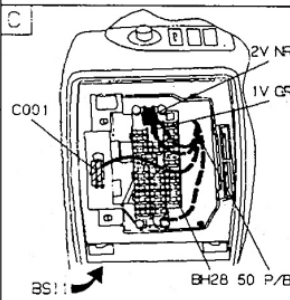
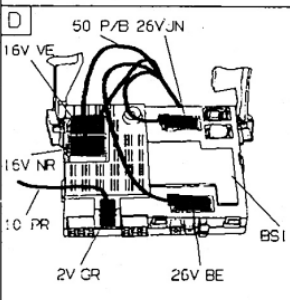
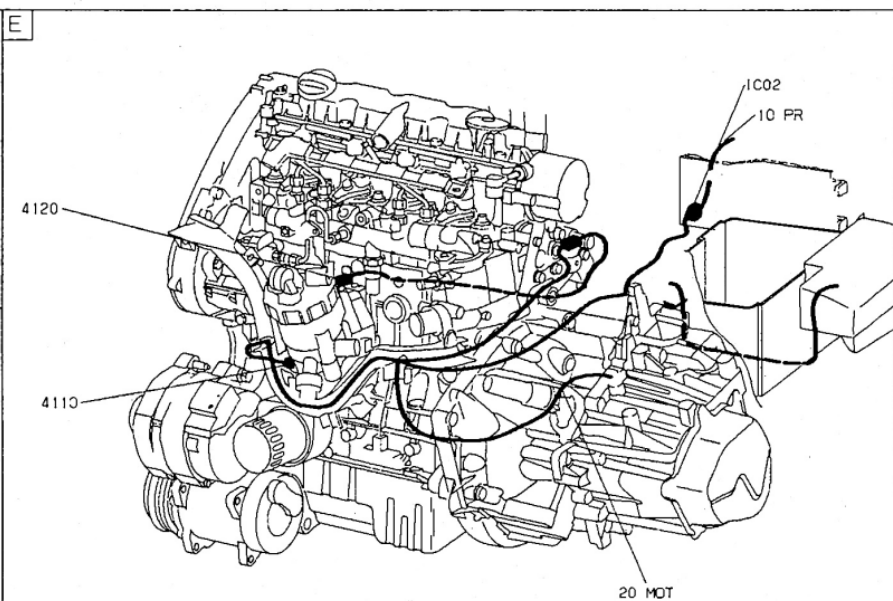
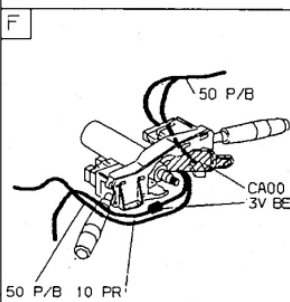
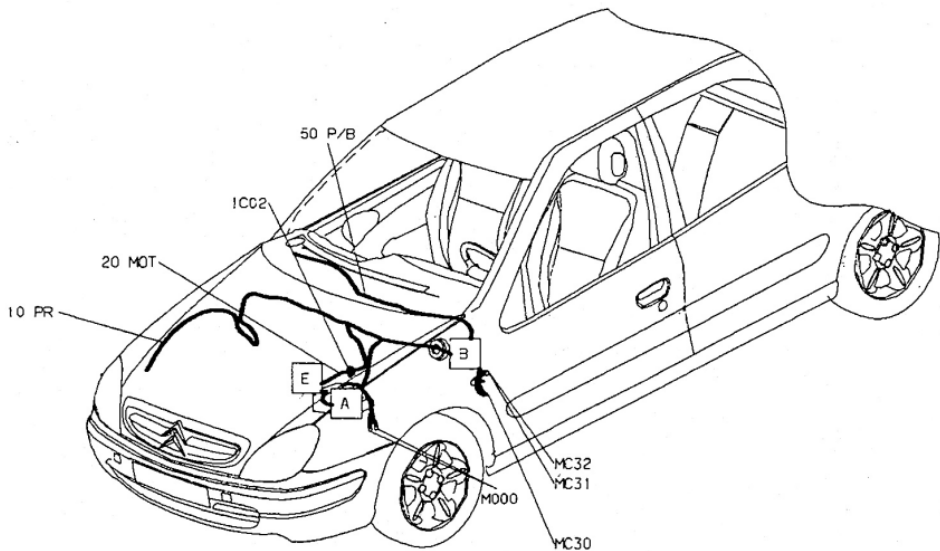

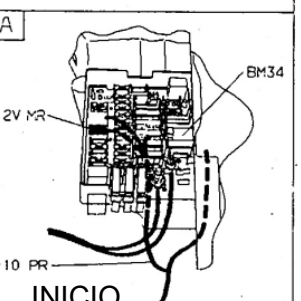
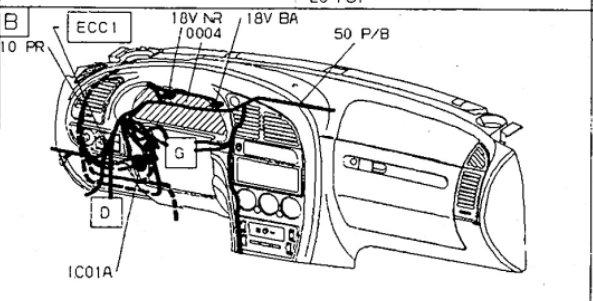
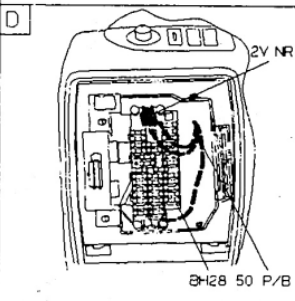
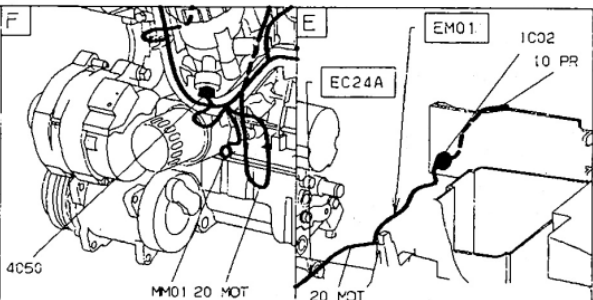
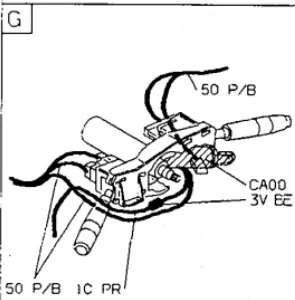
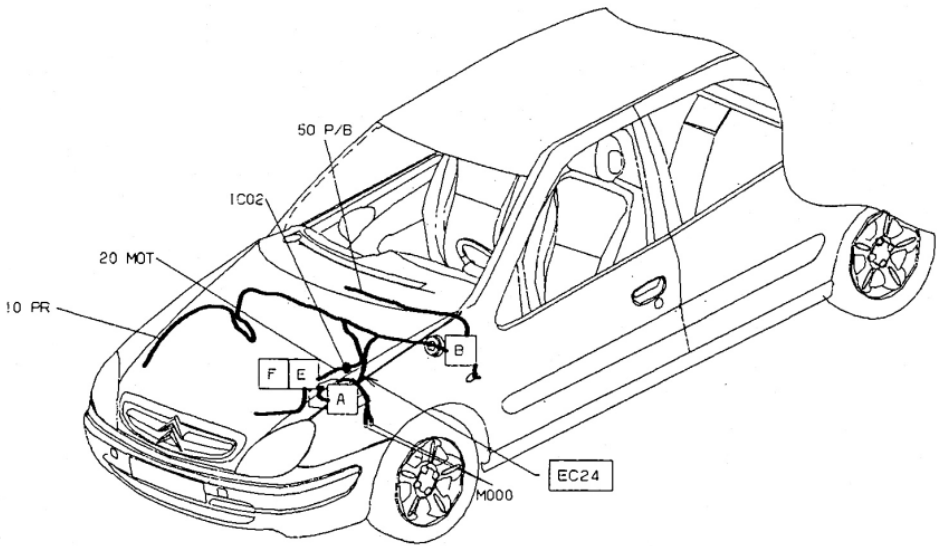

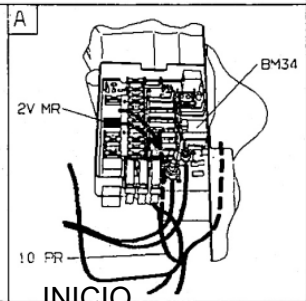
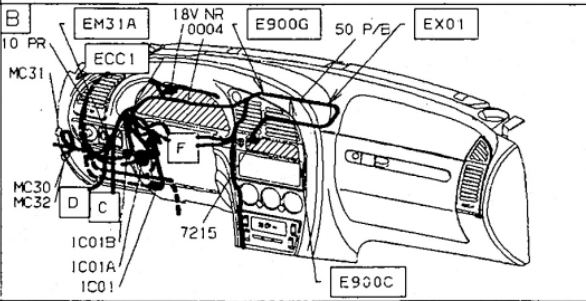
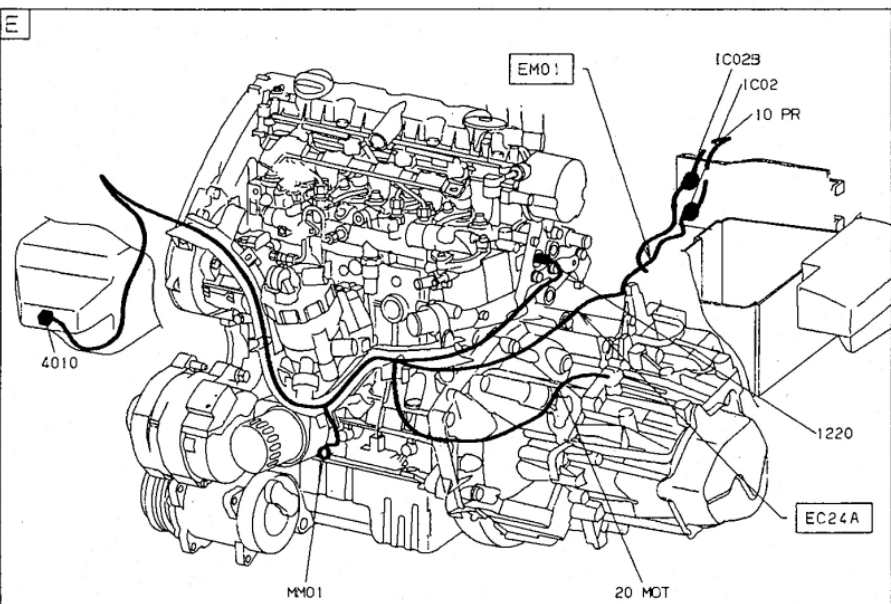
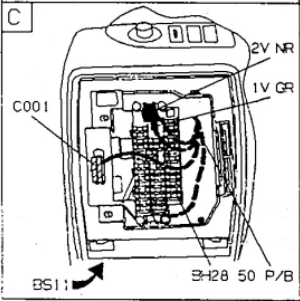
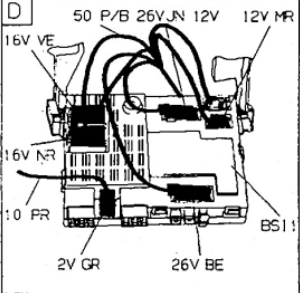
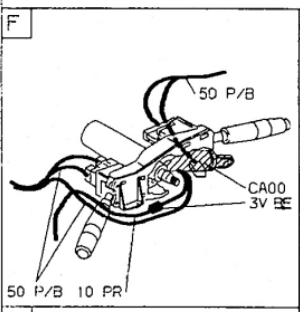
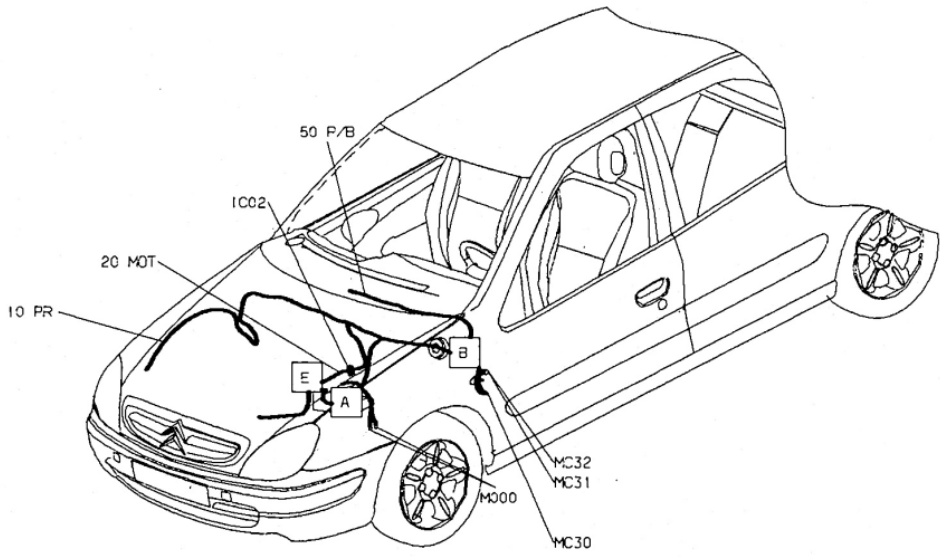

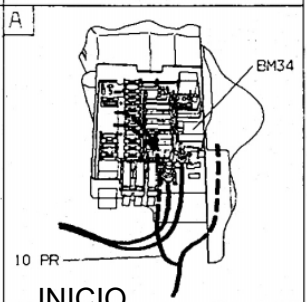
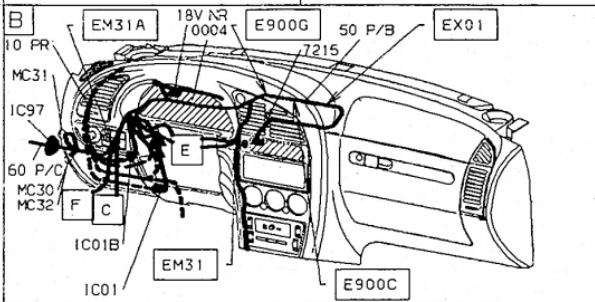
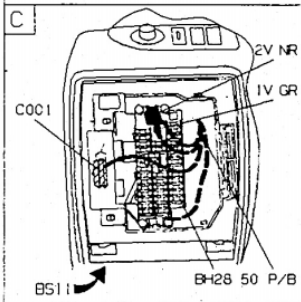
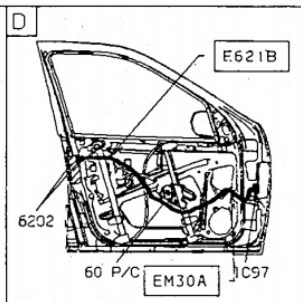
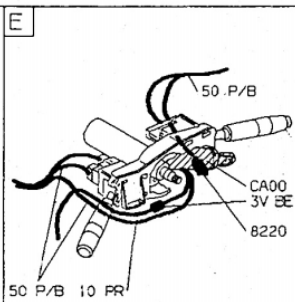
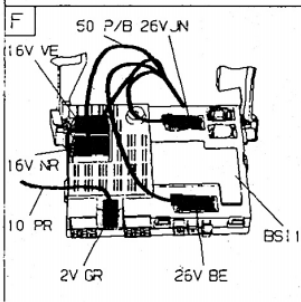
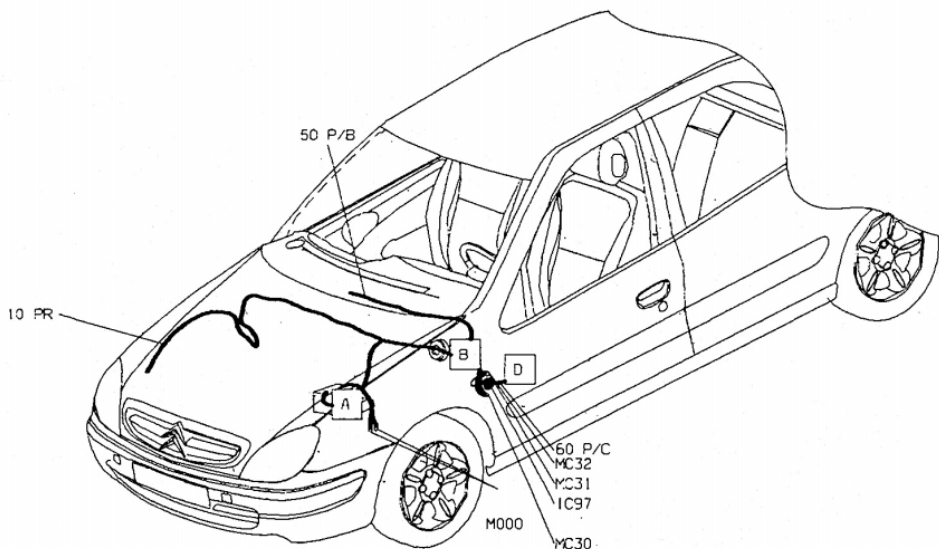

INICIO

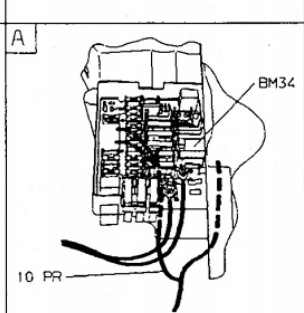
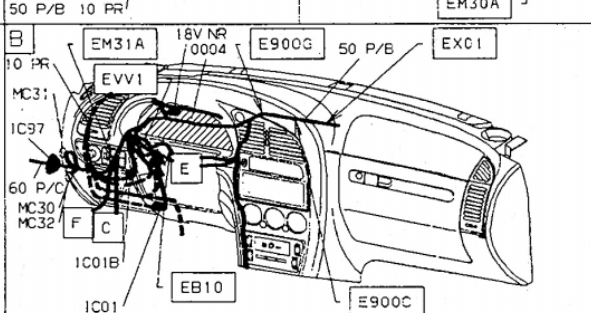
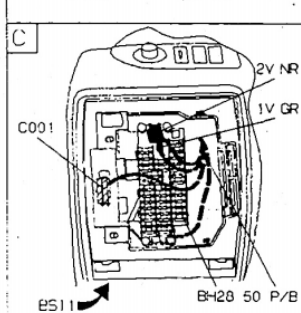
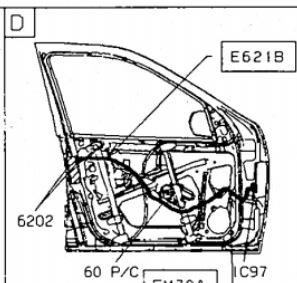
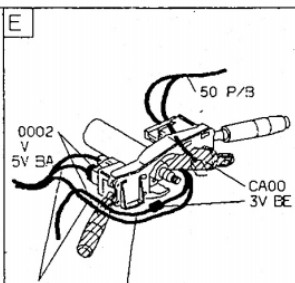
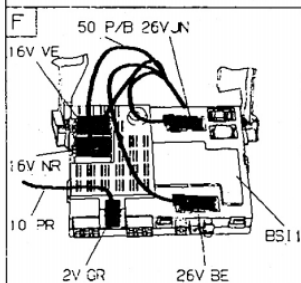
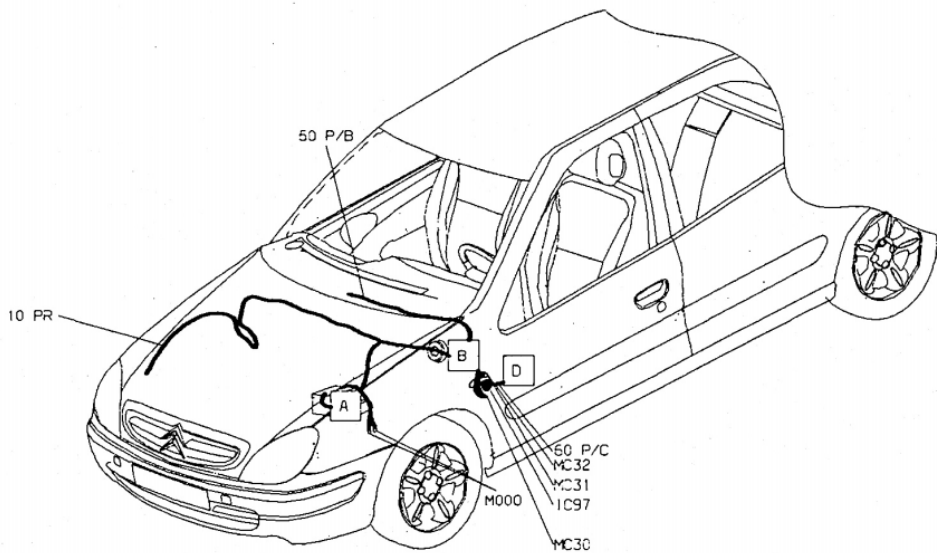

INICIO

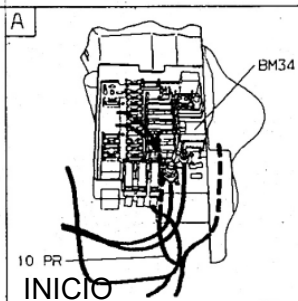
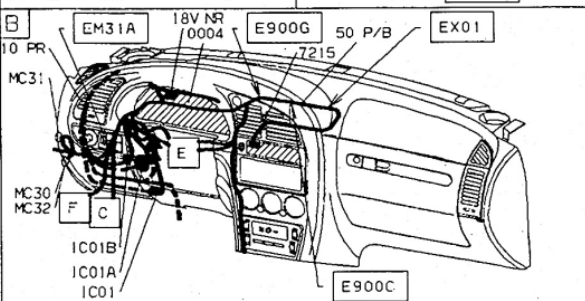
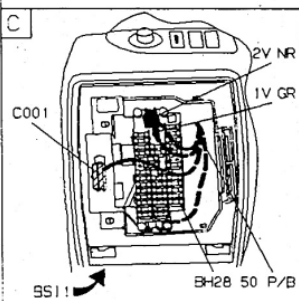
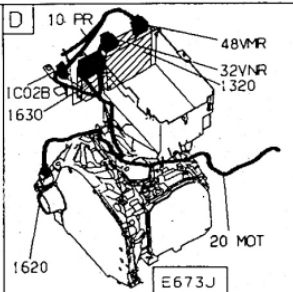
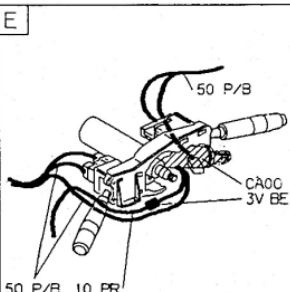
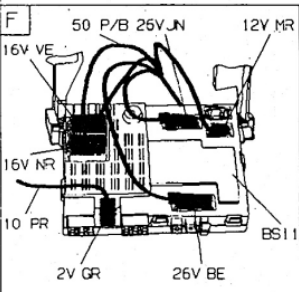
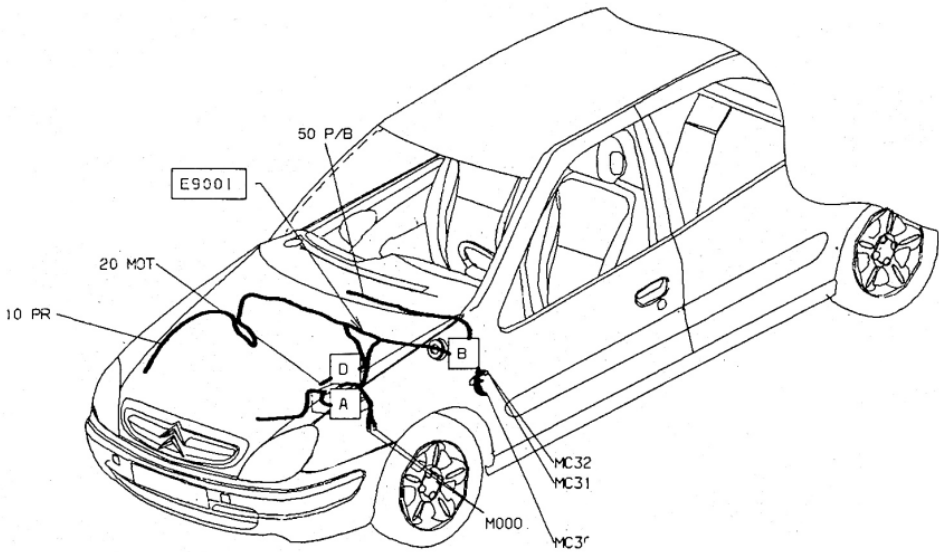

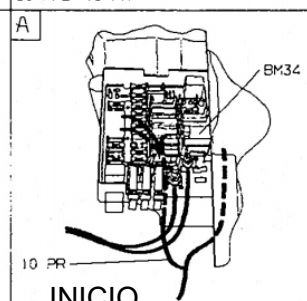
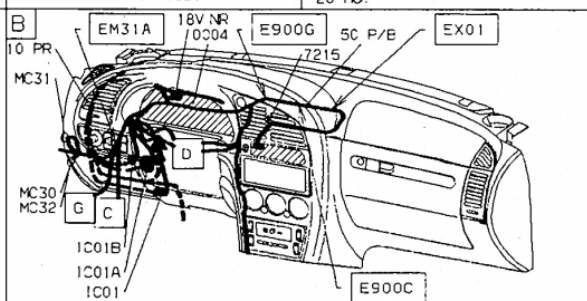
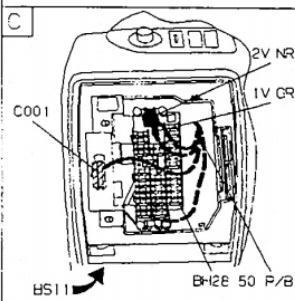
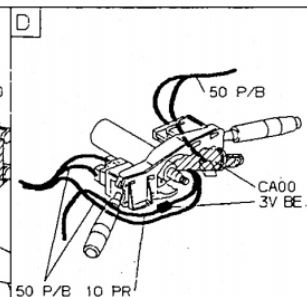
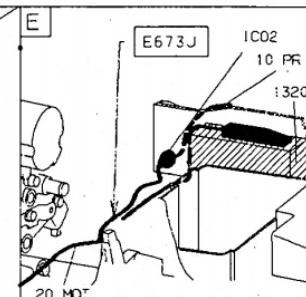
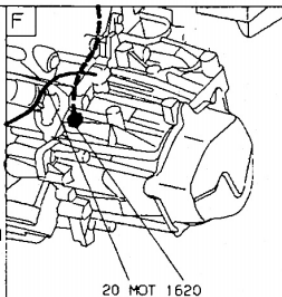
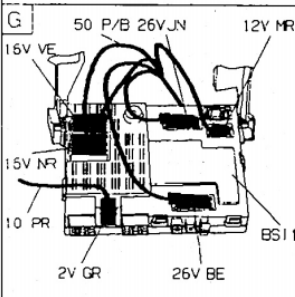
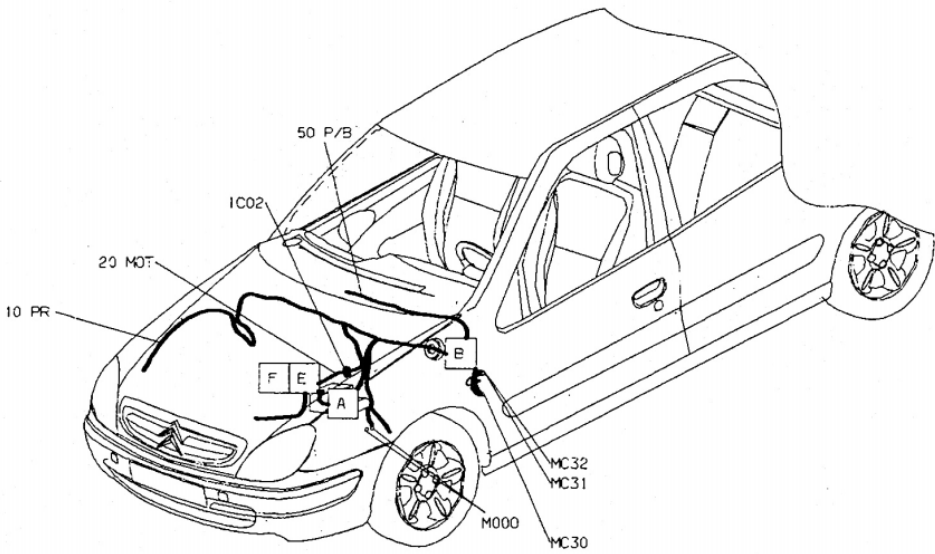

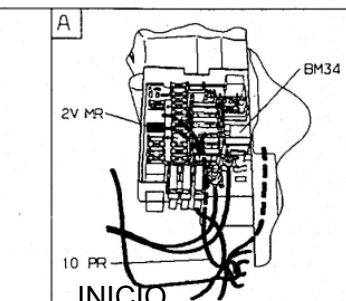
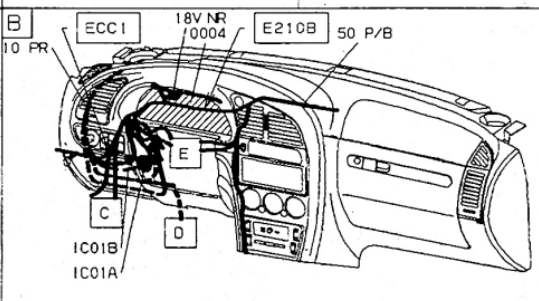
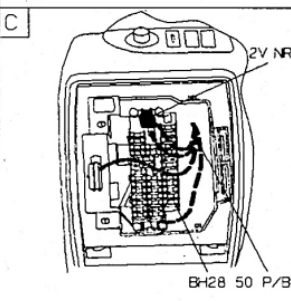
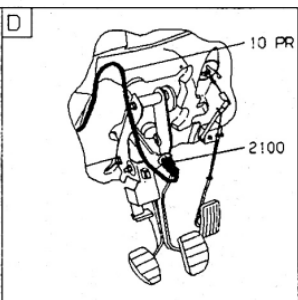
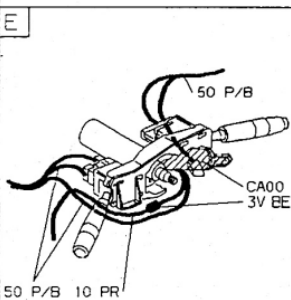
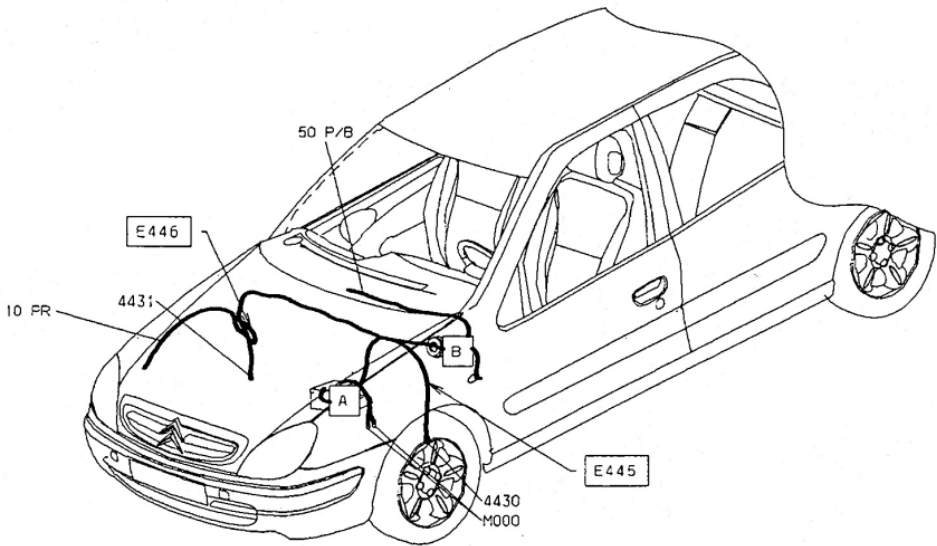

Axuda estacionamento

3 portas

5 portas

Break

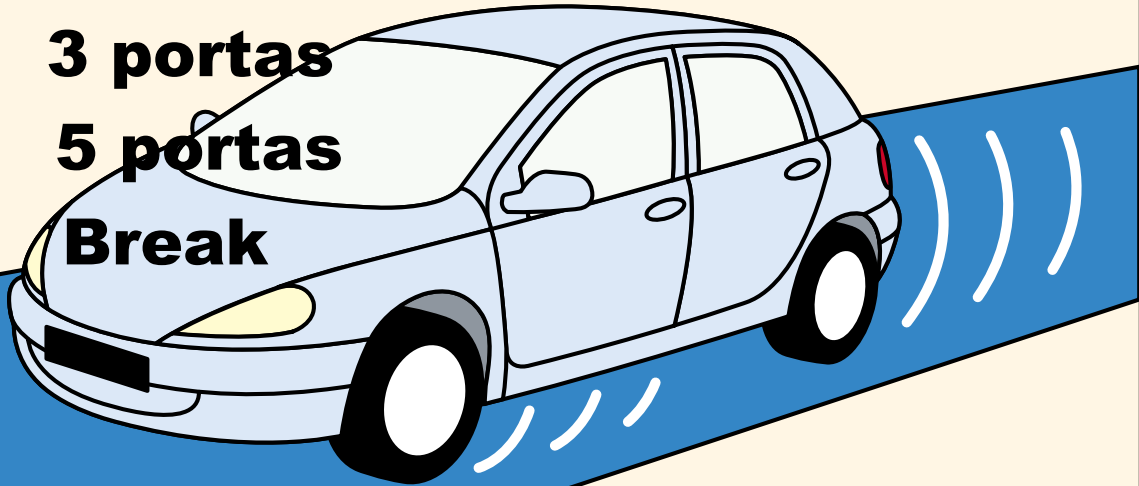

INICIO

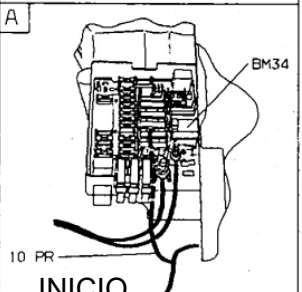
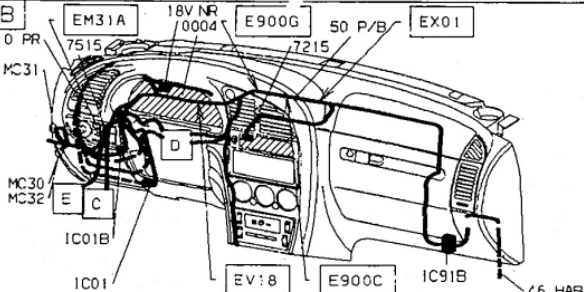
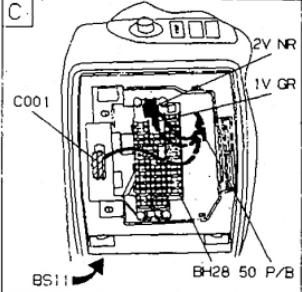
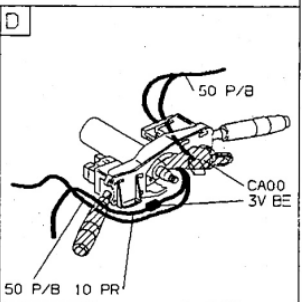
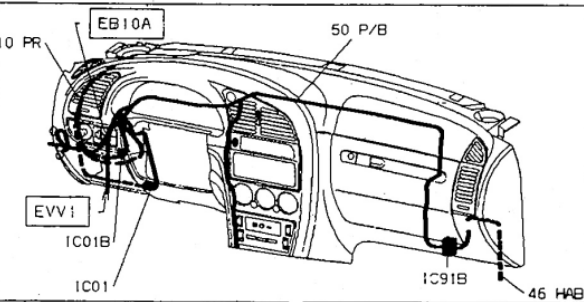
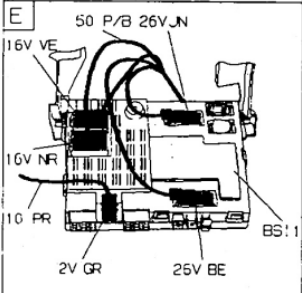
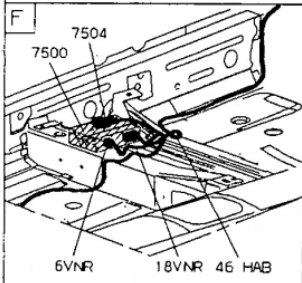
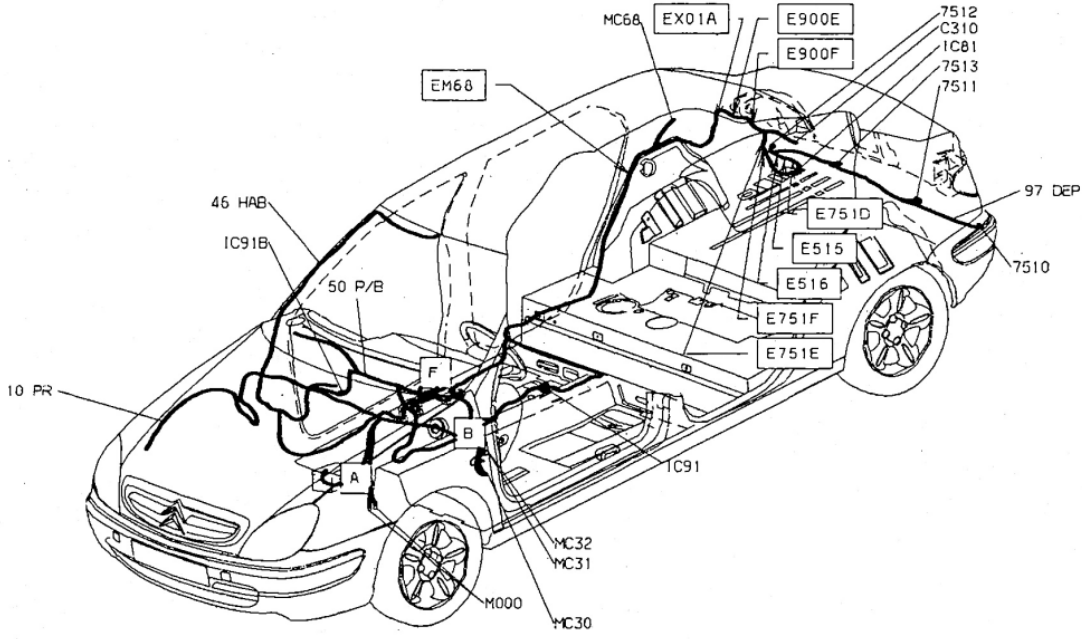

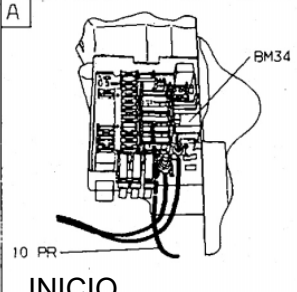
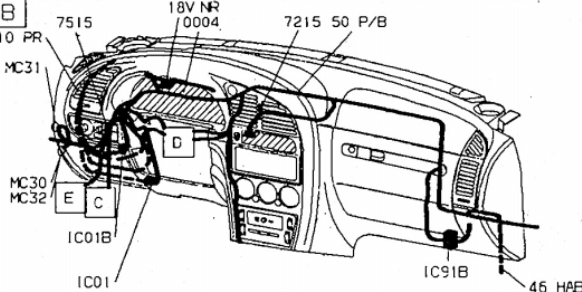
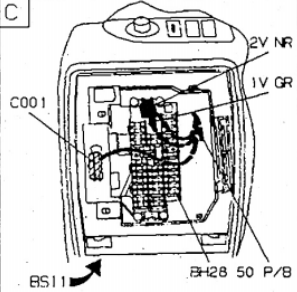
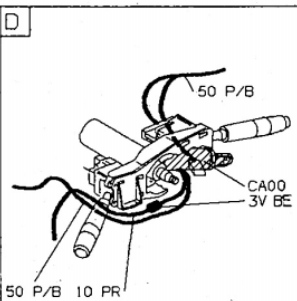
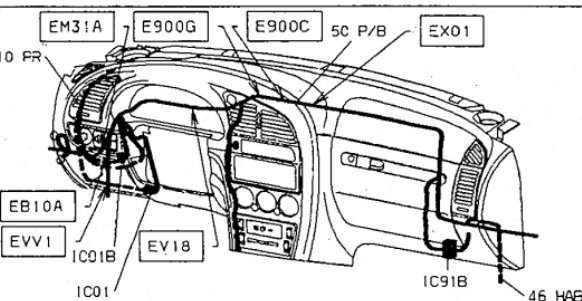
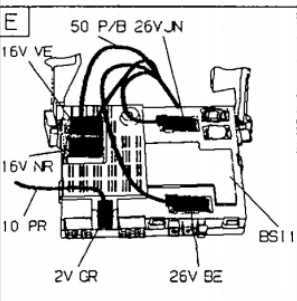
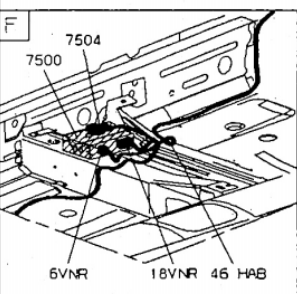
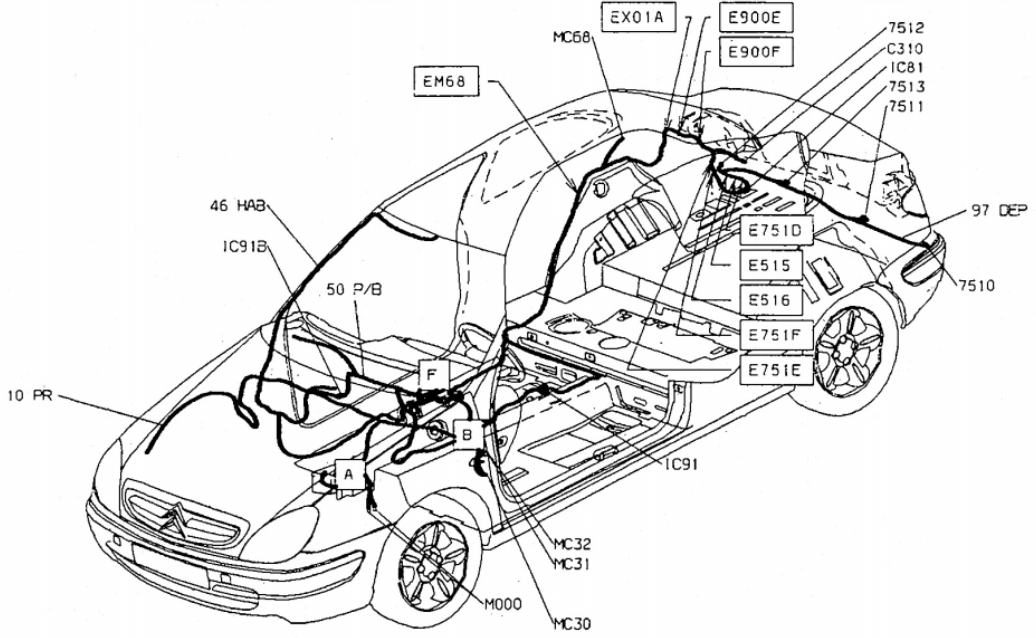

INICIO

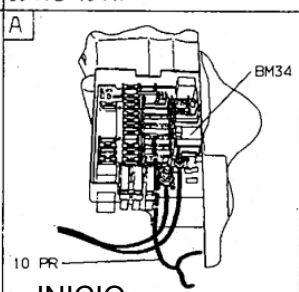
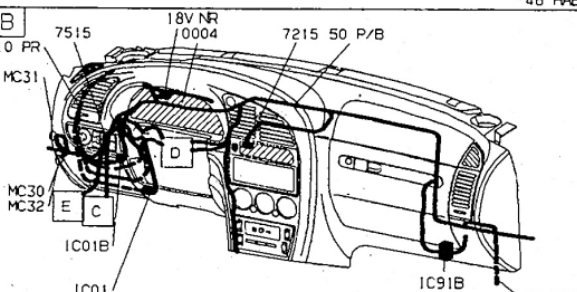
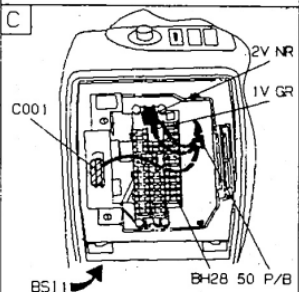
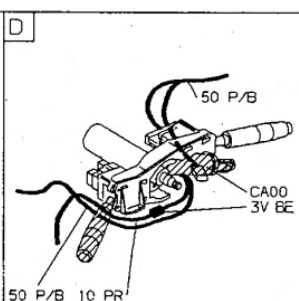
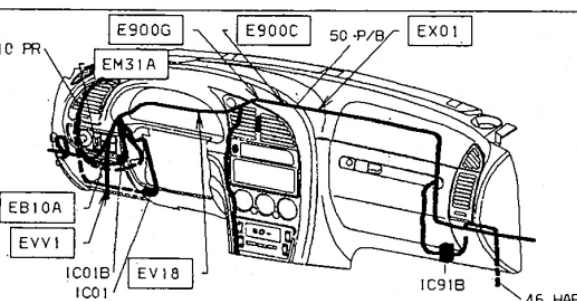
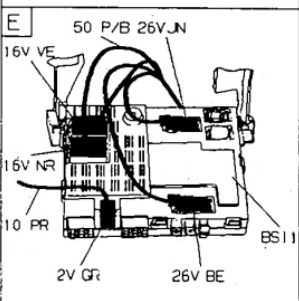
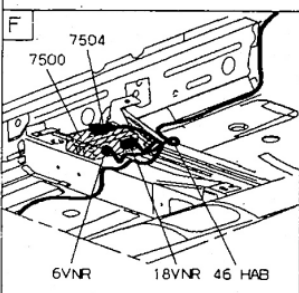
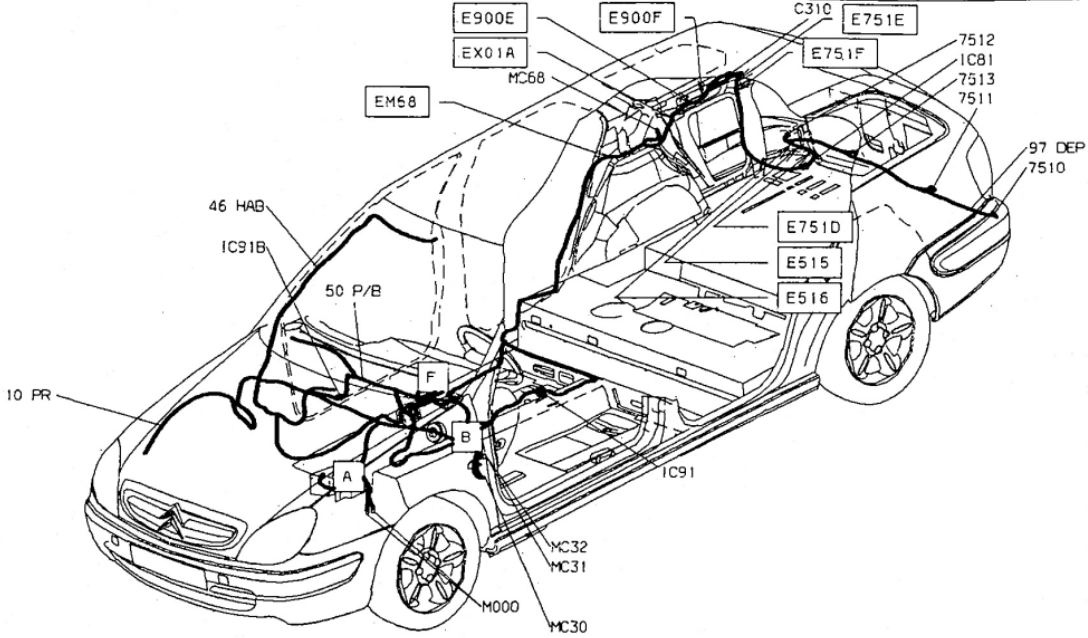

INICIO

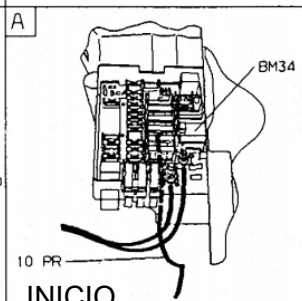
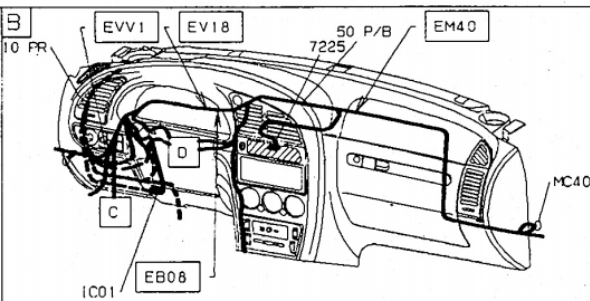
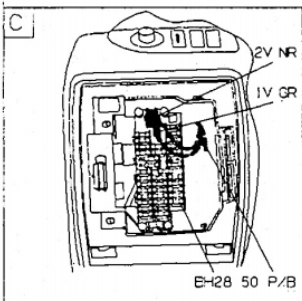
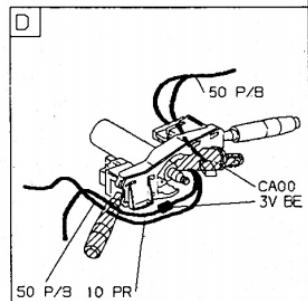
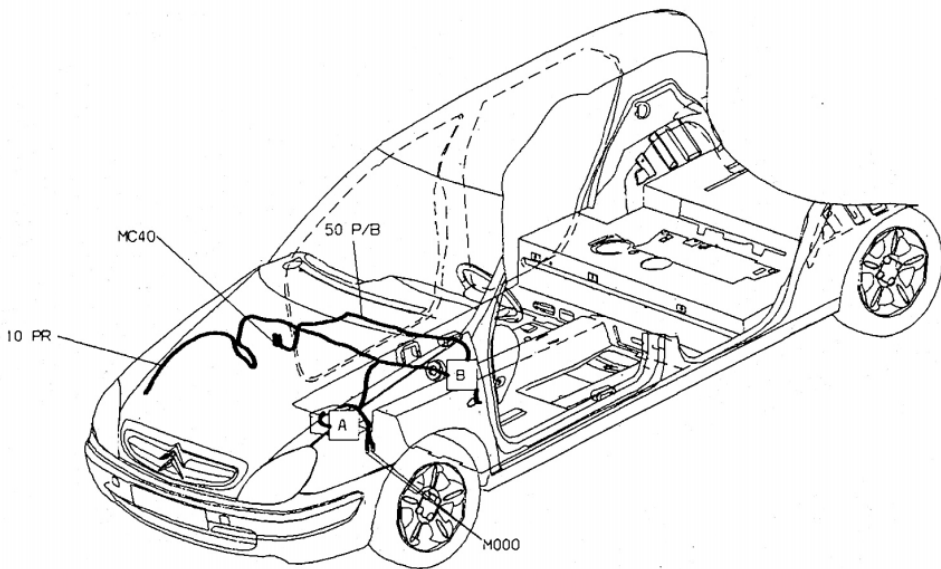

INICIO

Ordenador de abordo

Cambio manual

Cambio automático



INICIO

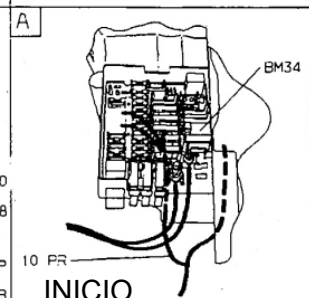
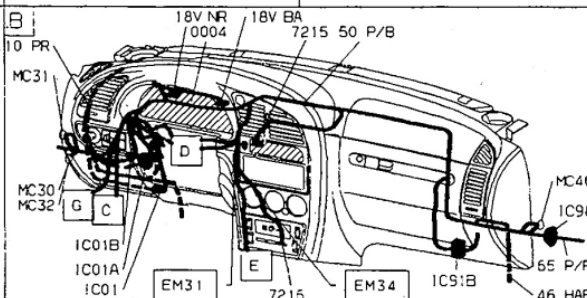
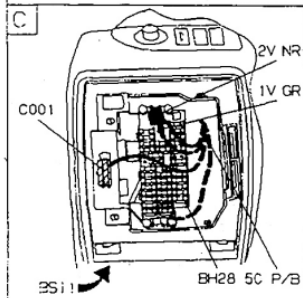
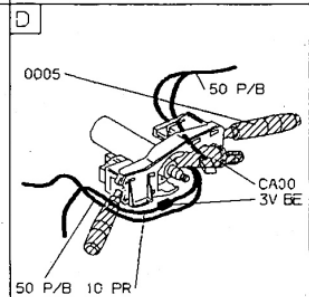
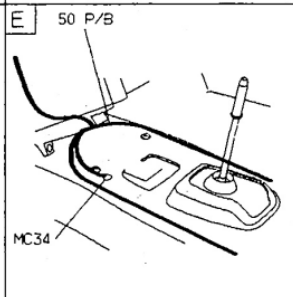
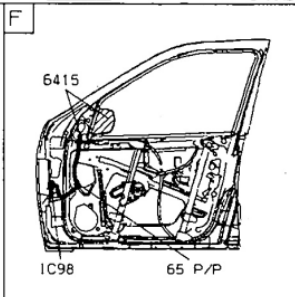
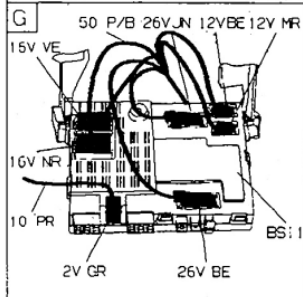
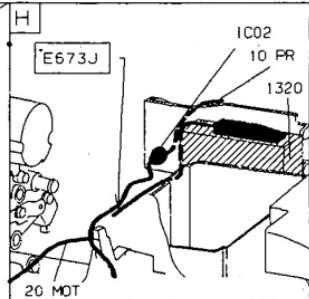
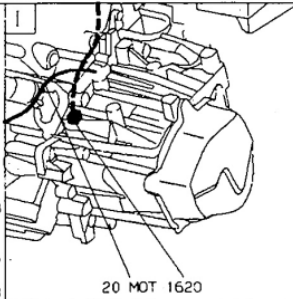
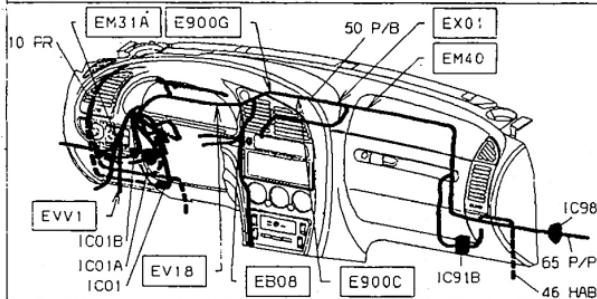
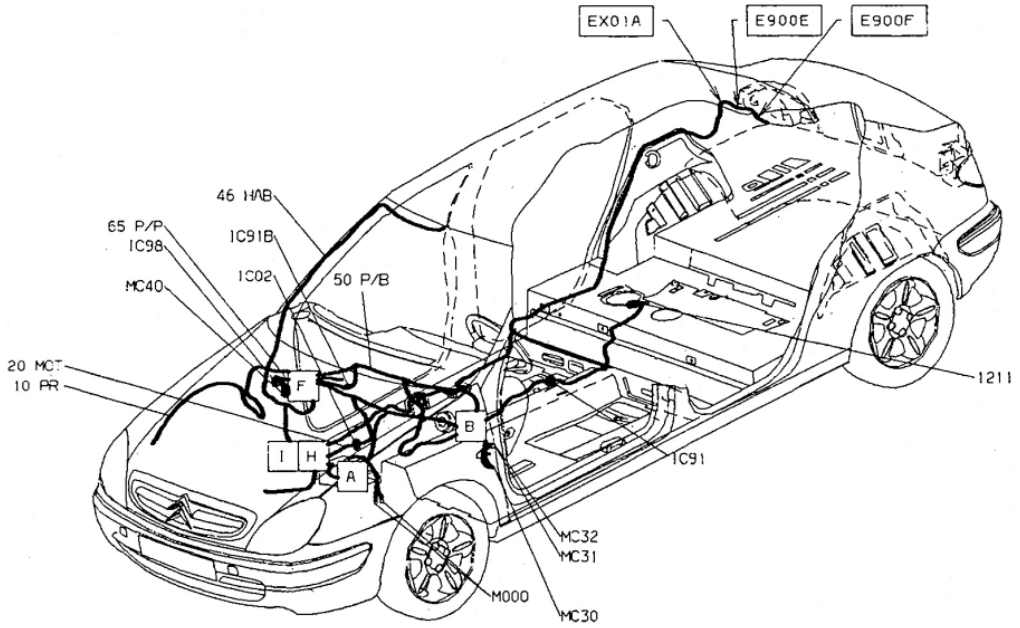

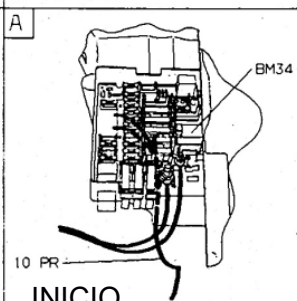
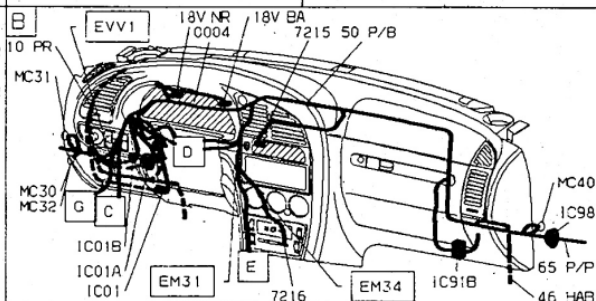
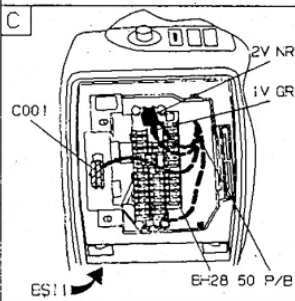
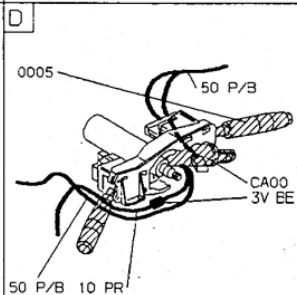
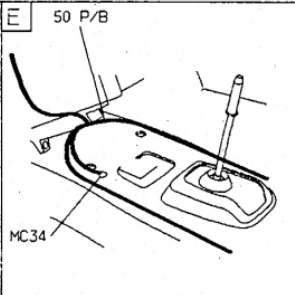
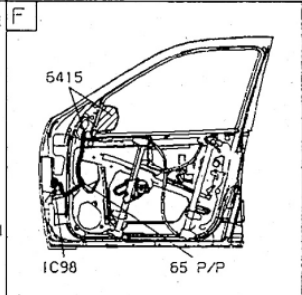
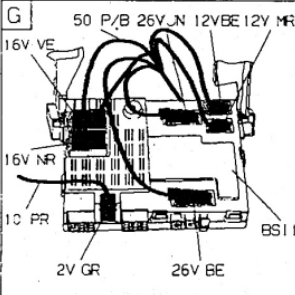
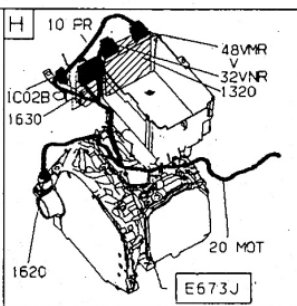
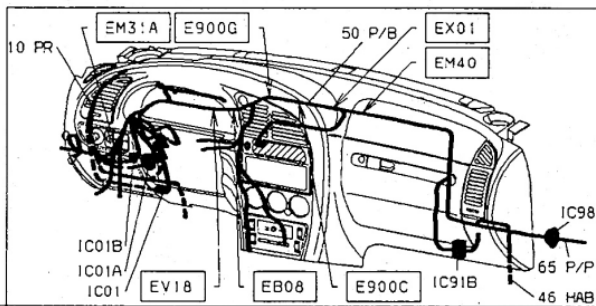
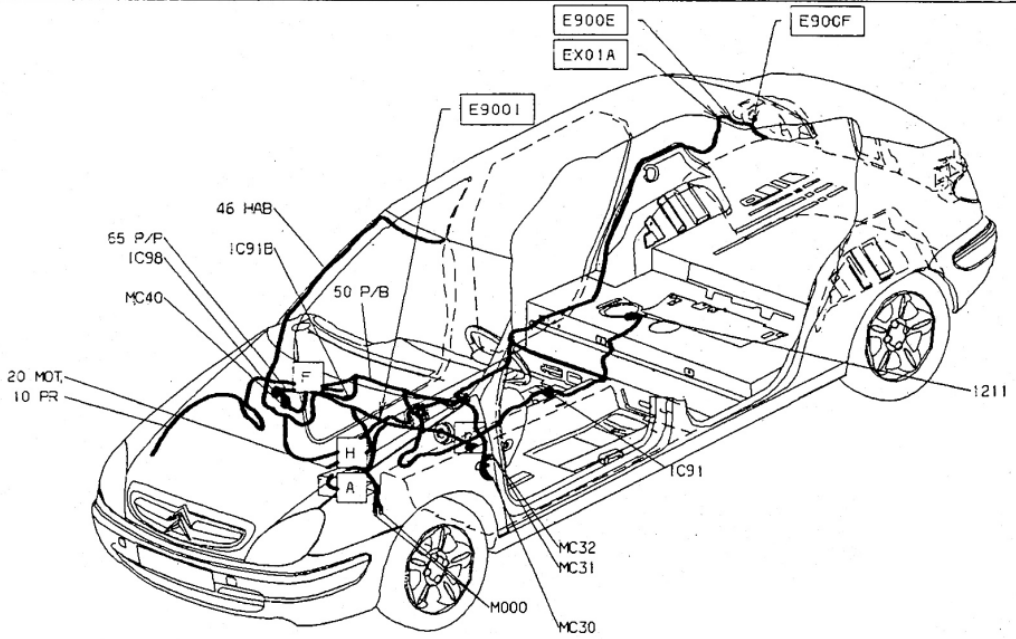

INICIO

SEGURIDADE

Airbags e pretensores

Antiarranque con caixa automática

Antiarranque



INICIO

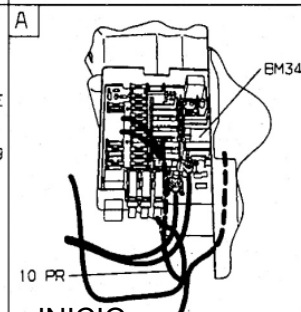
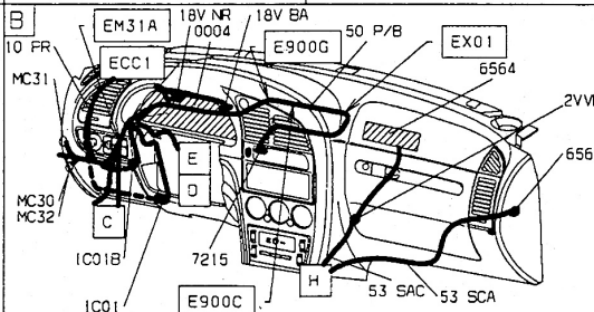
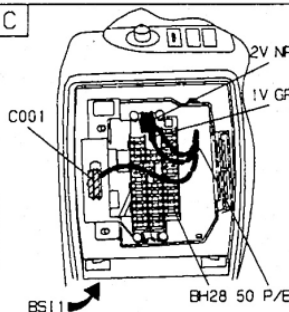
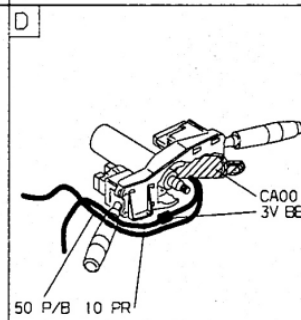
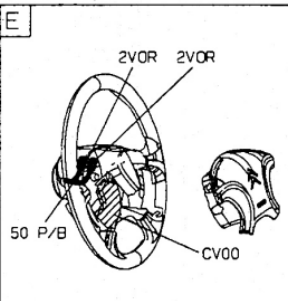
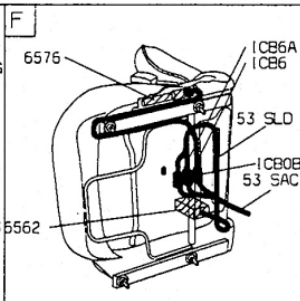
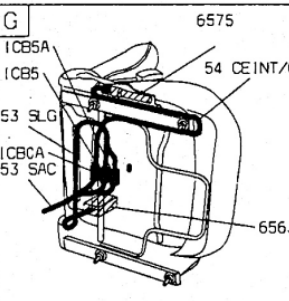
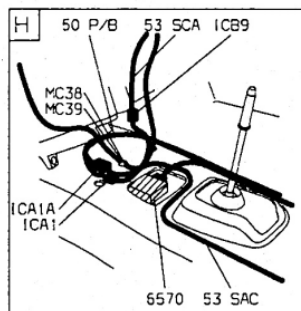
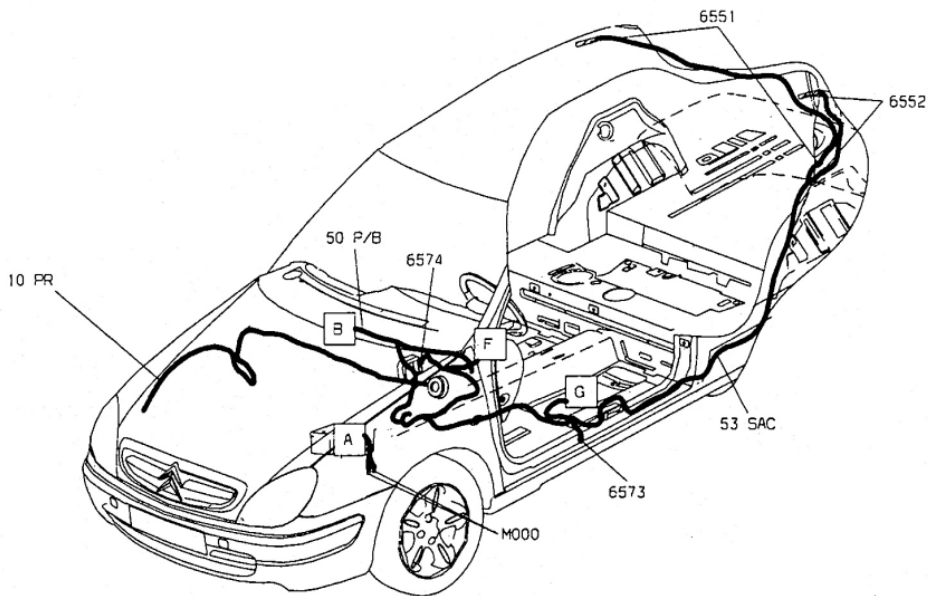

INICIO

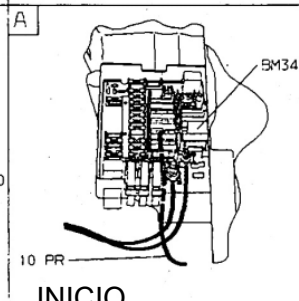
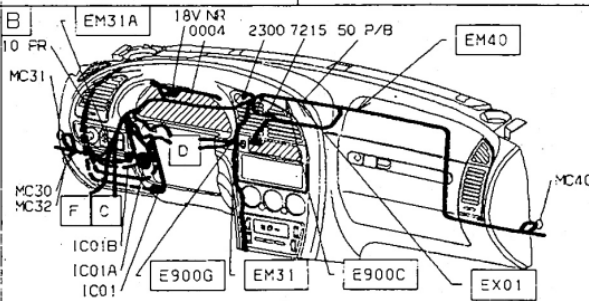
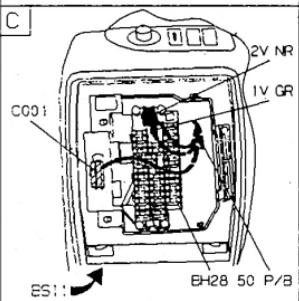
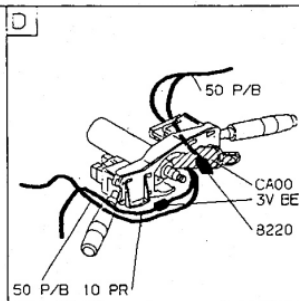
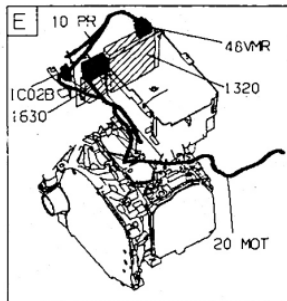
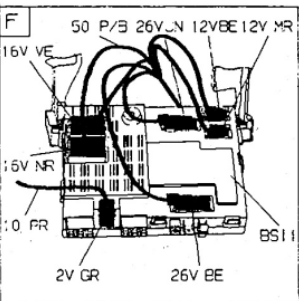
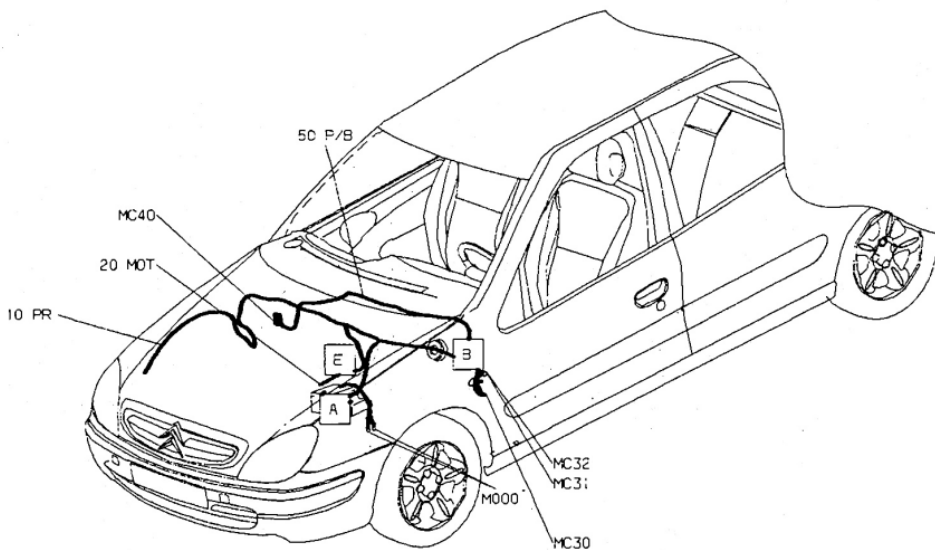

INICIO

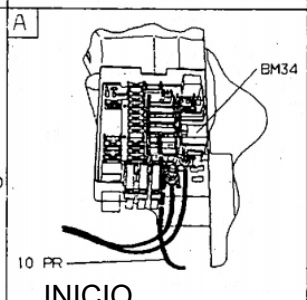
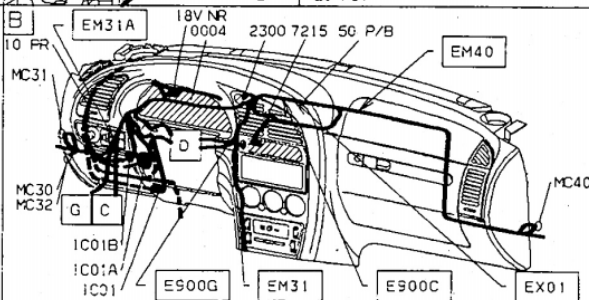
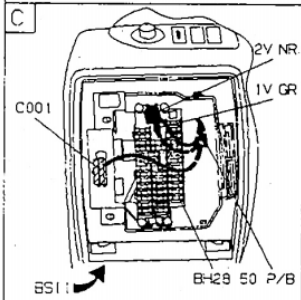
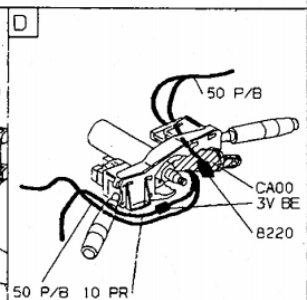
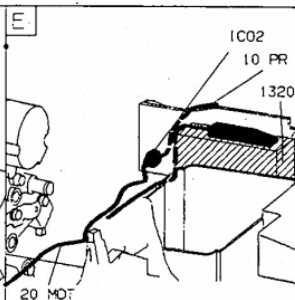
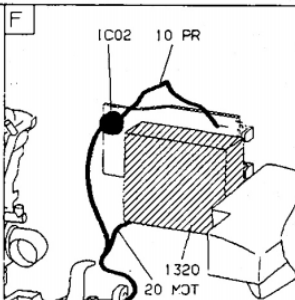
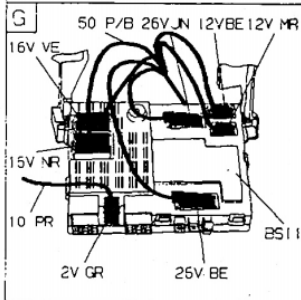
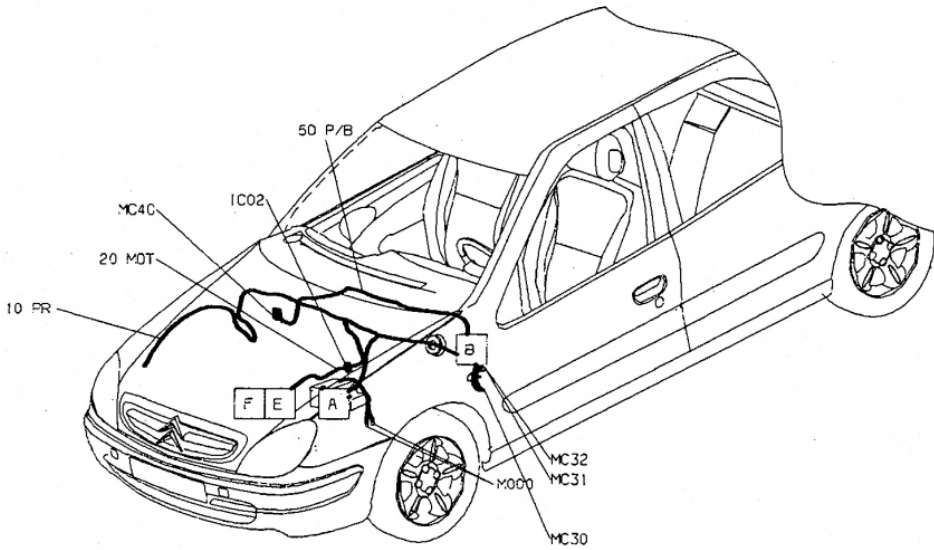

INICIO

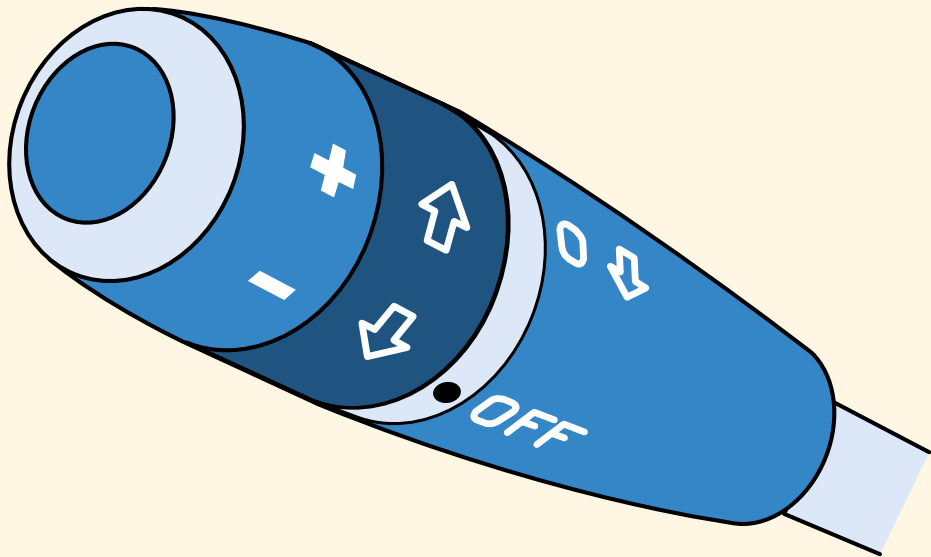

INICIO

Peche centralizado



INICIO

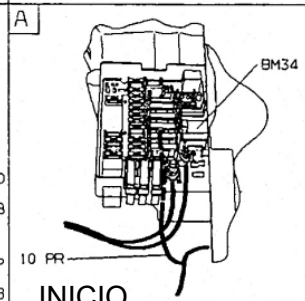
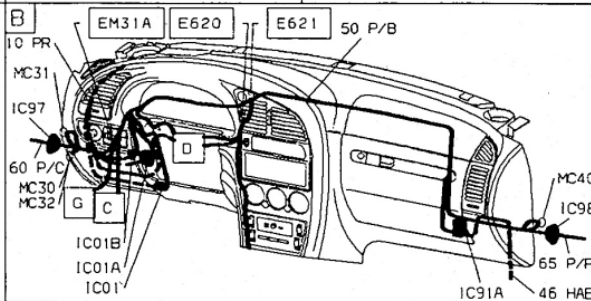
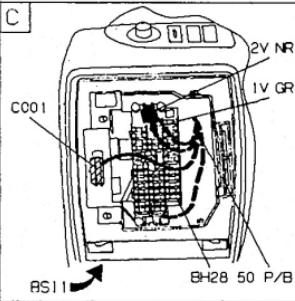
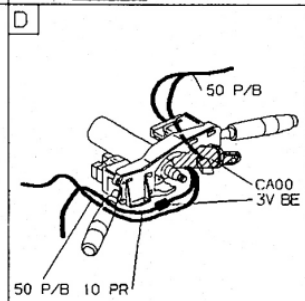
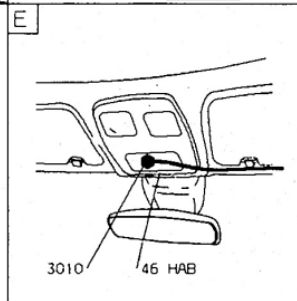
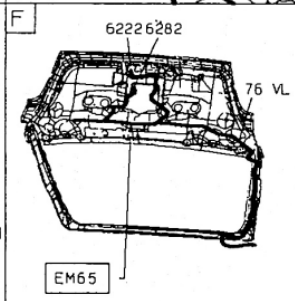
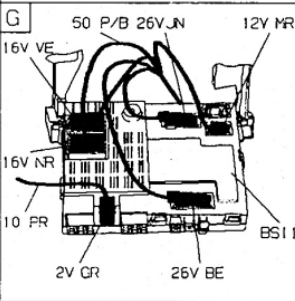
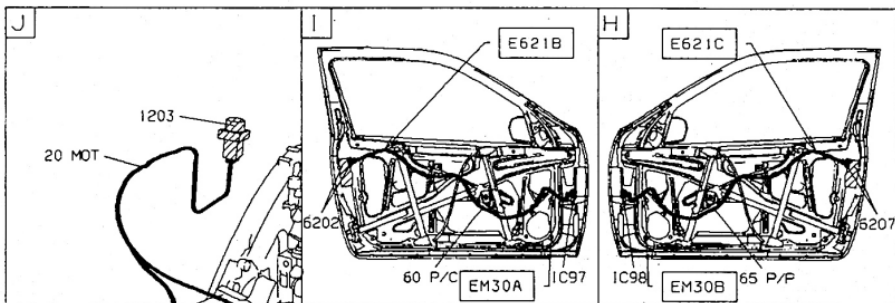
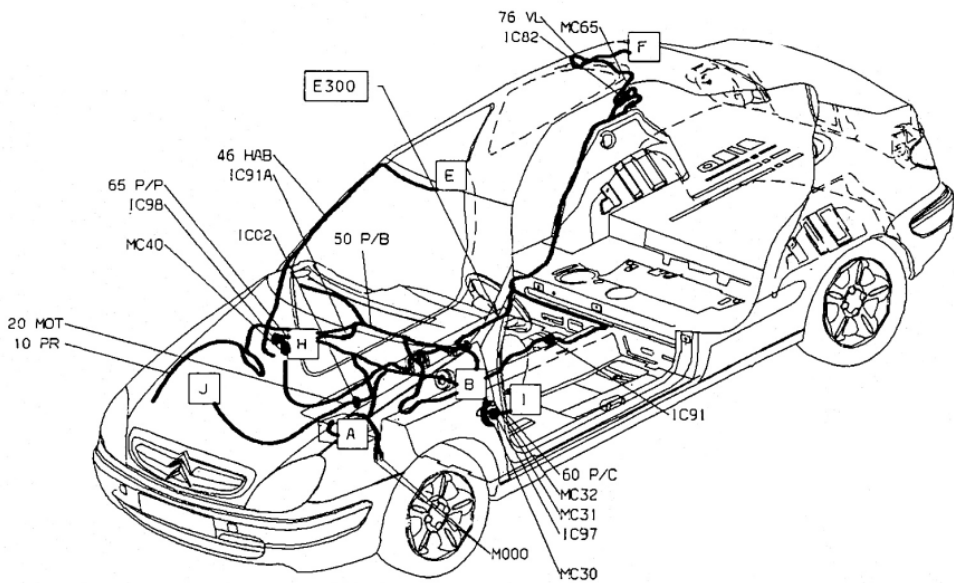

INICIO

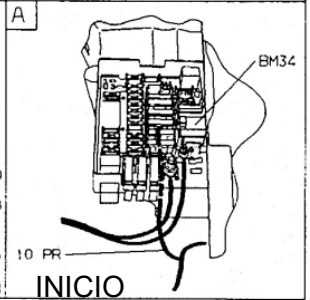
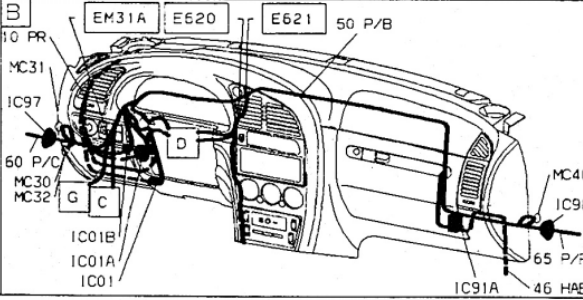
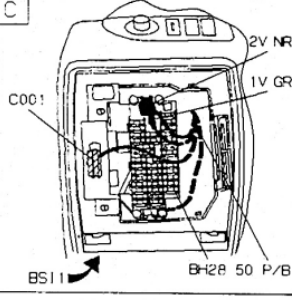
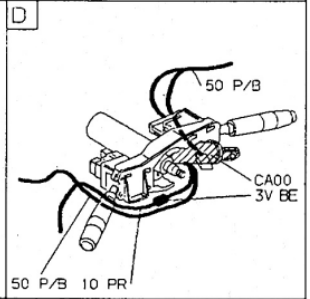
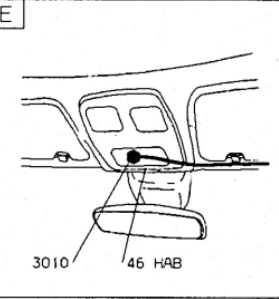
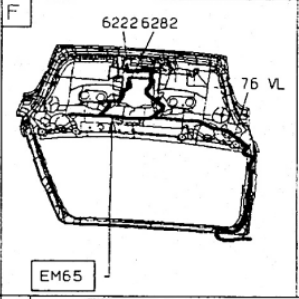
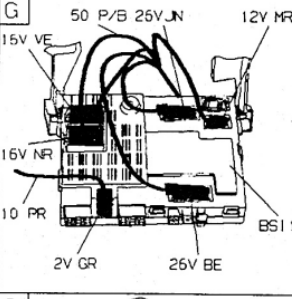
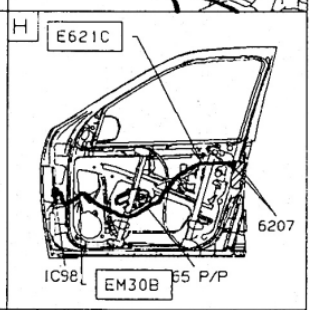
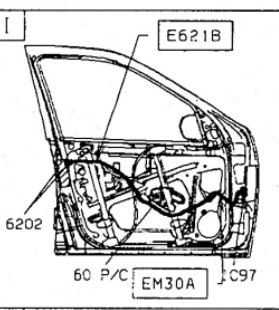
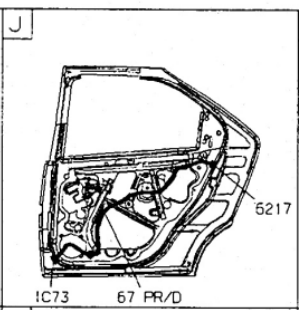
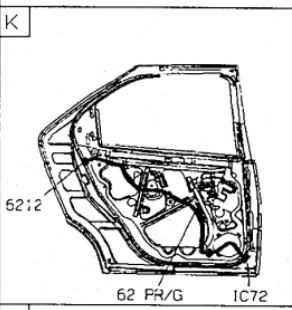
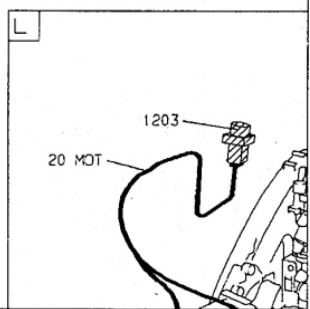
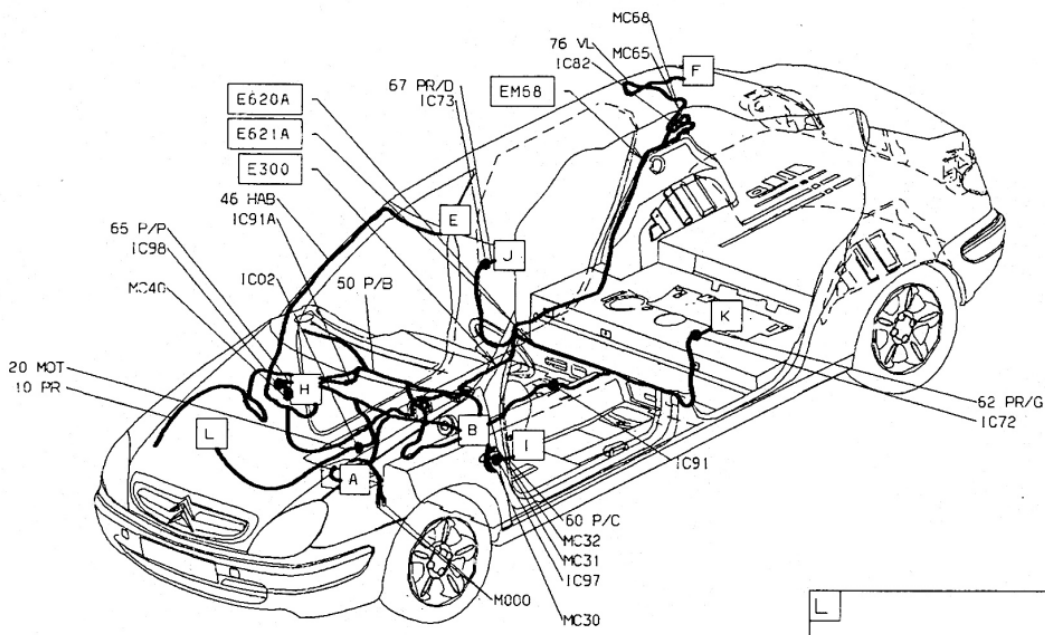

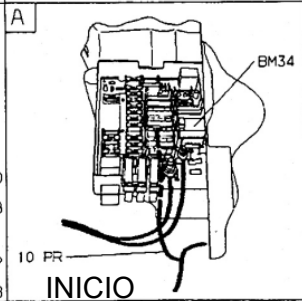
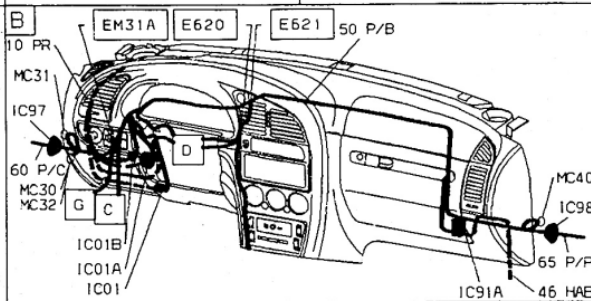
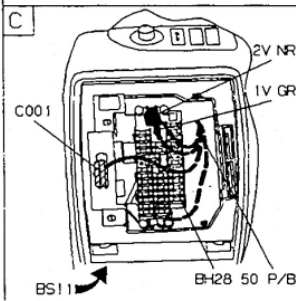
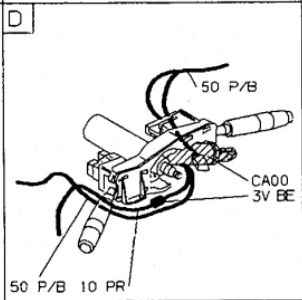
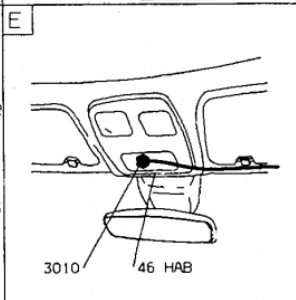
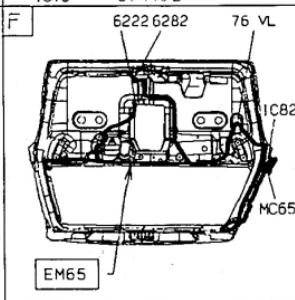
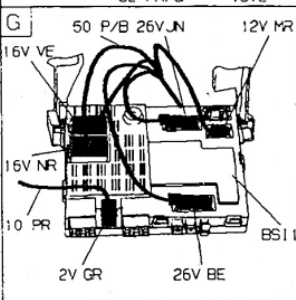
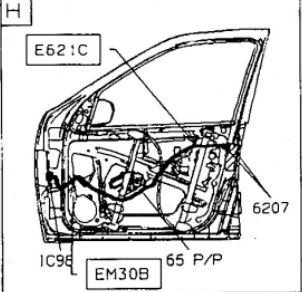
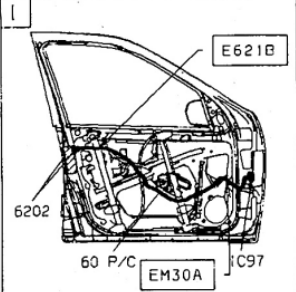
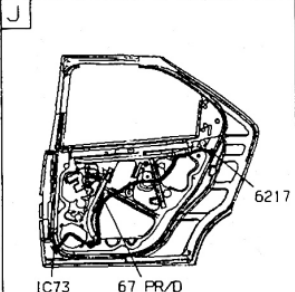
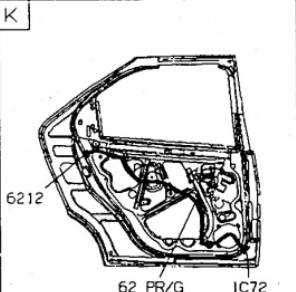
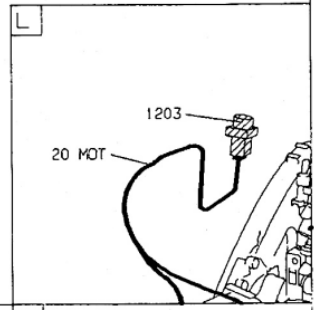
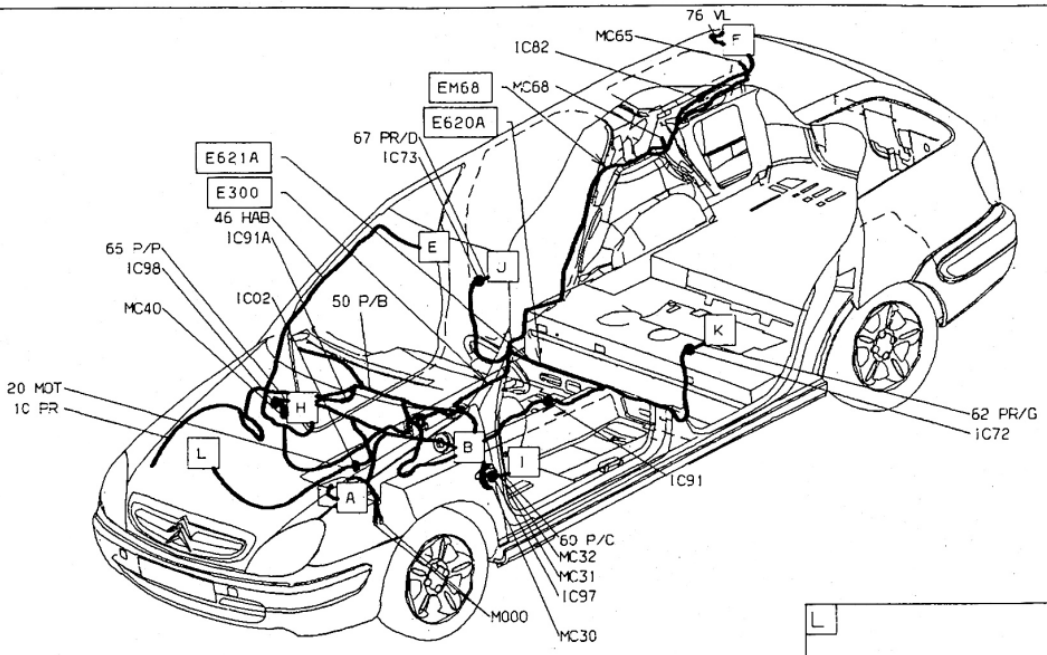

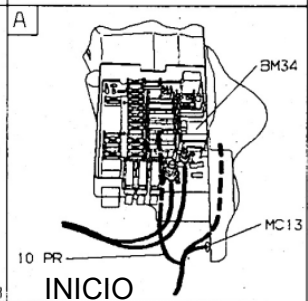
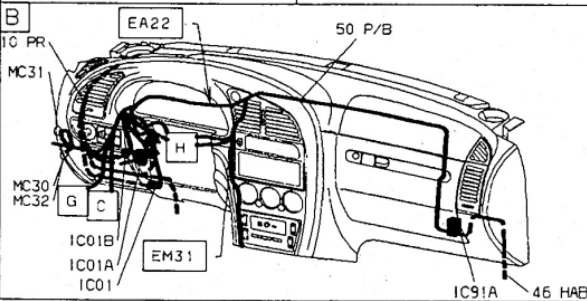
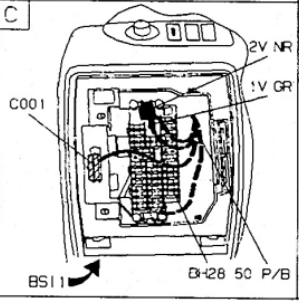
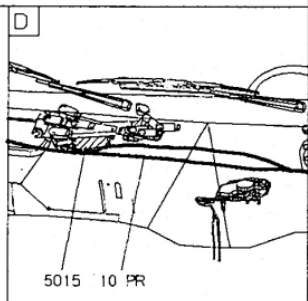
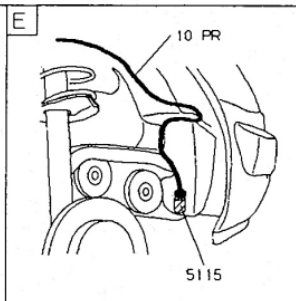
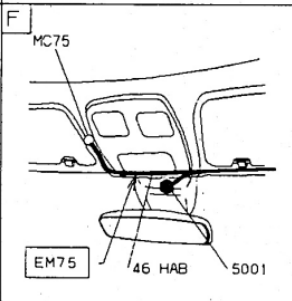
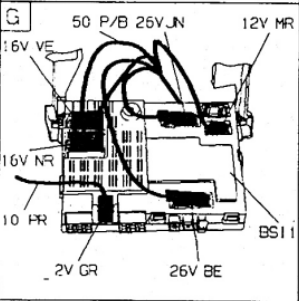
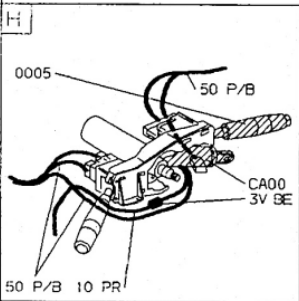
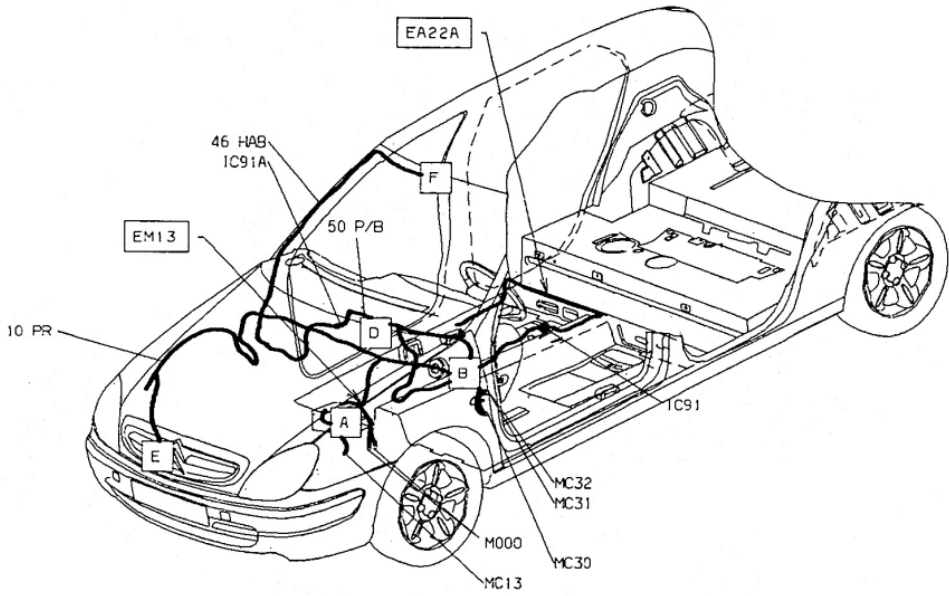

Limpa e lavaluvas traseiro

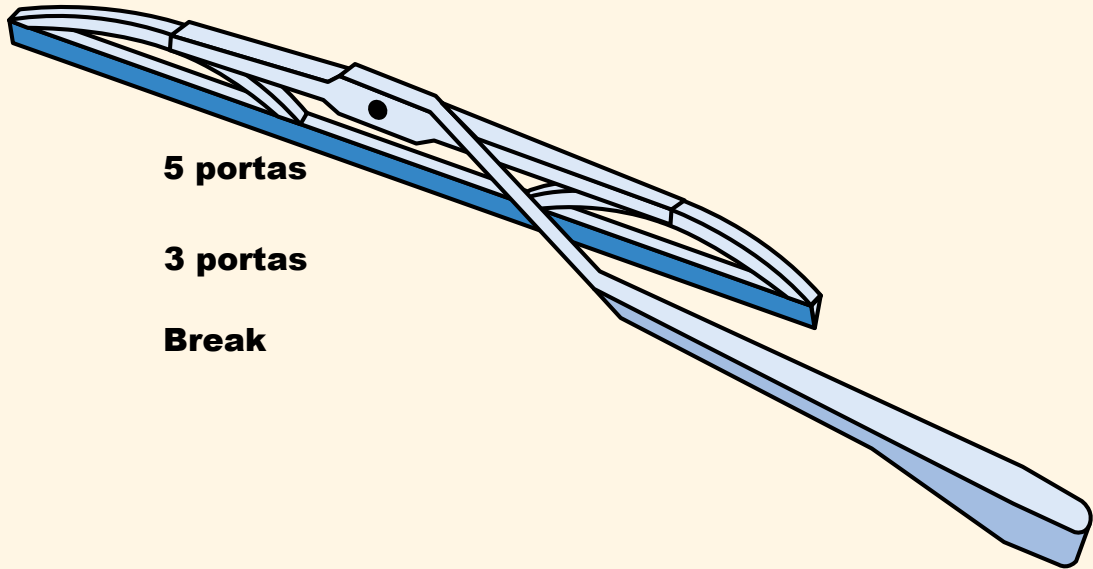

5 portas

3 portas

Break

INICIO

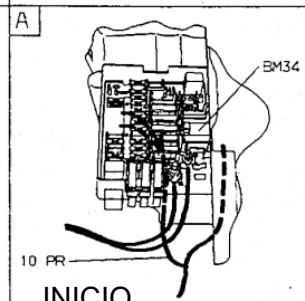
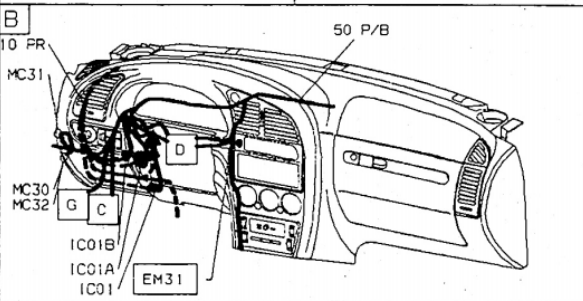
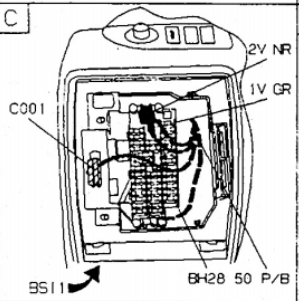
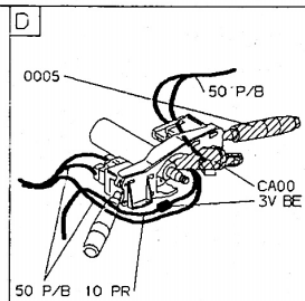
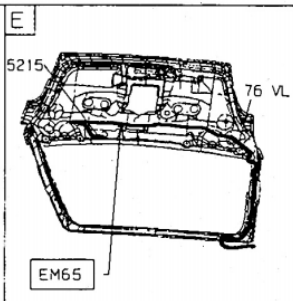
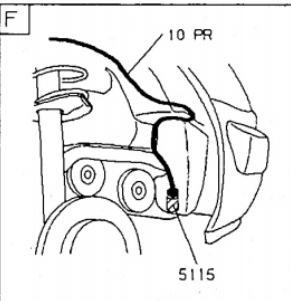
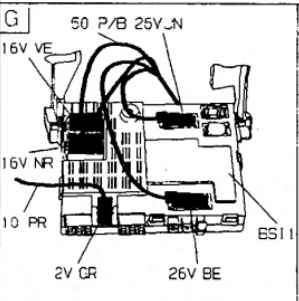
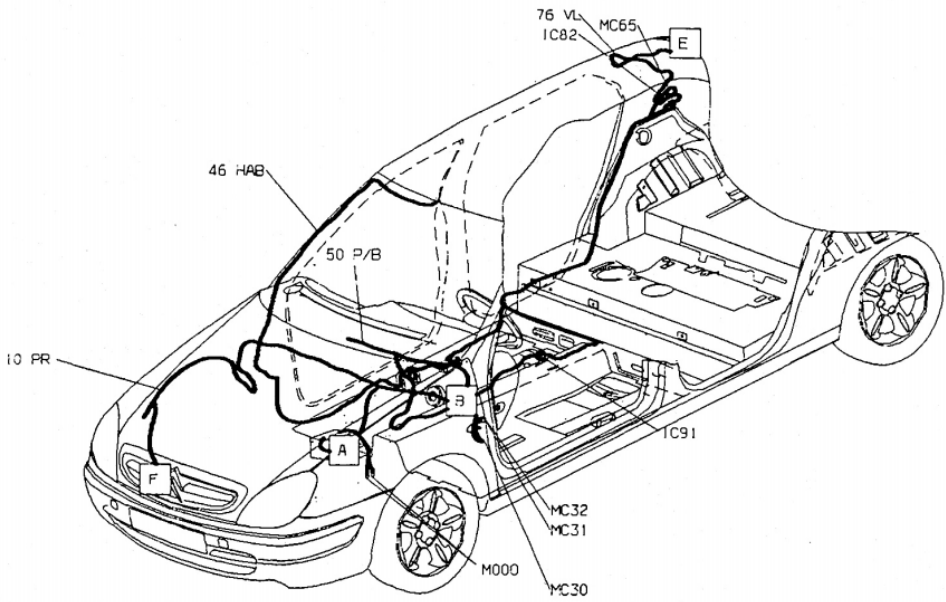

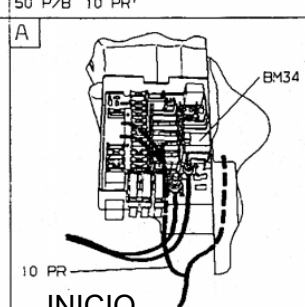
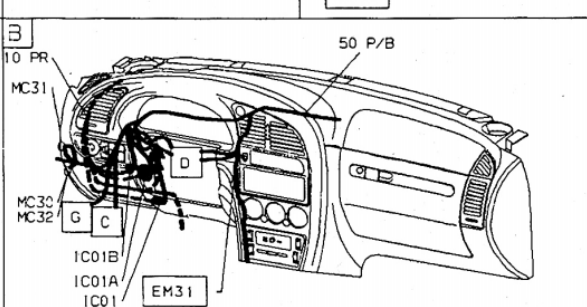
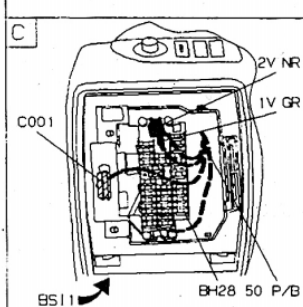
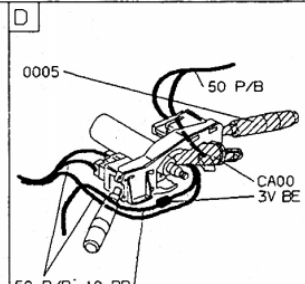
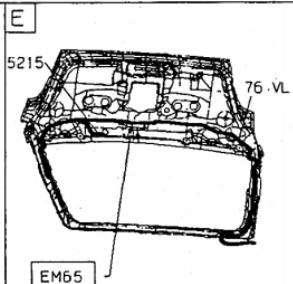
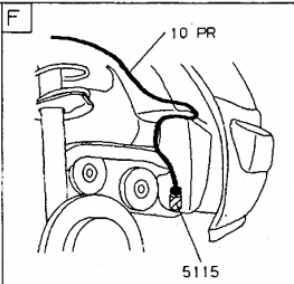
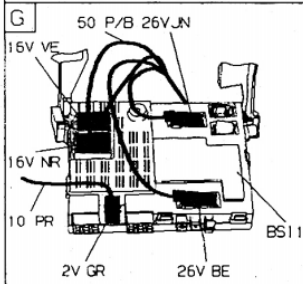
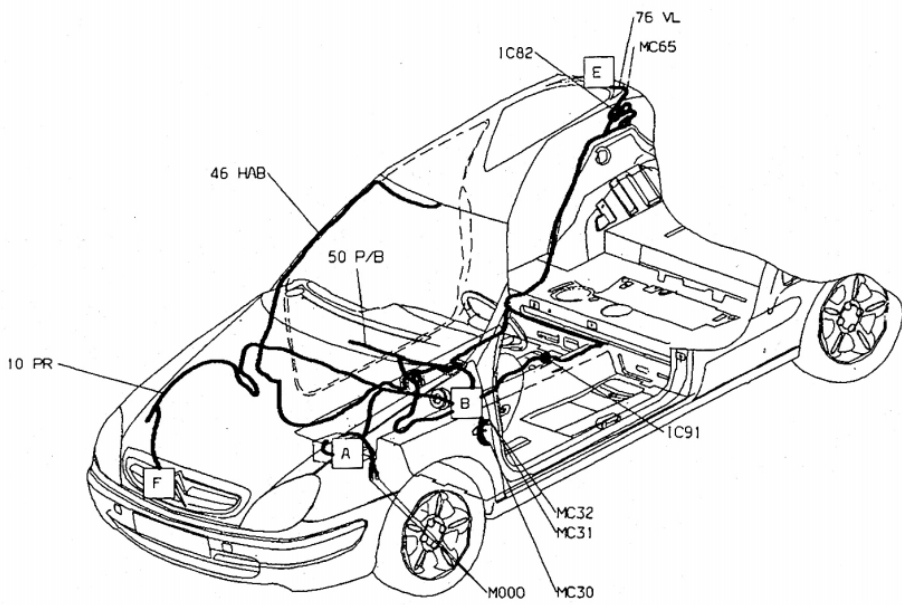

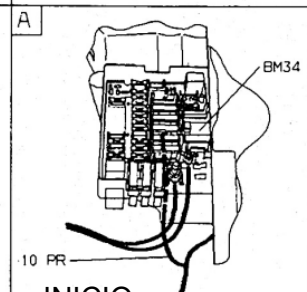
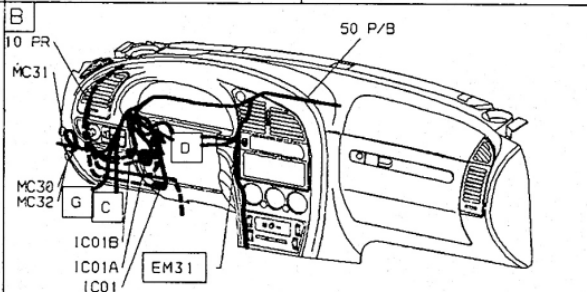
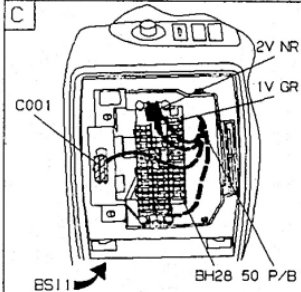
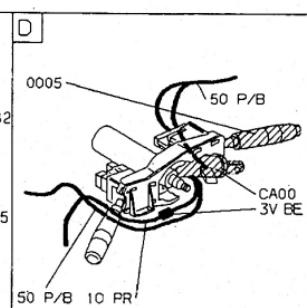
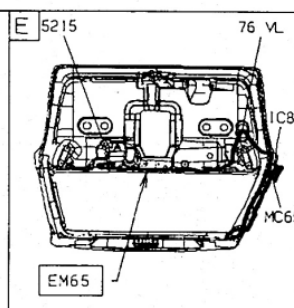
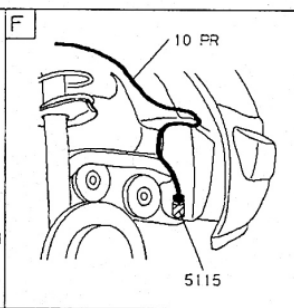
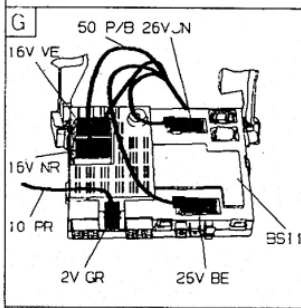
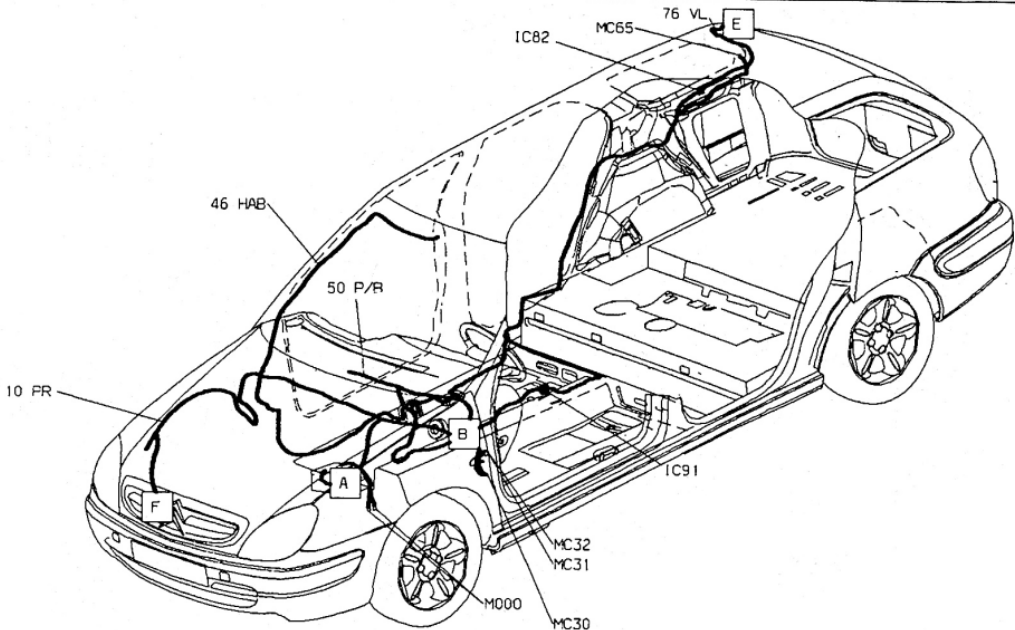

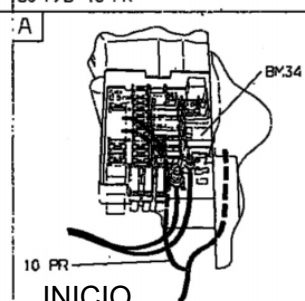
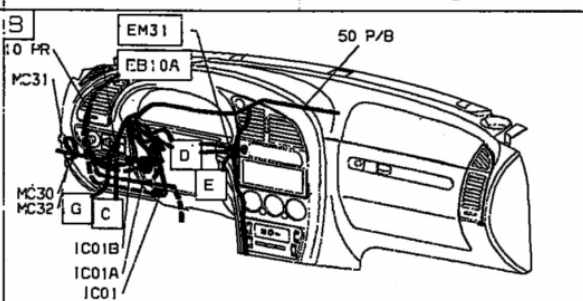
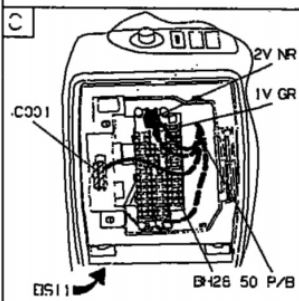
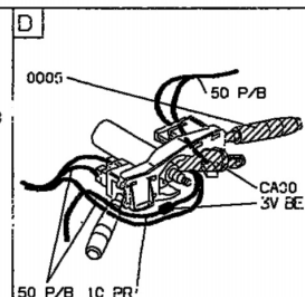
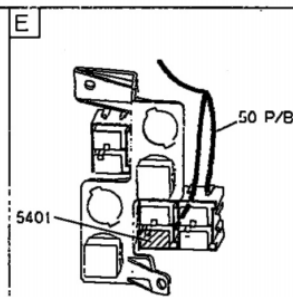
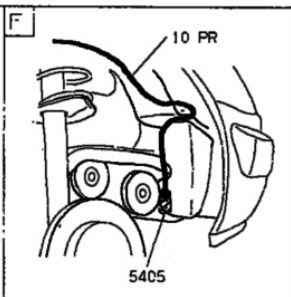
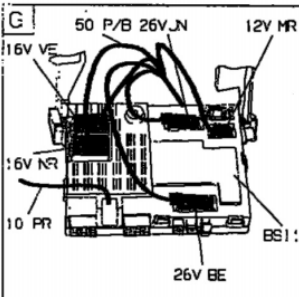
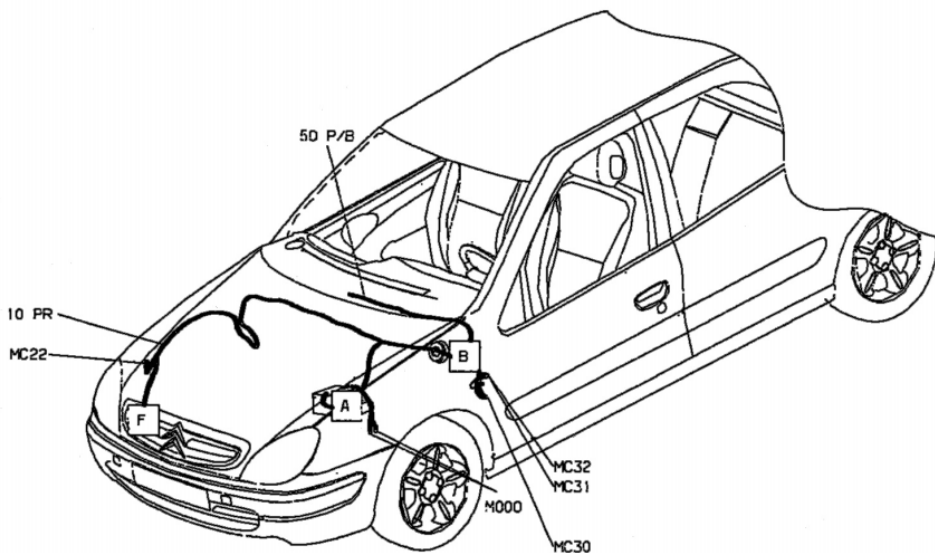

Luneta térmica e retrovisores calefactados

3 e 5 portas

Break

INICIO

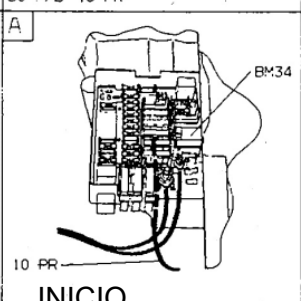
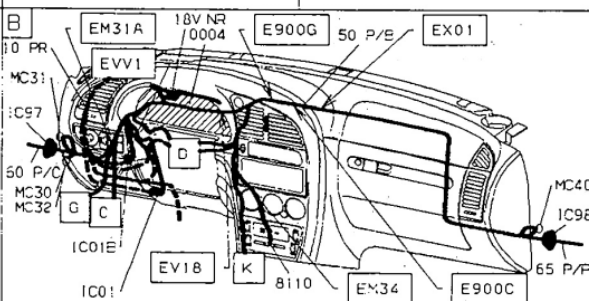
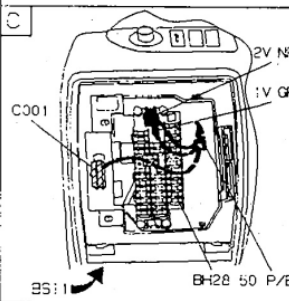
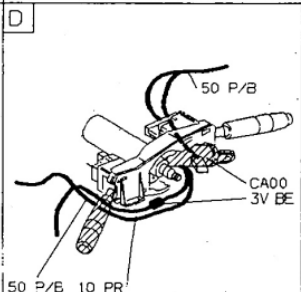
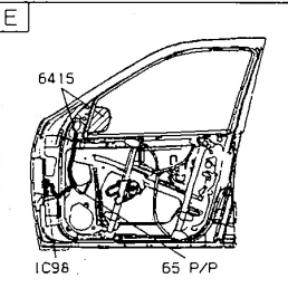
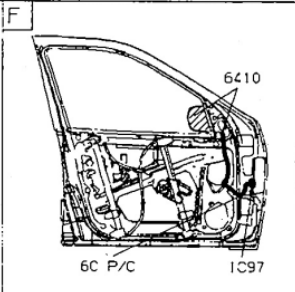
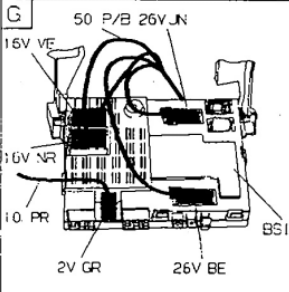
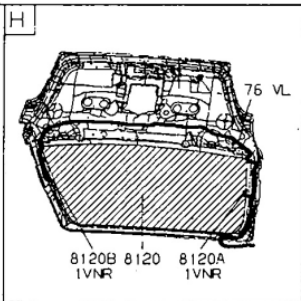
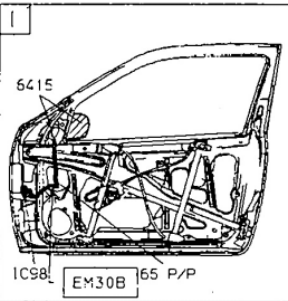
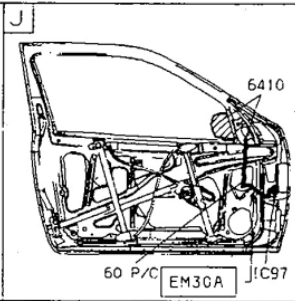
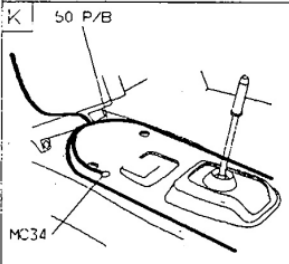
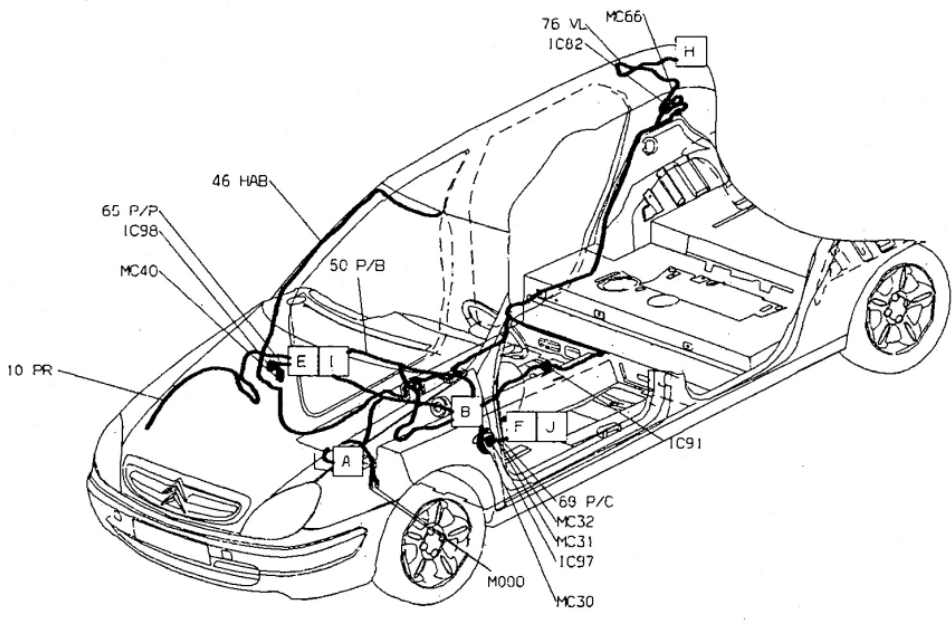

INICIO

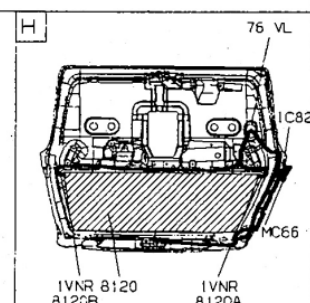
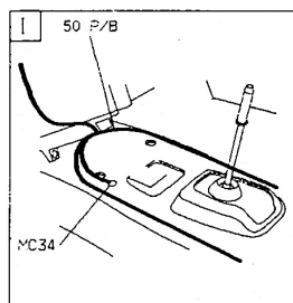
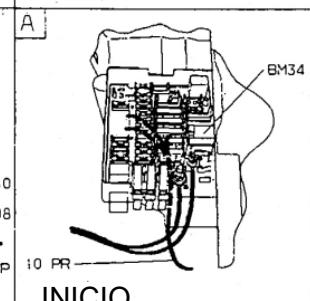
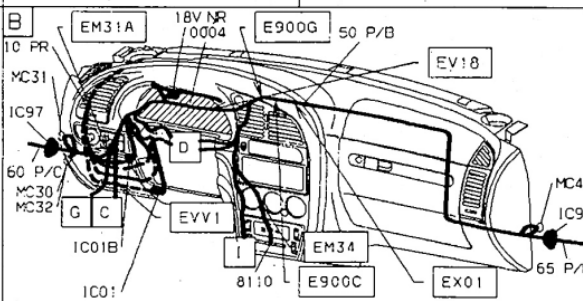
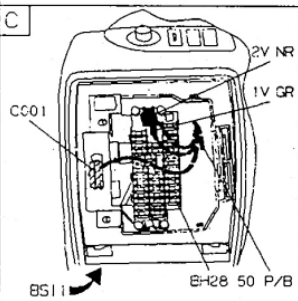
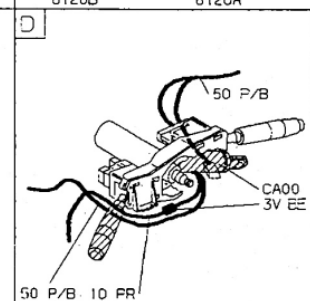
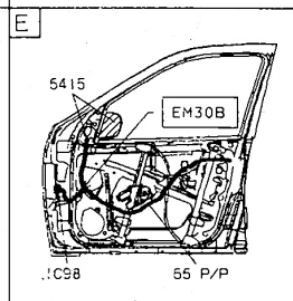
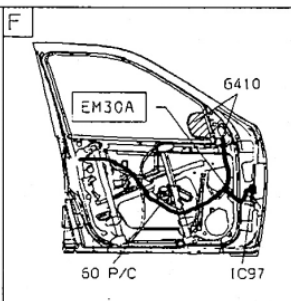
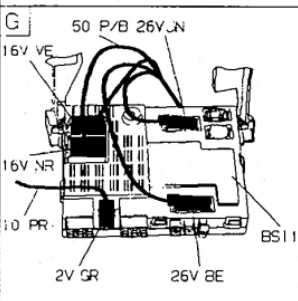
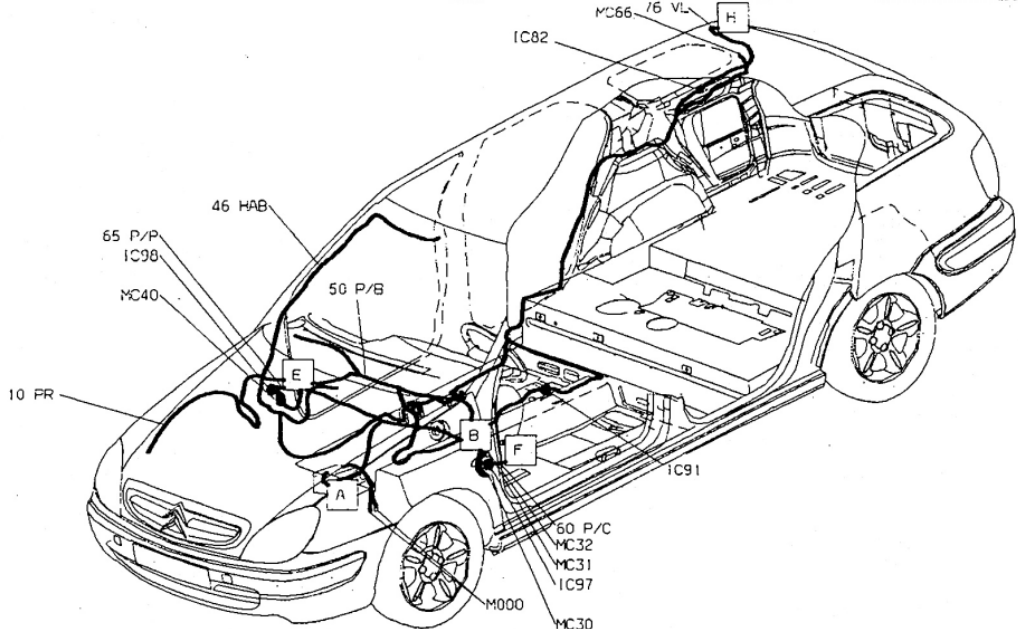

INICIO

Evaluas



INICIO

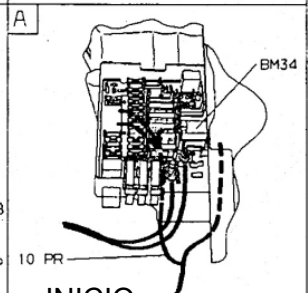
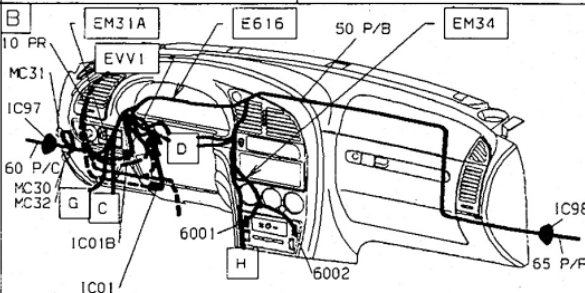
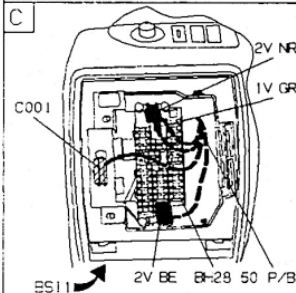
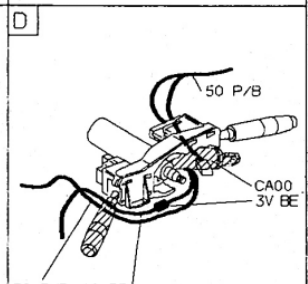
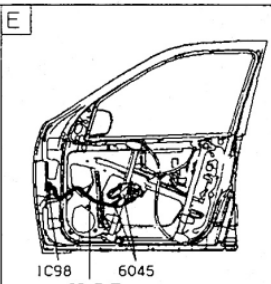
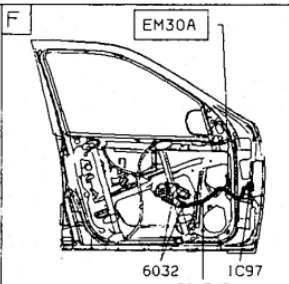
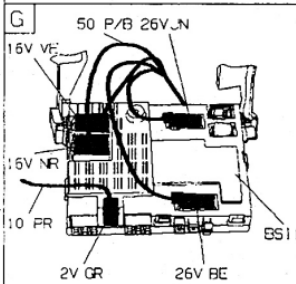
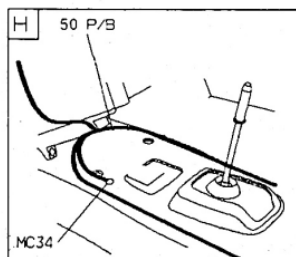
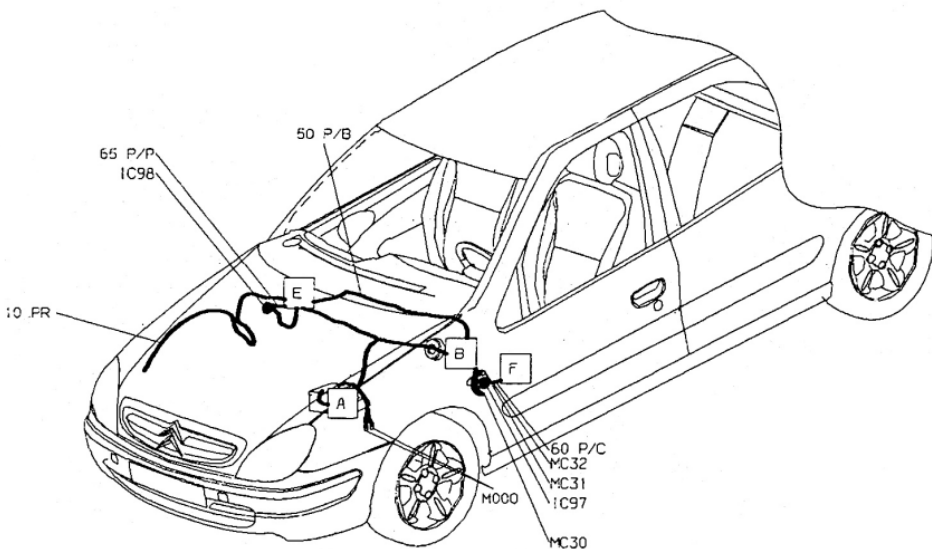

INICIO

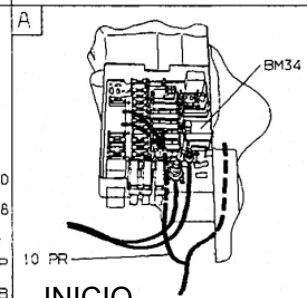
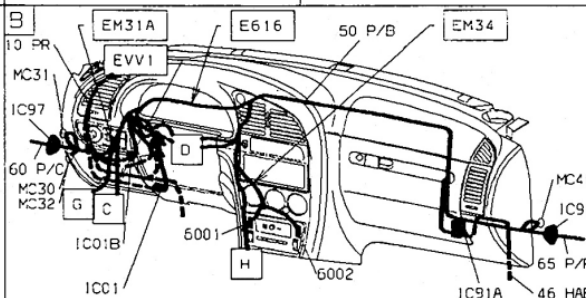
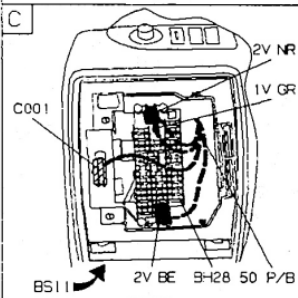
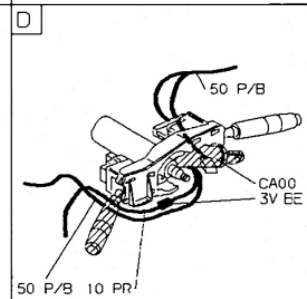
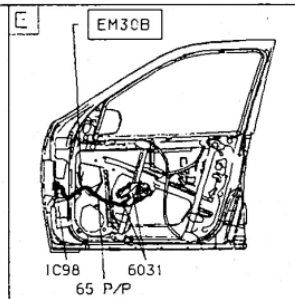
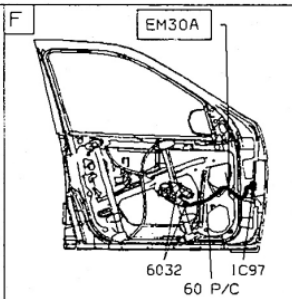
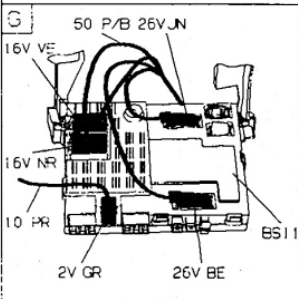
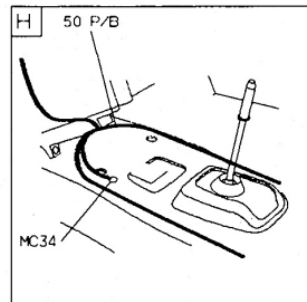
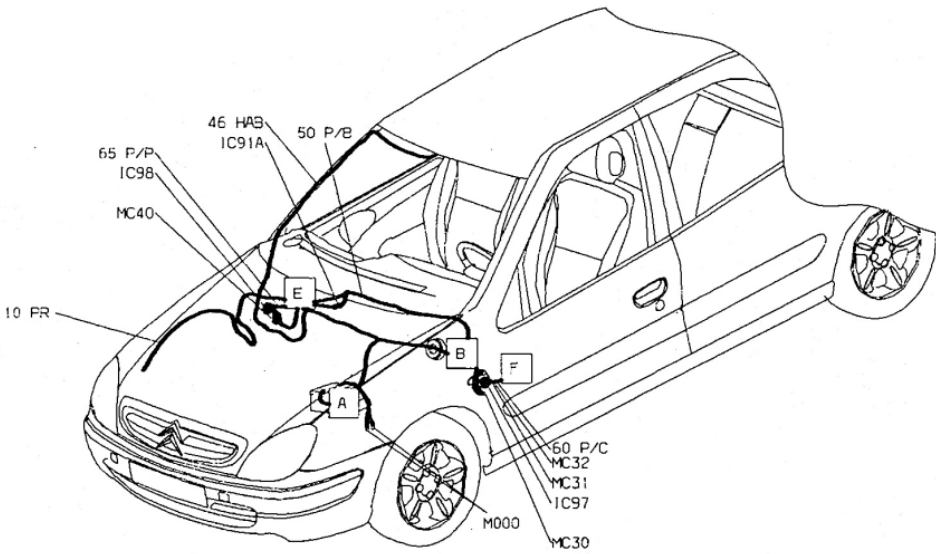

INICIO

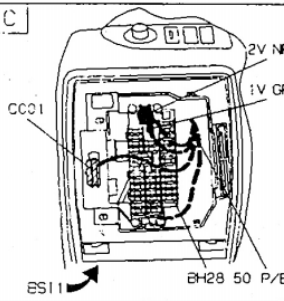
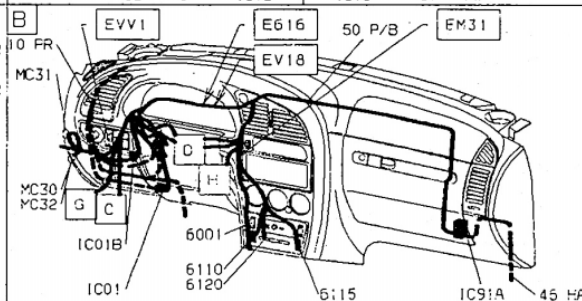
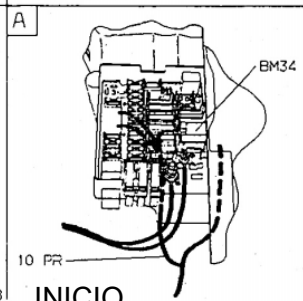
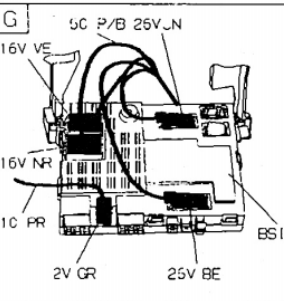
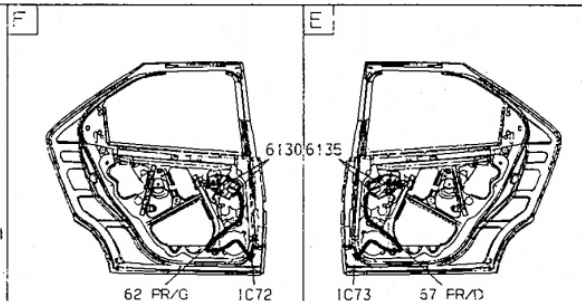
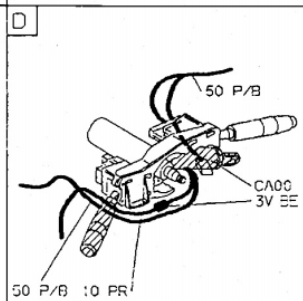
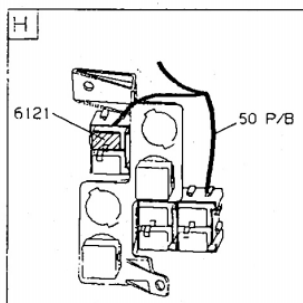
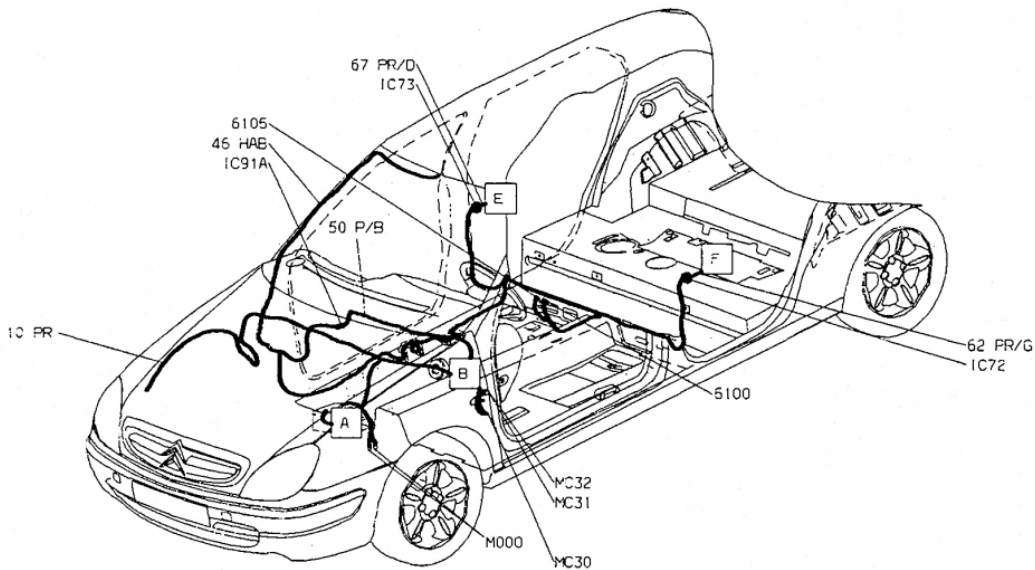

INICIO

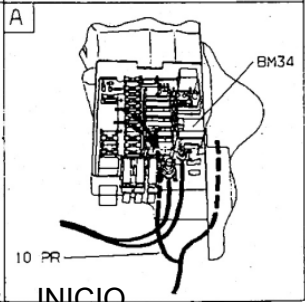
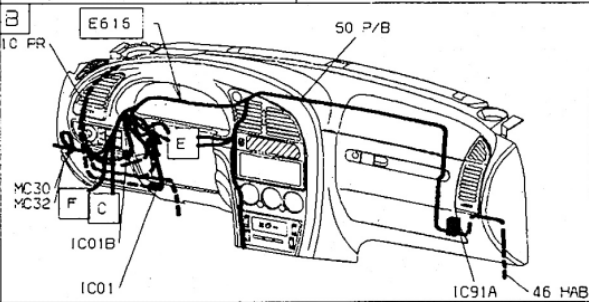
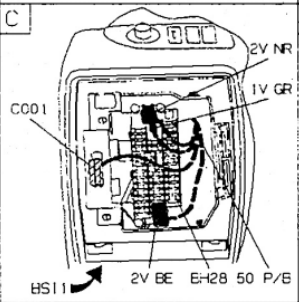
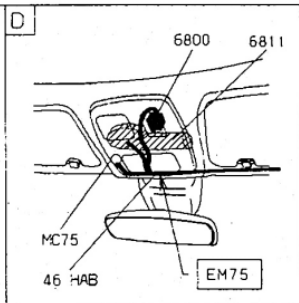
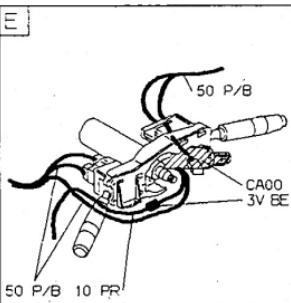
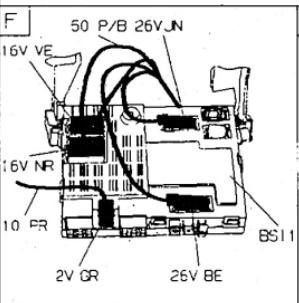
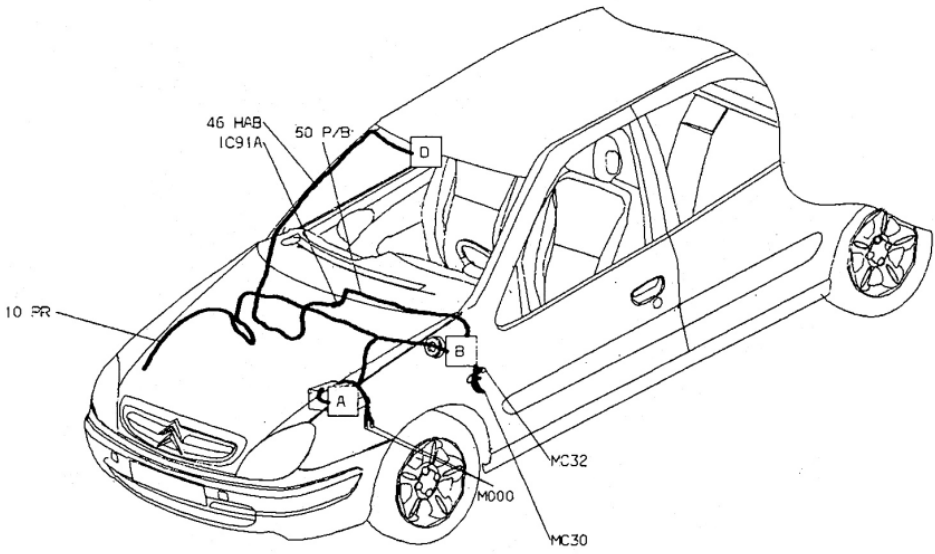

INICIO

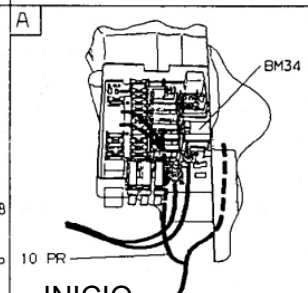
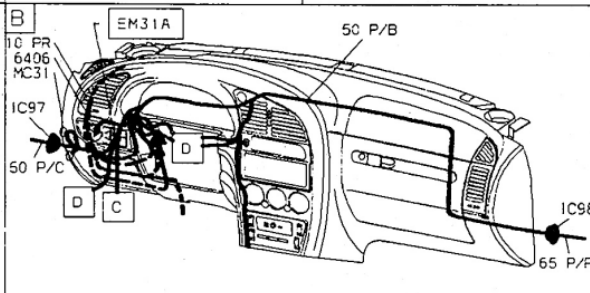
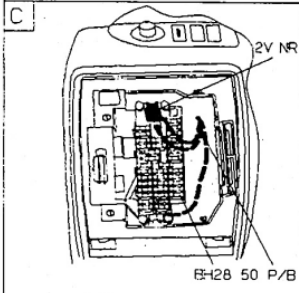
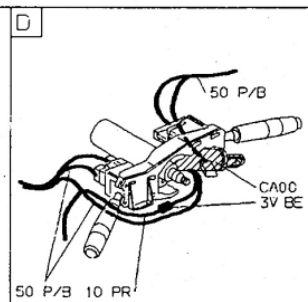
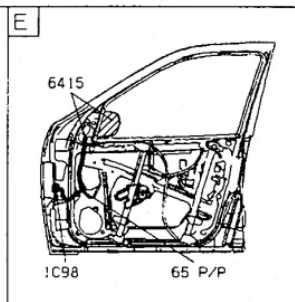
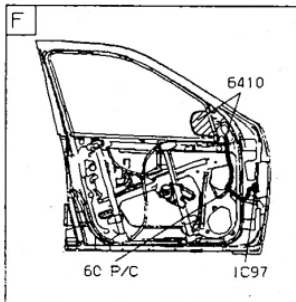
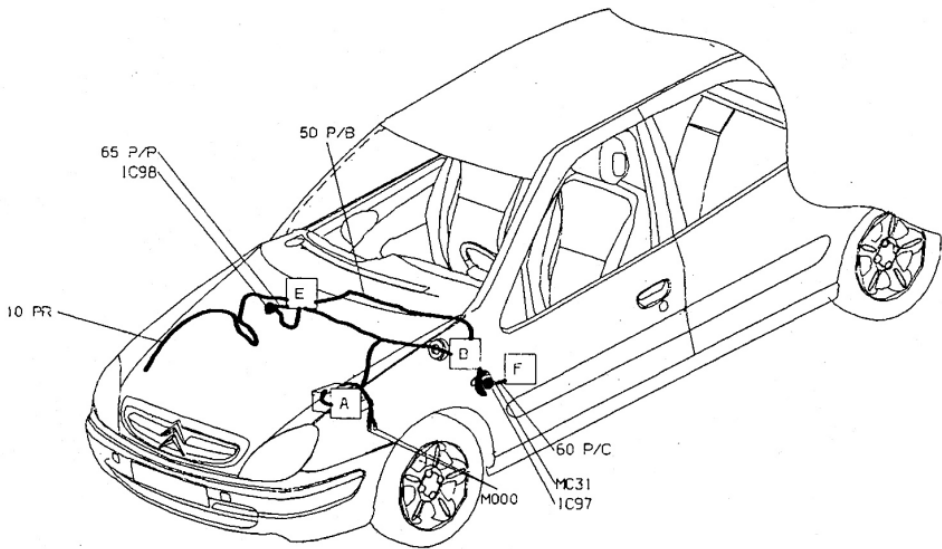

INICIO

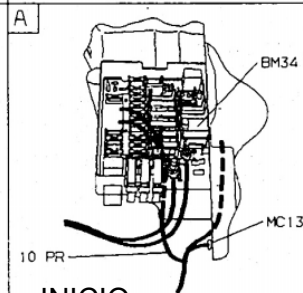
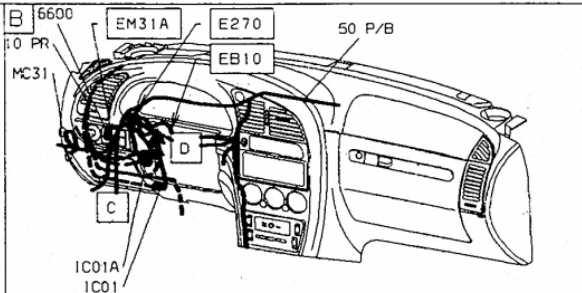
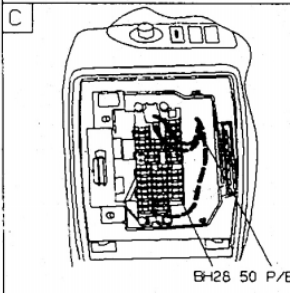
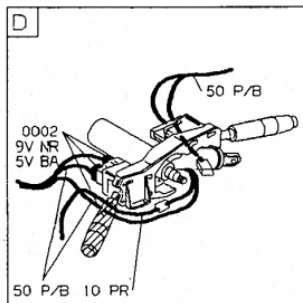
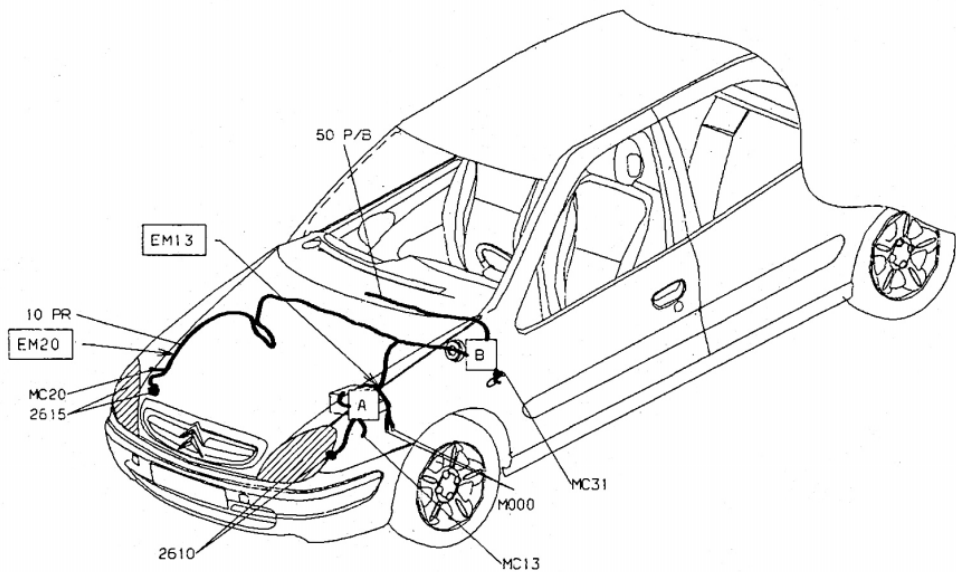

INICIO

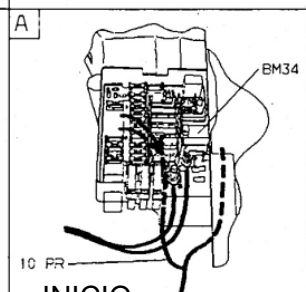
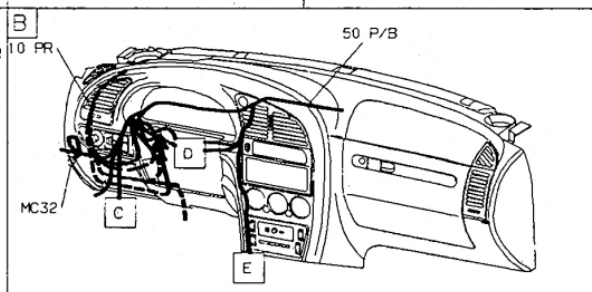
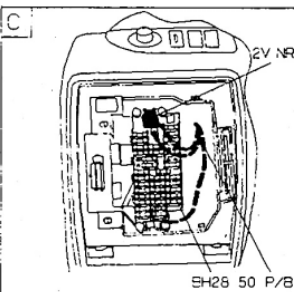
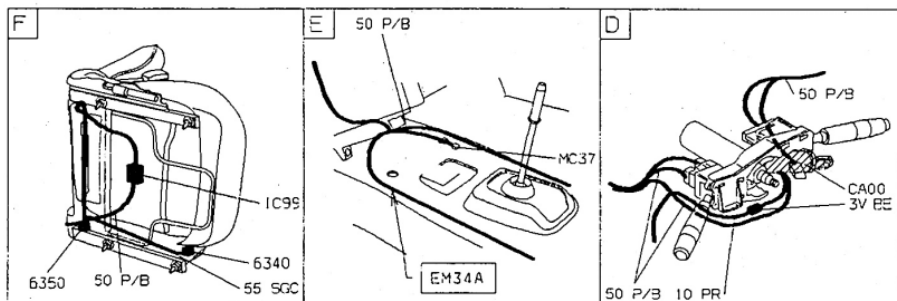
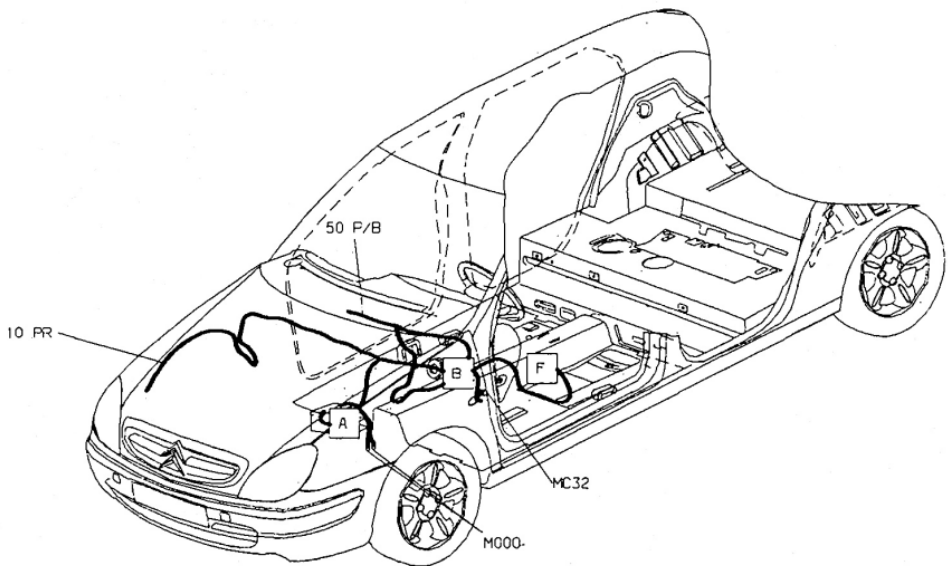

INICIO

Climatización

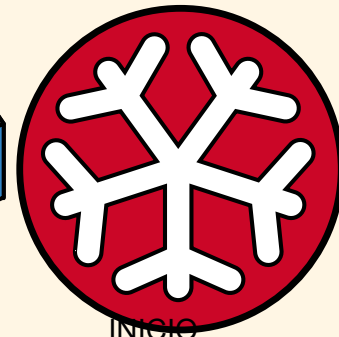
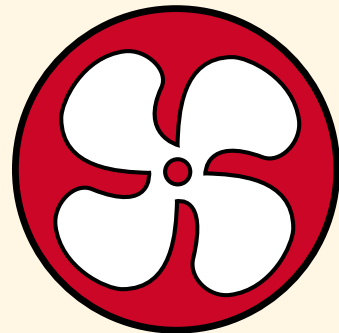
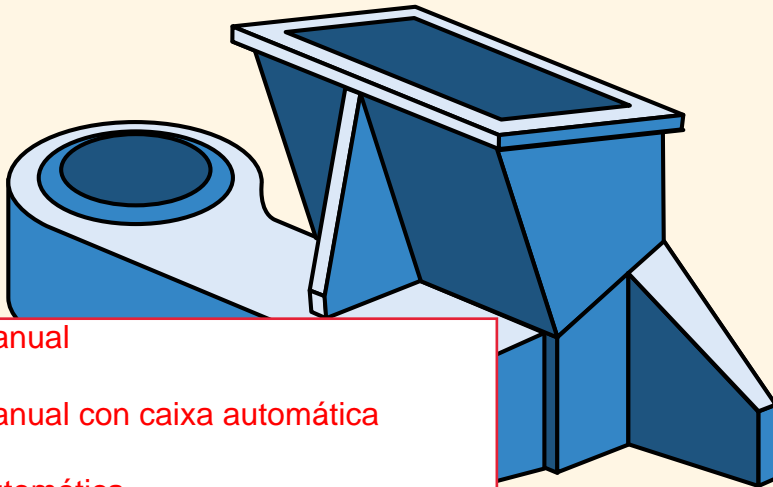

INICIO

Manual

Manual con caixa automática

Automática

Automática con caixa automática

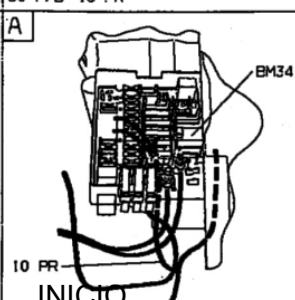
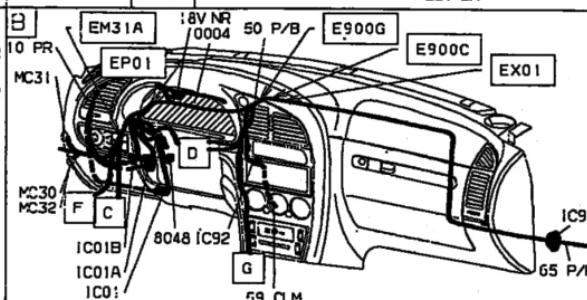
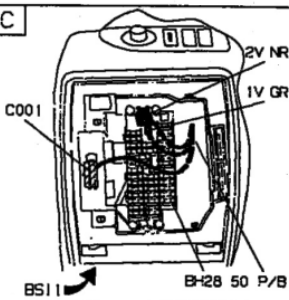
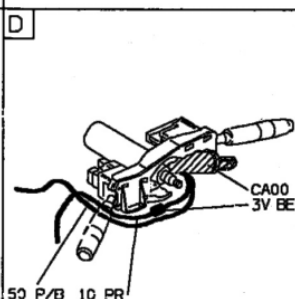
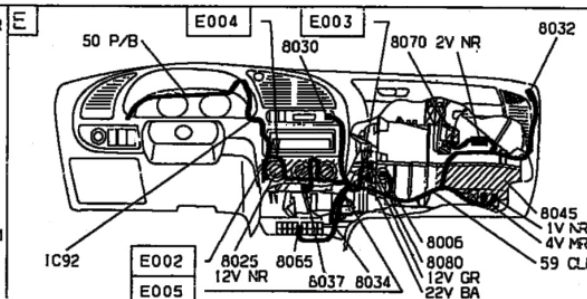
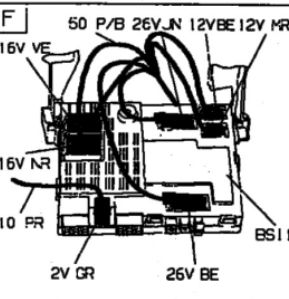
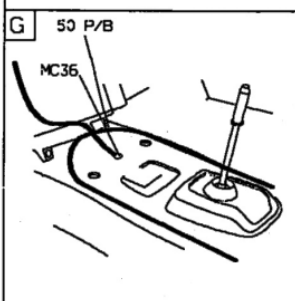
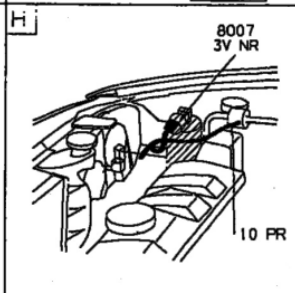
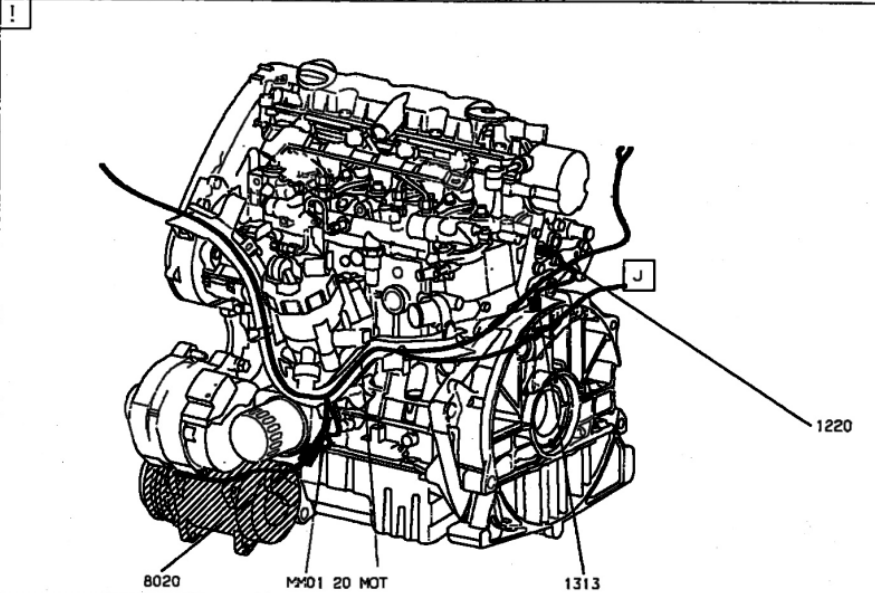
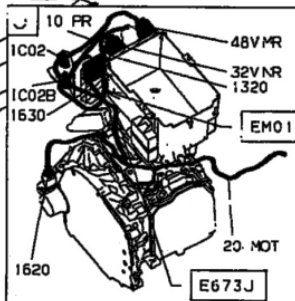
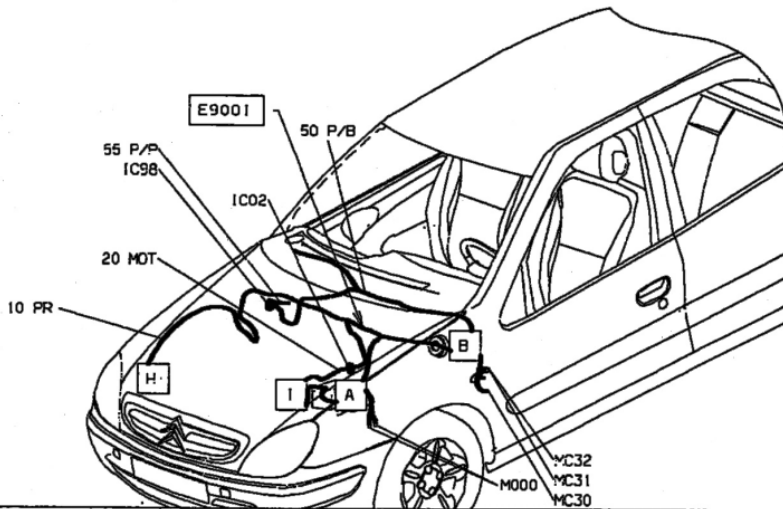

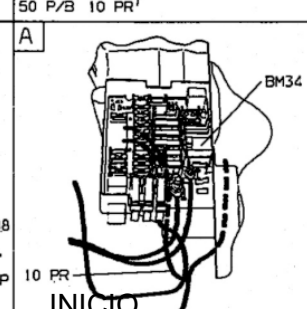
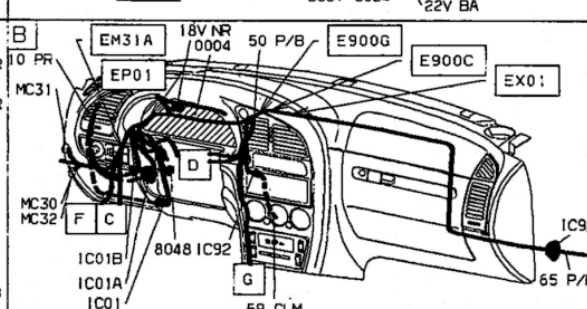
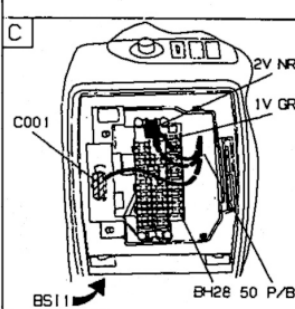
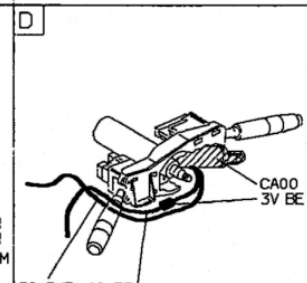
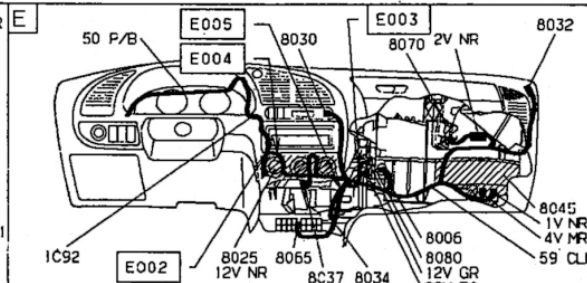
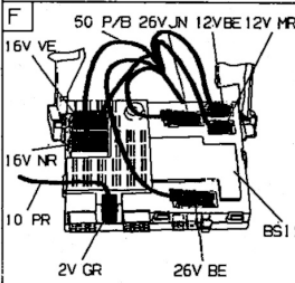
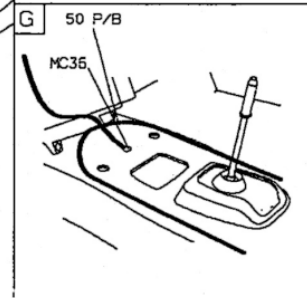
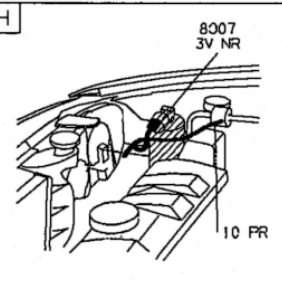
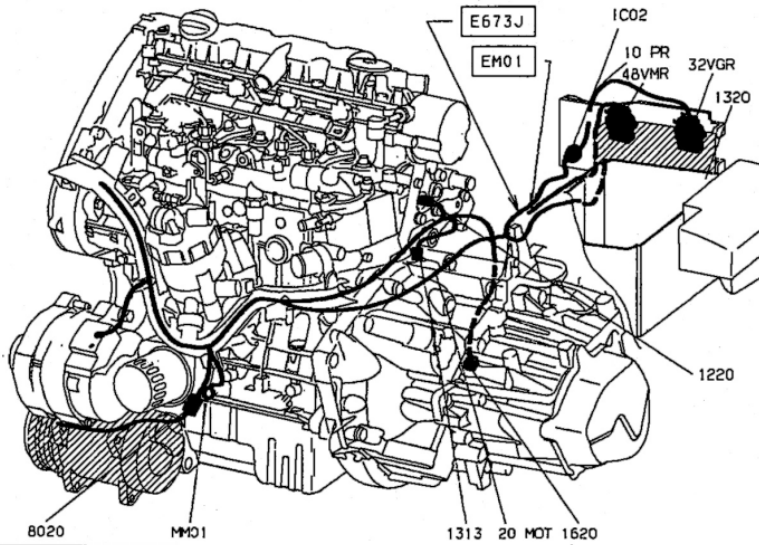
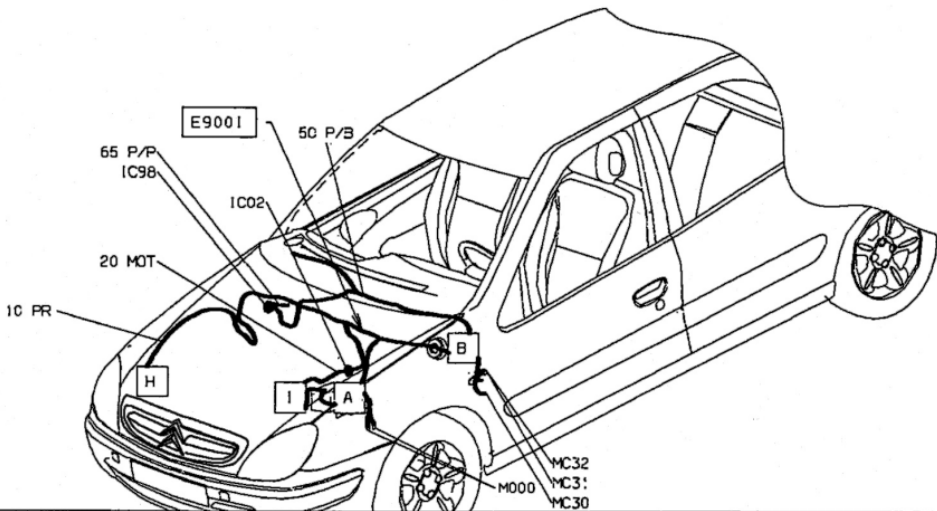

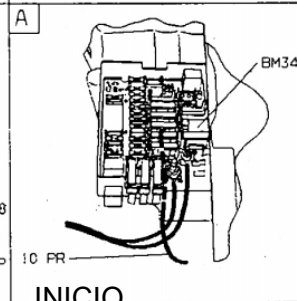
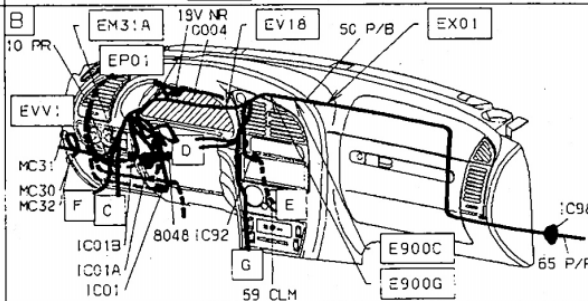
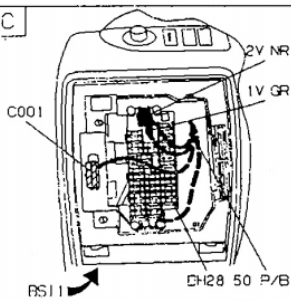
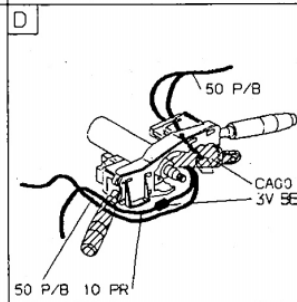
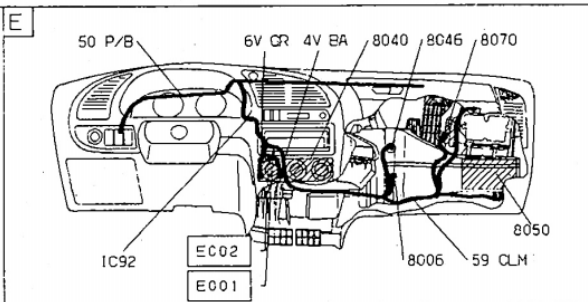
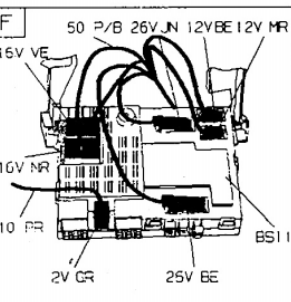
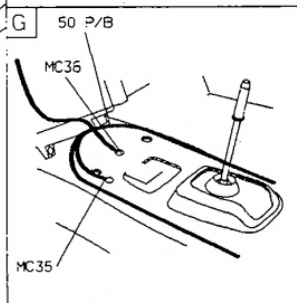
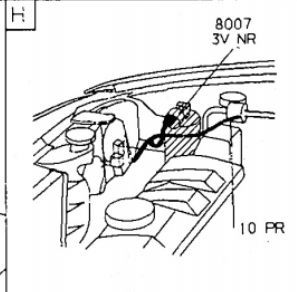
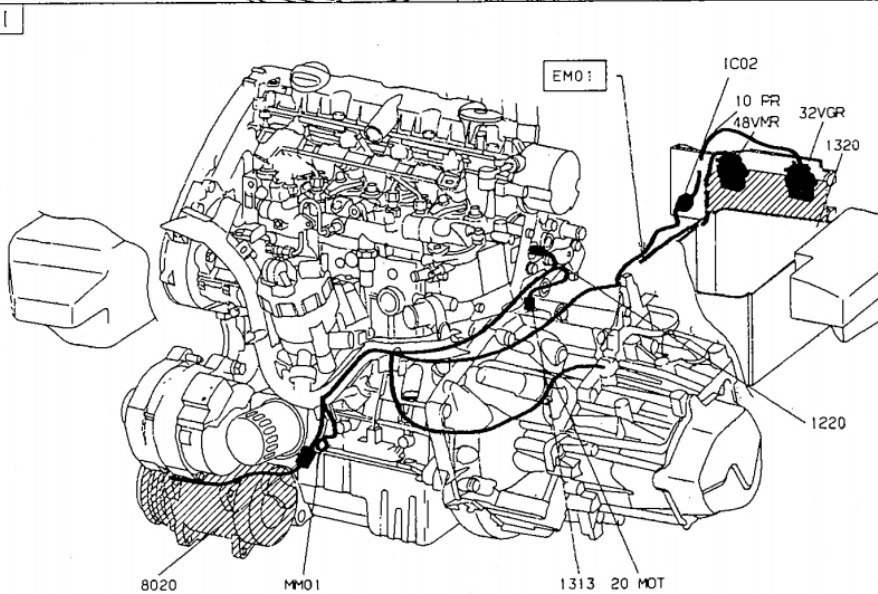
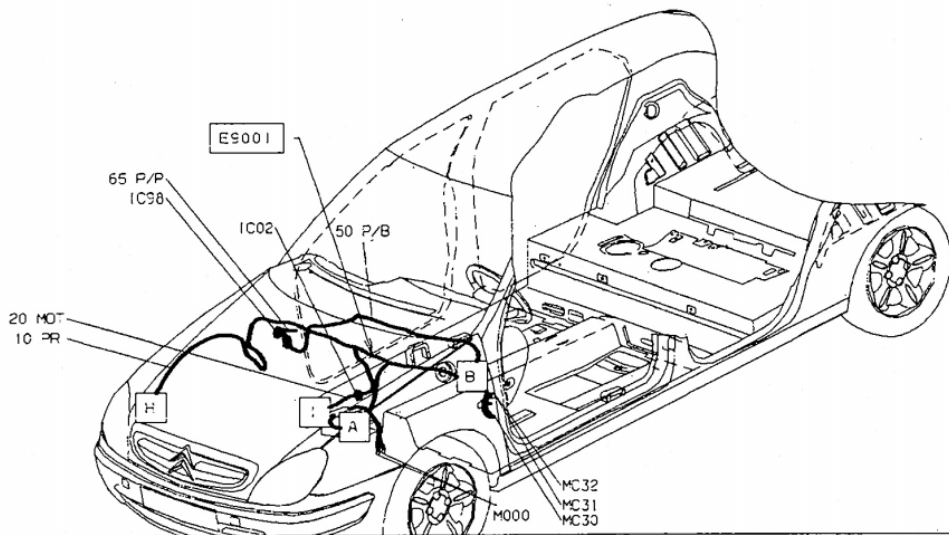

INICIO

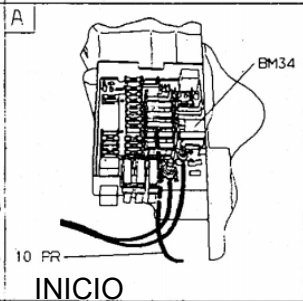
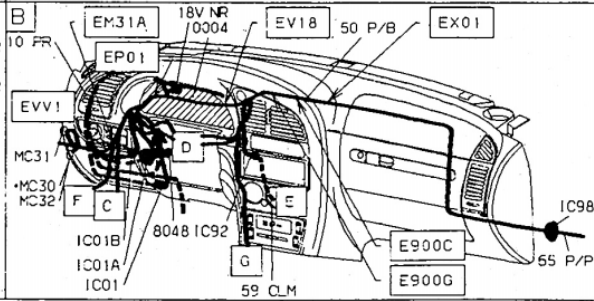
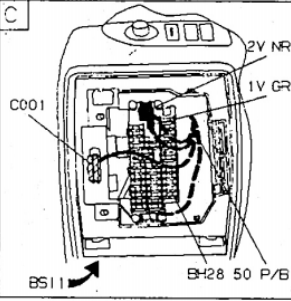
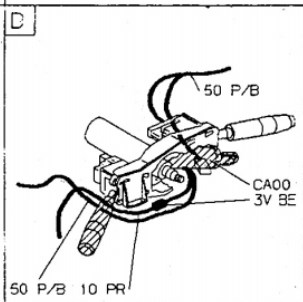
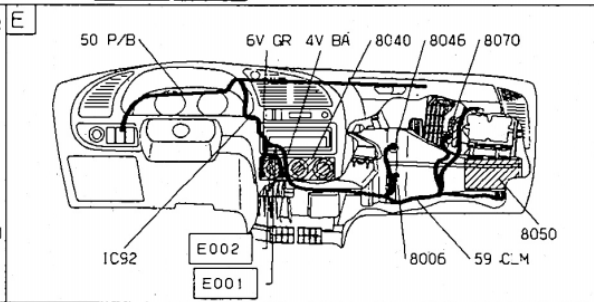
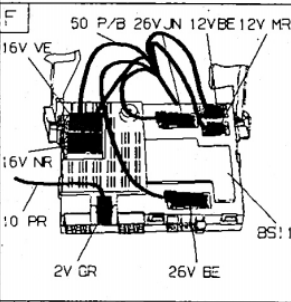
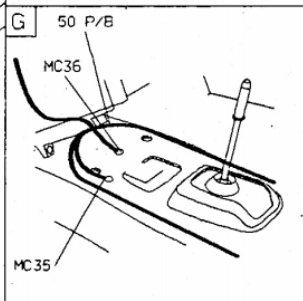
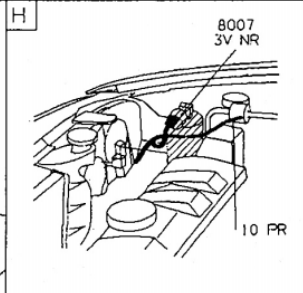
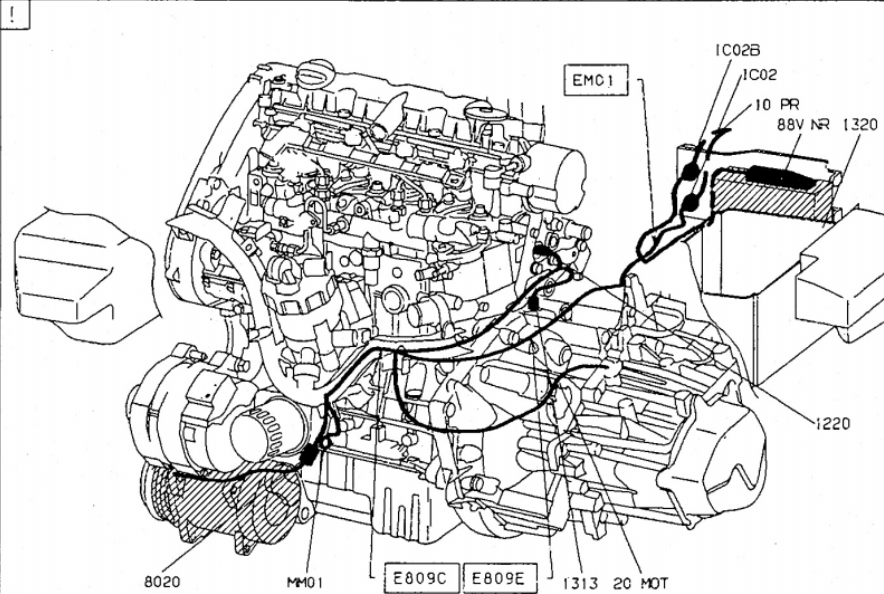
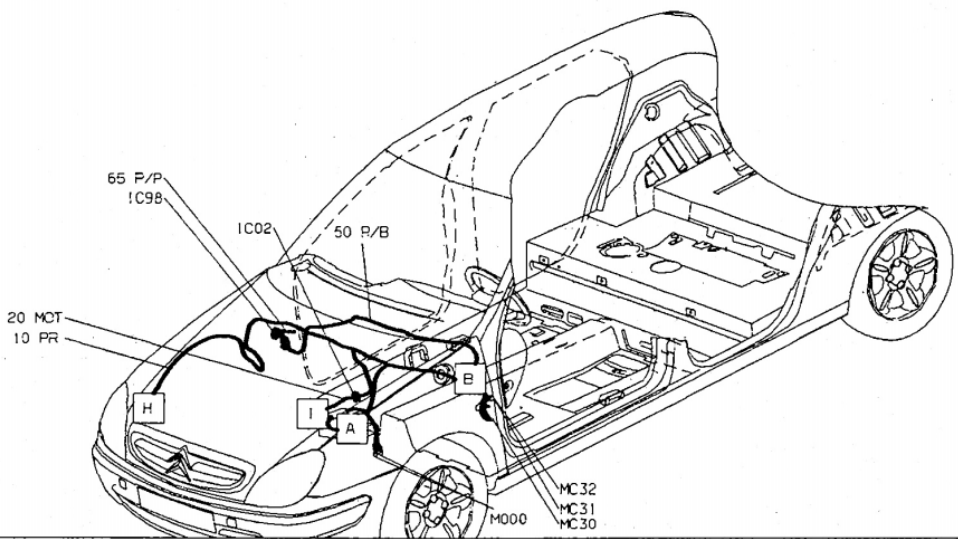

INICIO

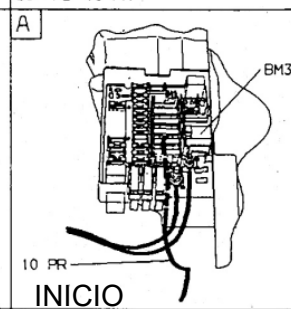
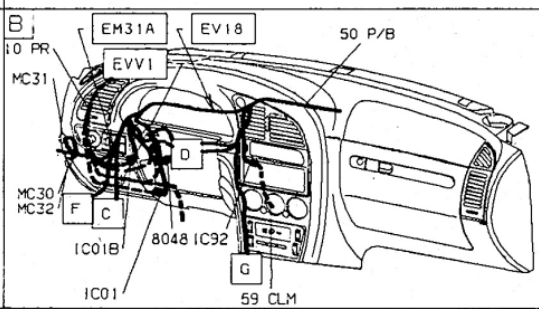
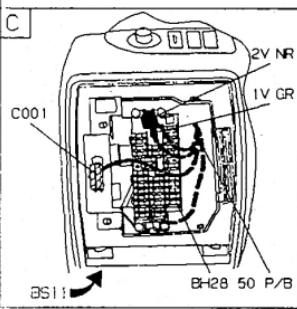
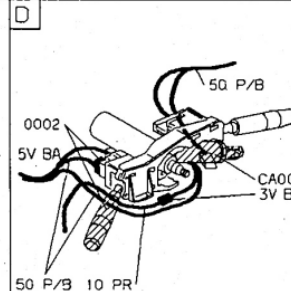
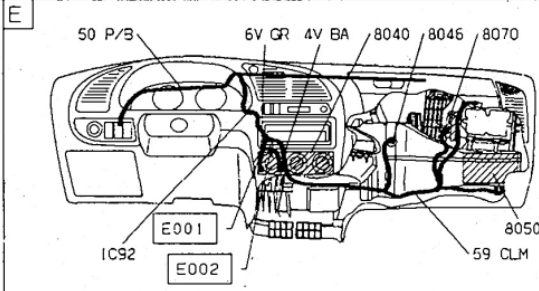
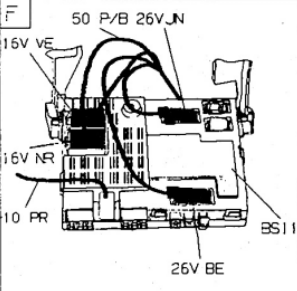
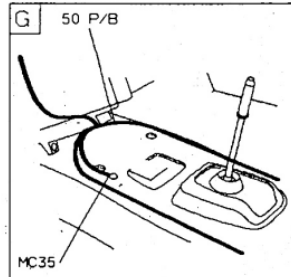
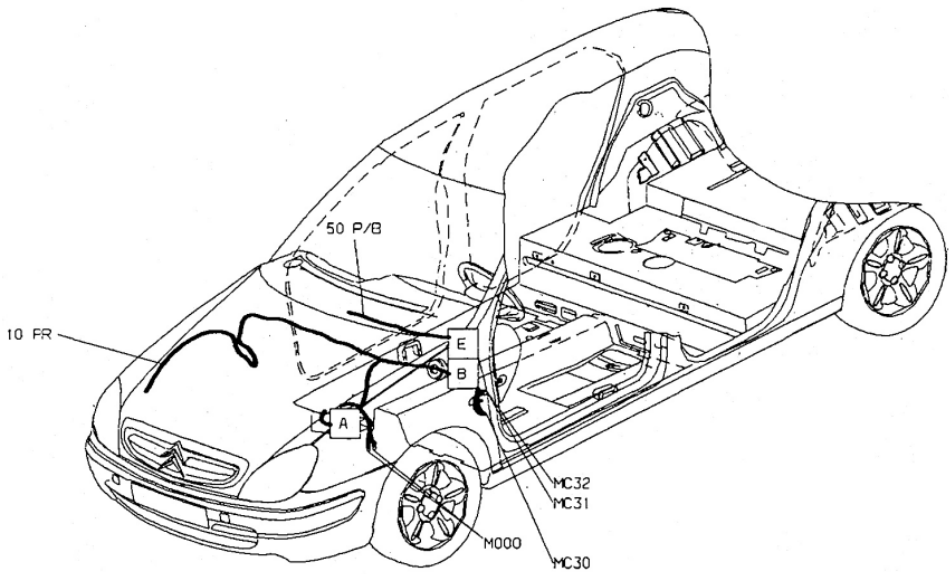

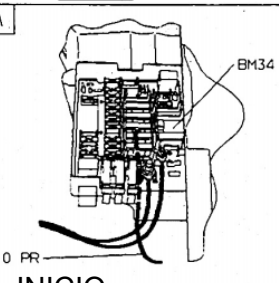
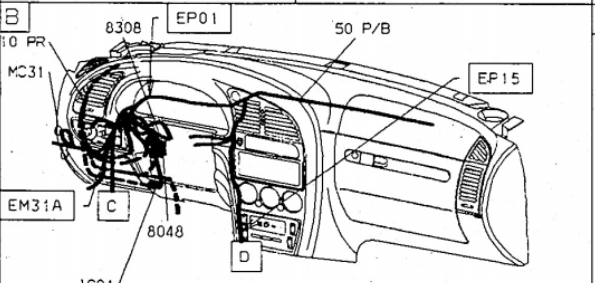
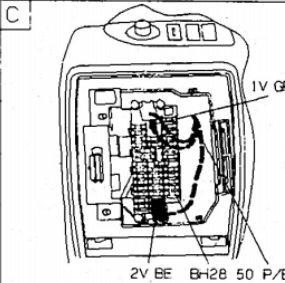
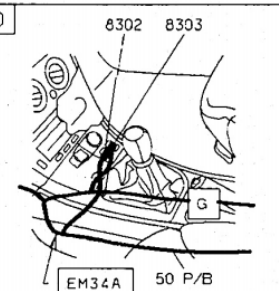
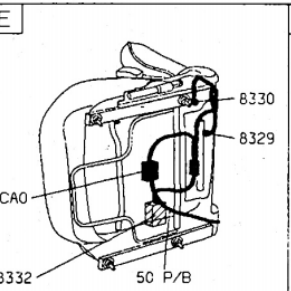
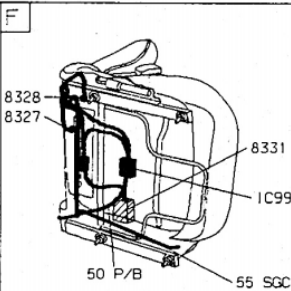
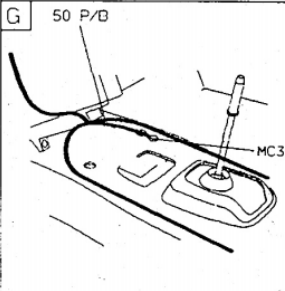
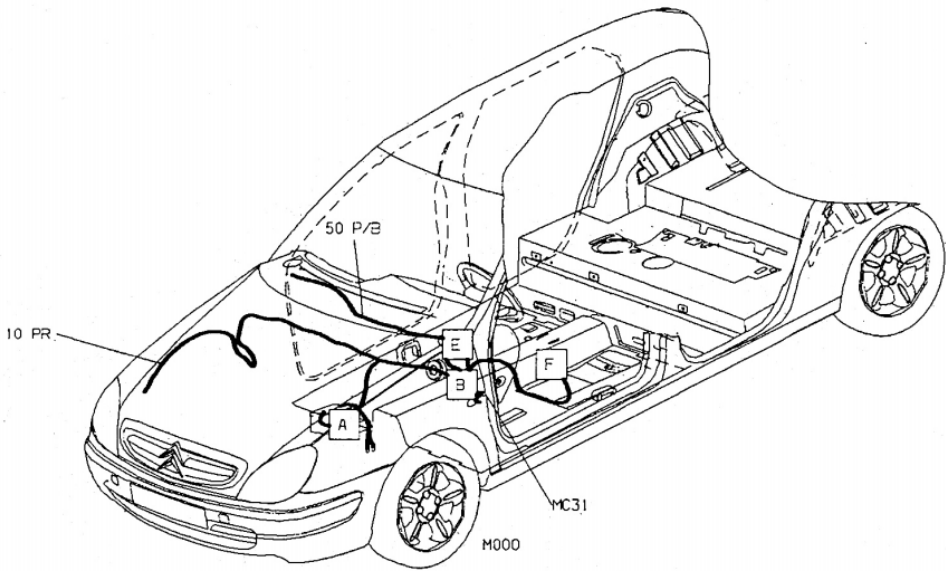

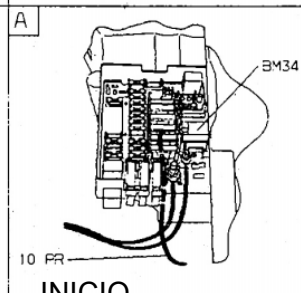
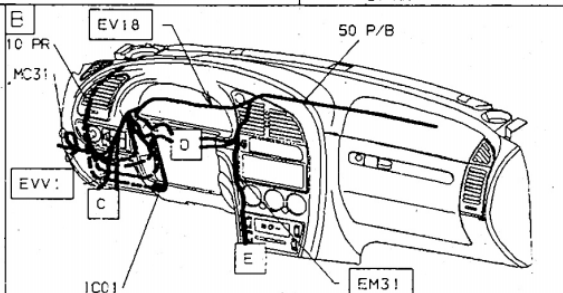
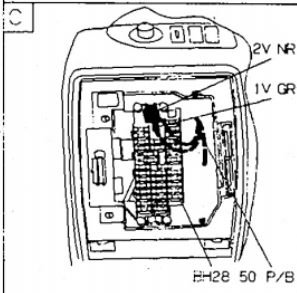
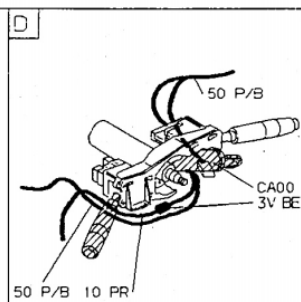
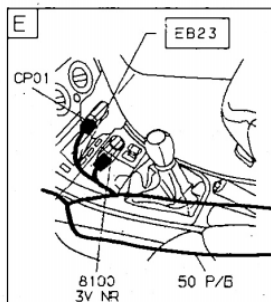
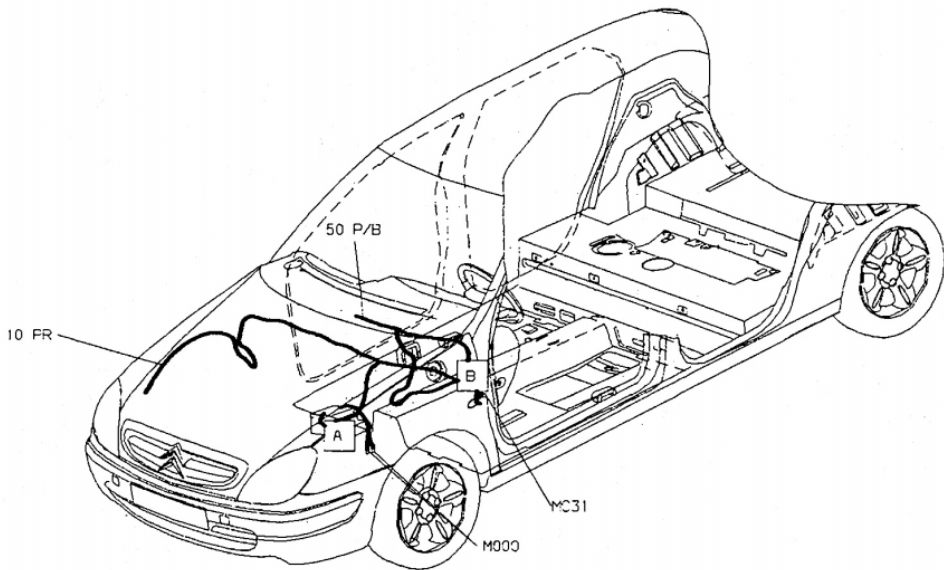

AUTORADIO

3 portas

5 portas e Break

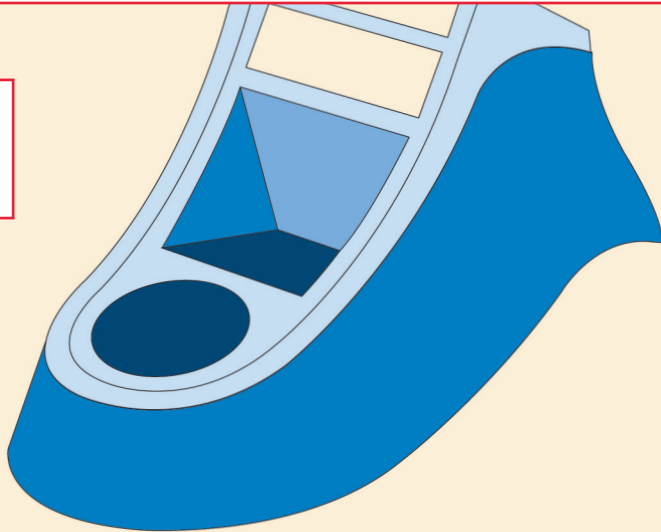

INICIO

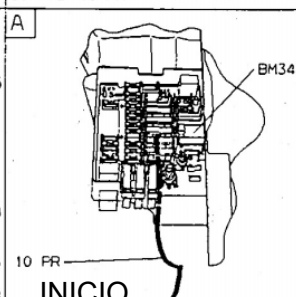
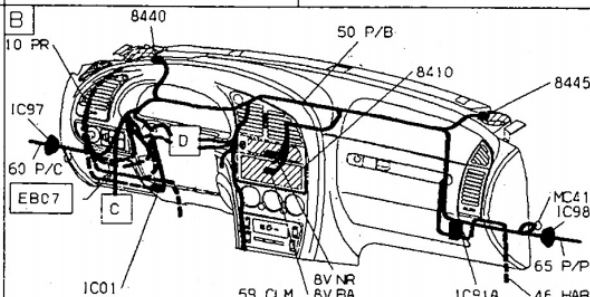
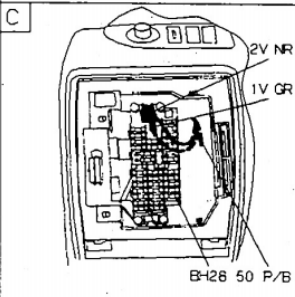
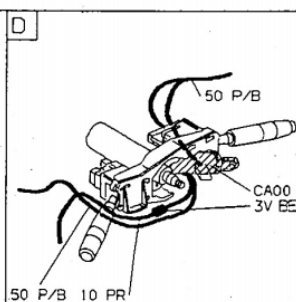
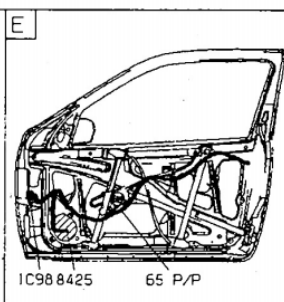
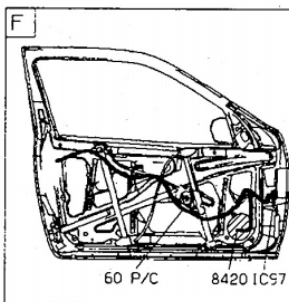
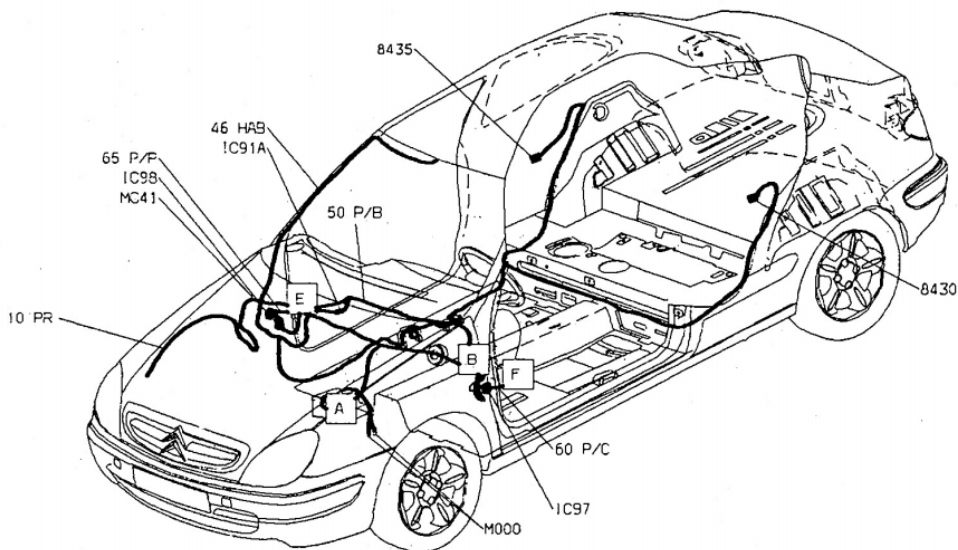

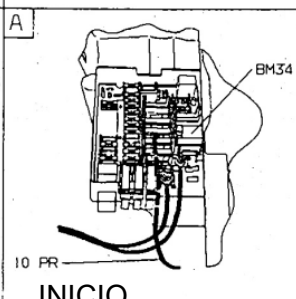
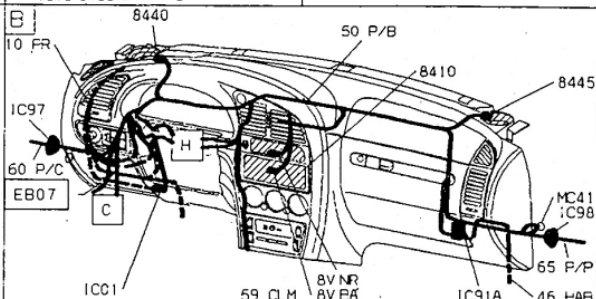
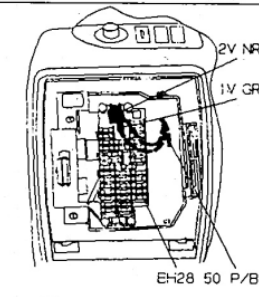
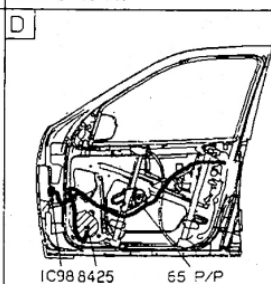
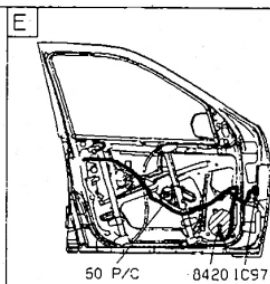
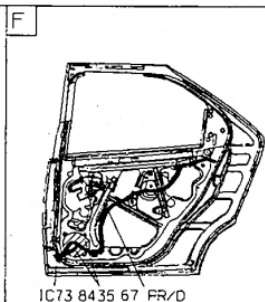
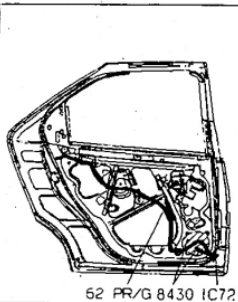
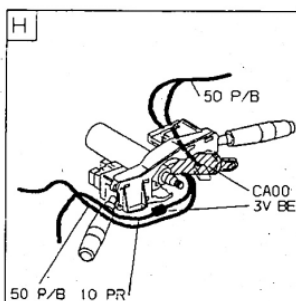
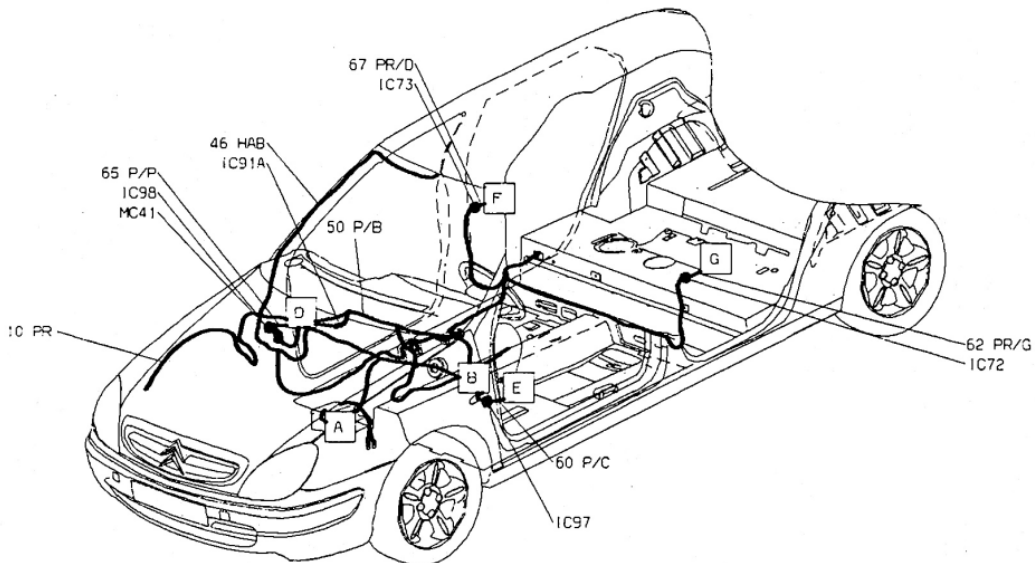

Cableados

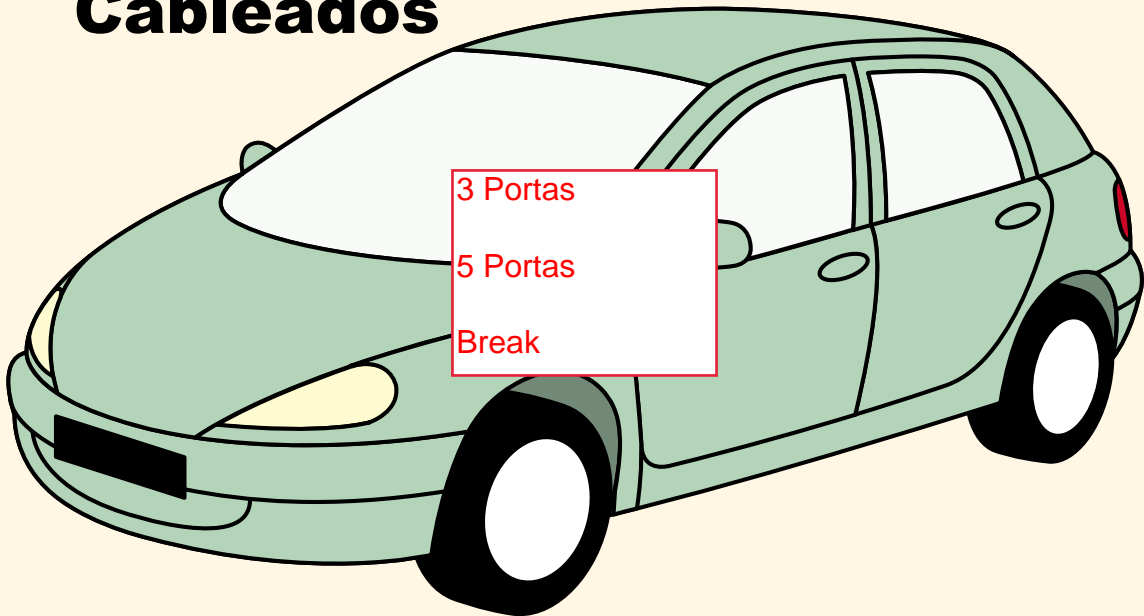

3 Portas

5 Portas

Break

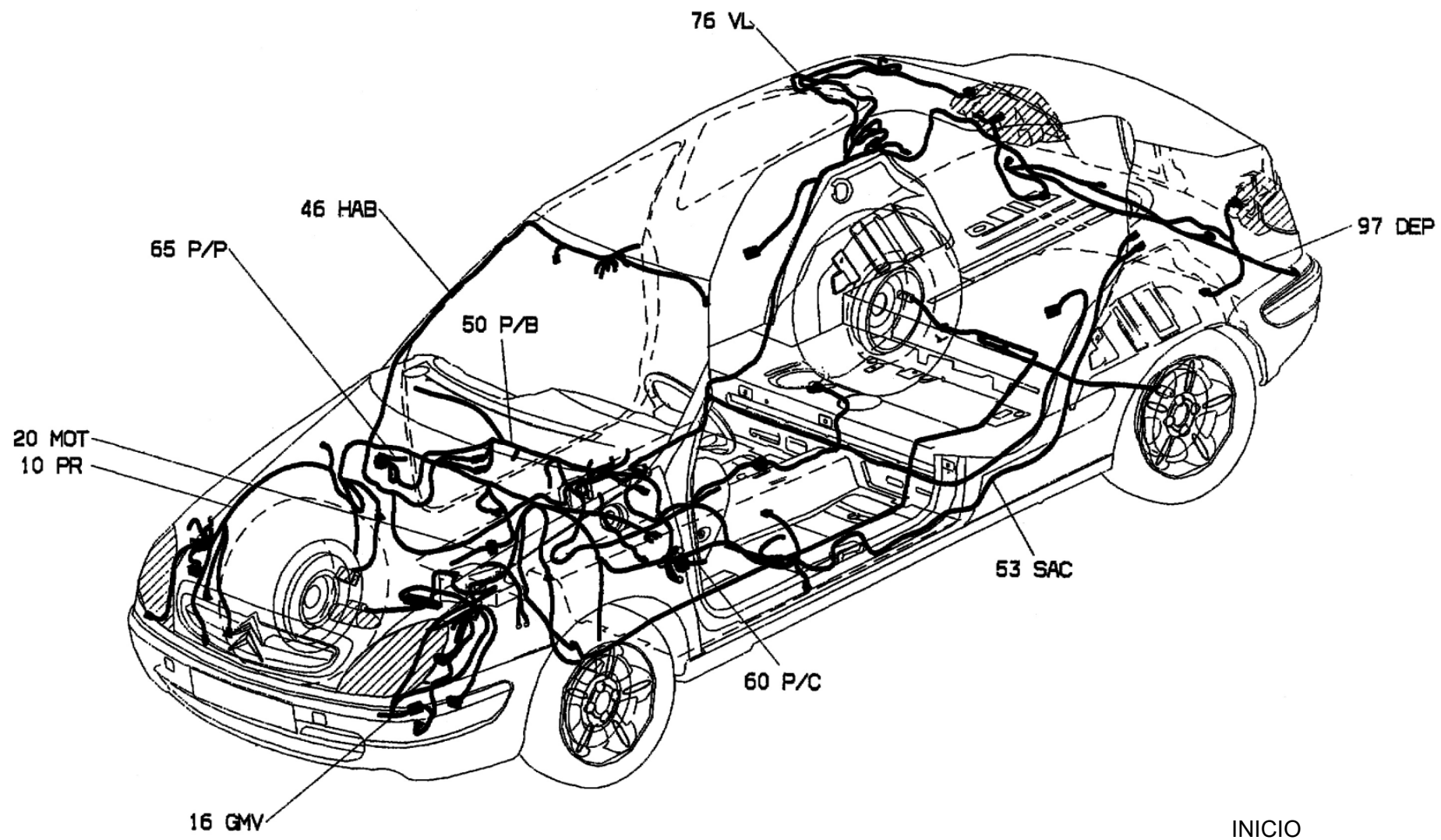

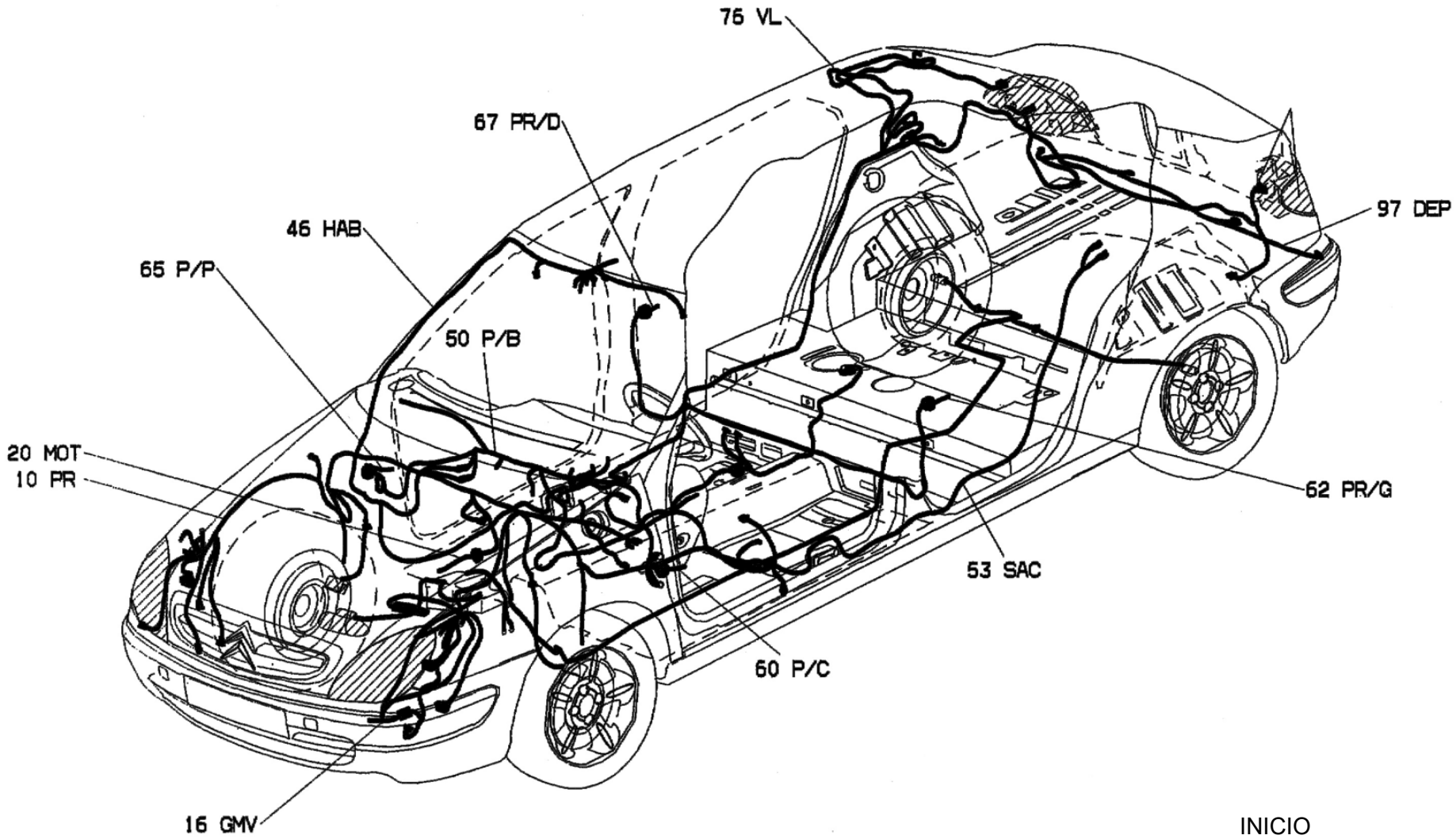

INICIO

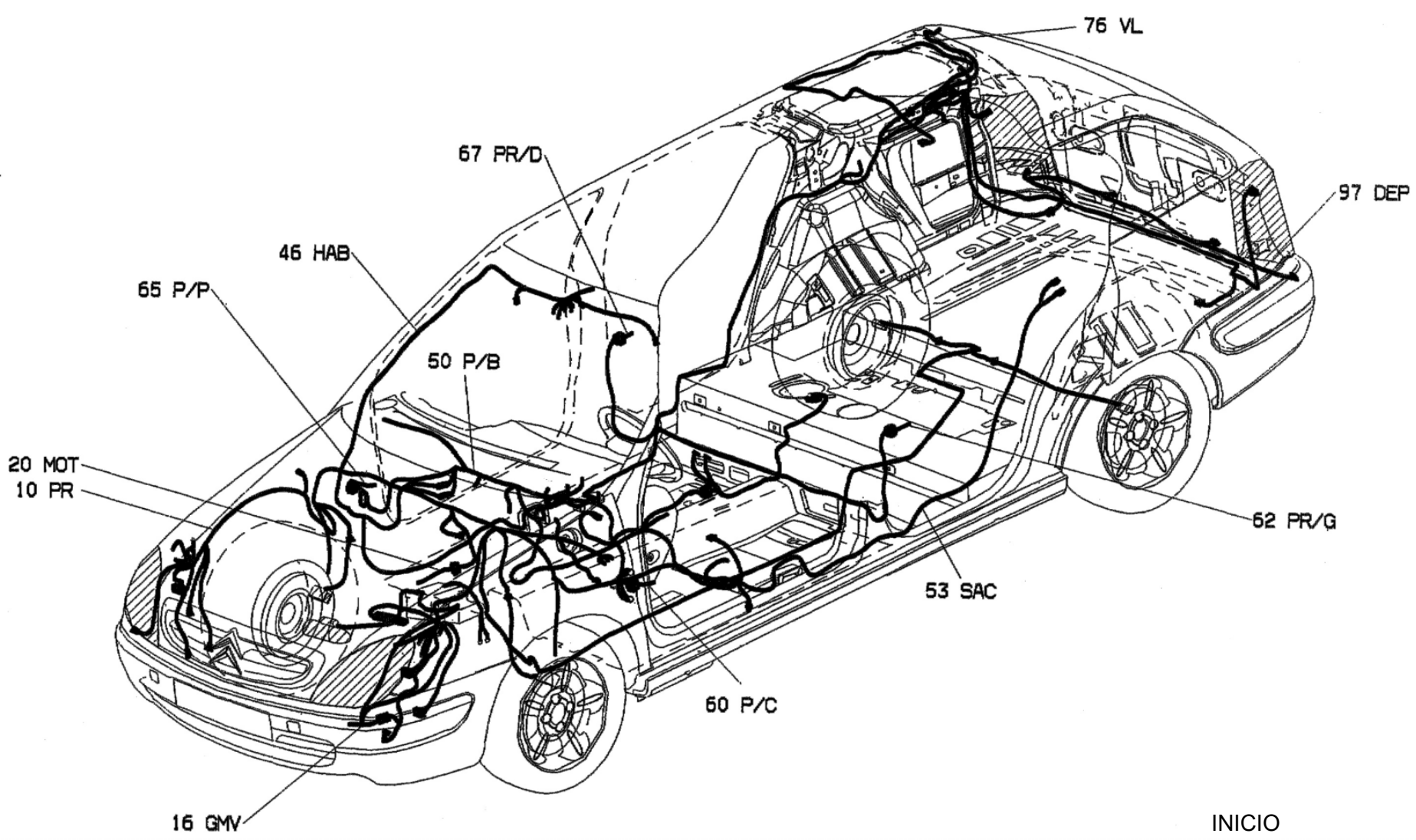

INICIO

Interconexións

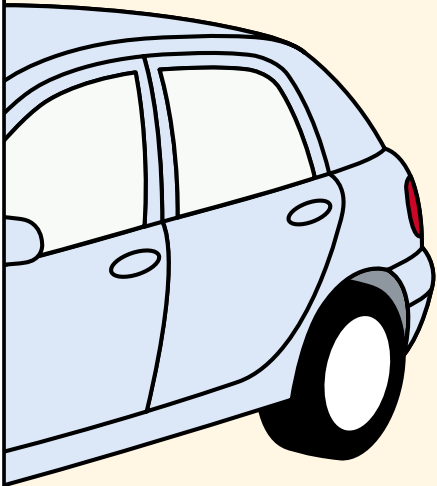

3 Portas

5 Portas

Break

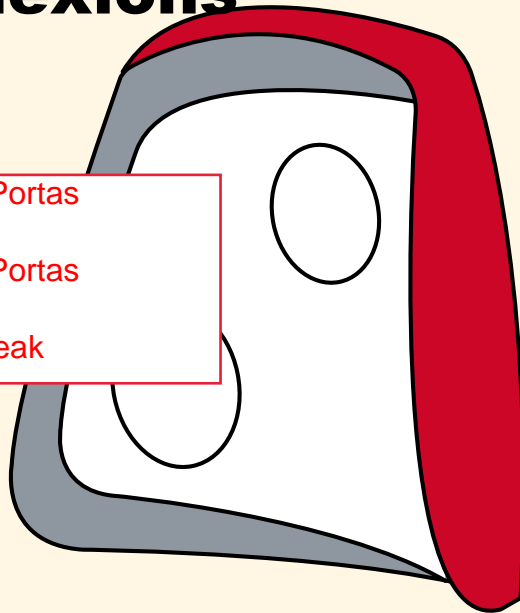

INICIO

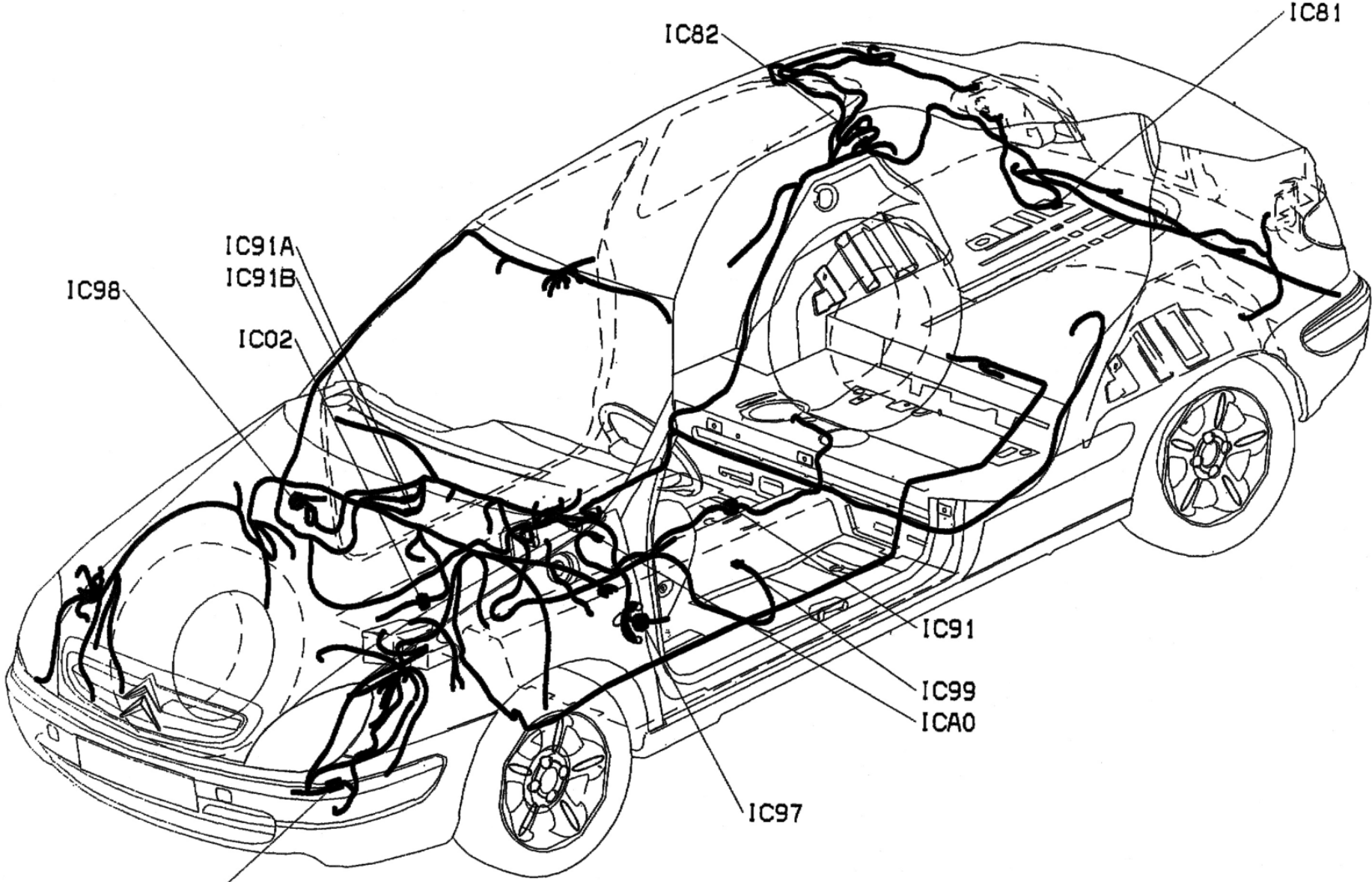

IC82

IC81

IC91A

IC91B

IC98

IC02

IC91

IC99

ICA0

IC97

IC08

INICIO

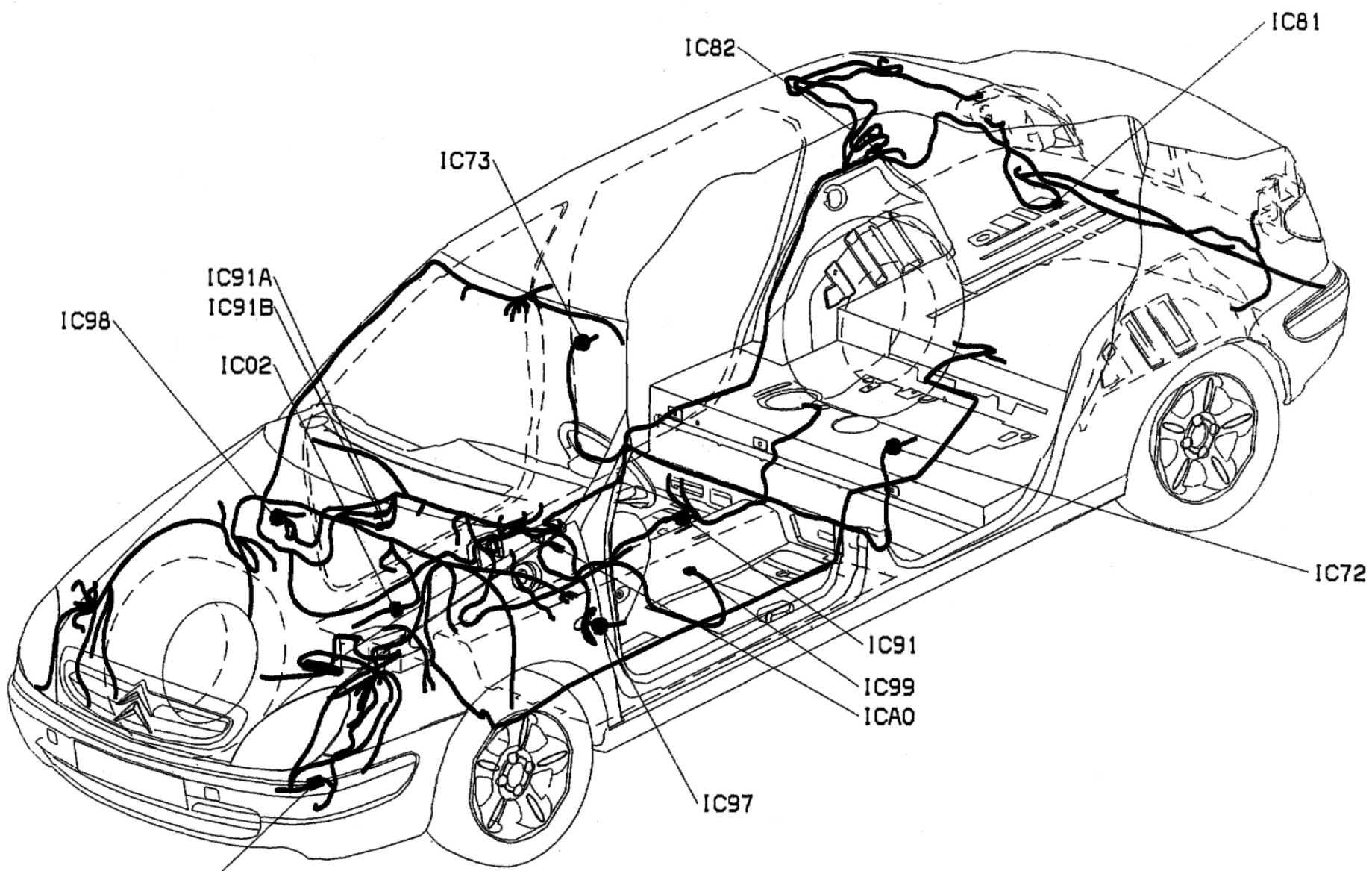

IC82

IC81

IC73

IC91A

IC91B

IC98

IC02

IC72

IC91

IC99

ICA0

IC97

IC08

INICIO

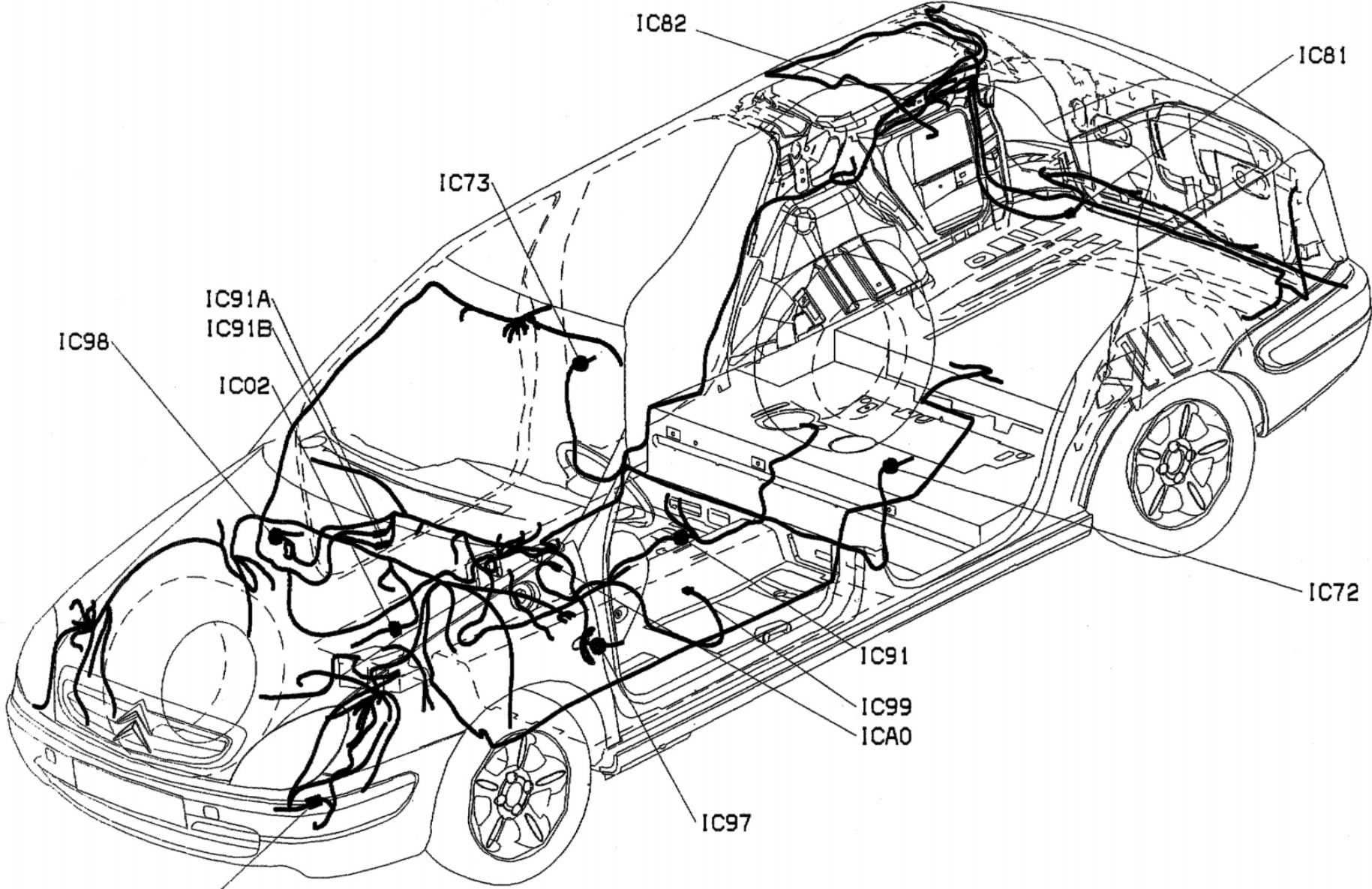

IC82

IC81

IC73

IC91A

IC91B

IC98

IC02

IC72

IC91

IC99

ICA0

IC97

IC08

INICIO

Masas

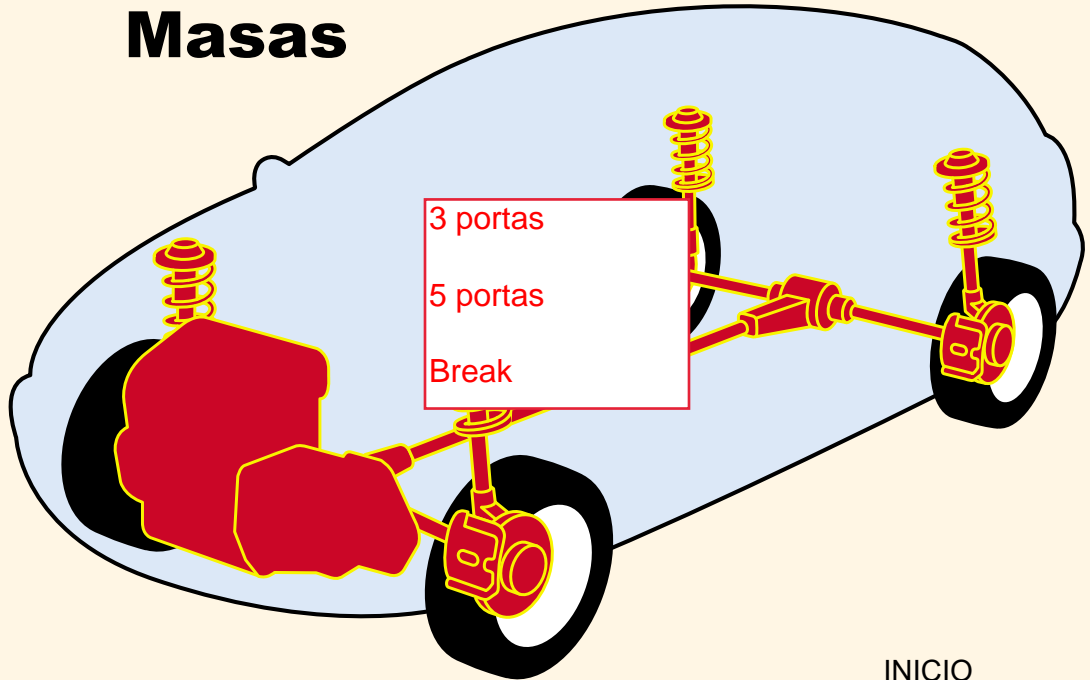

3 portas

5 portas

Break

INICIO

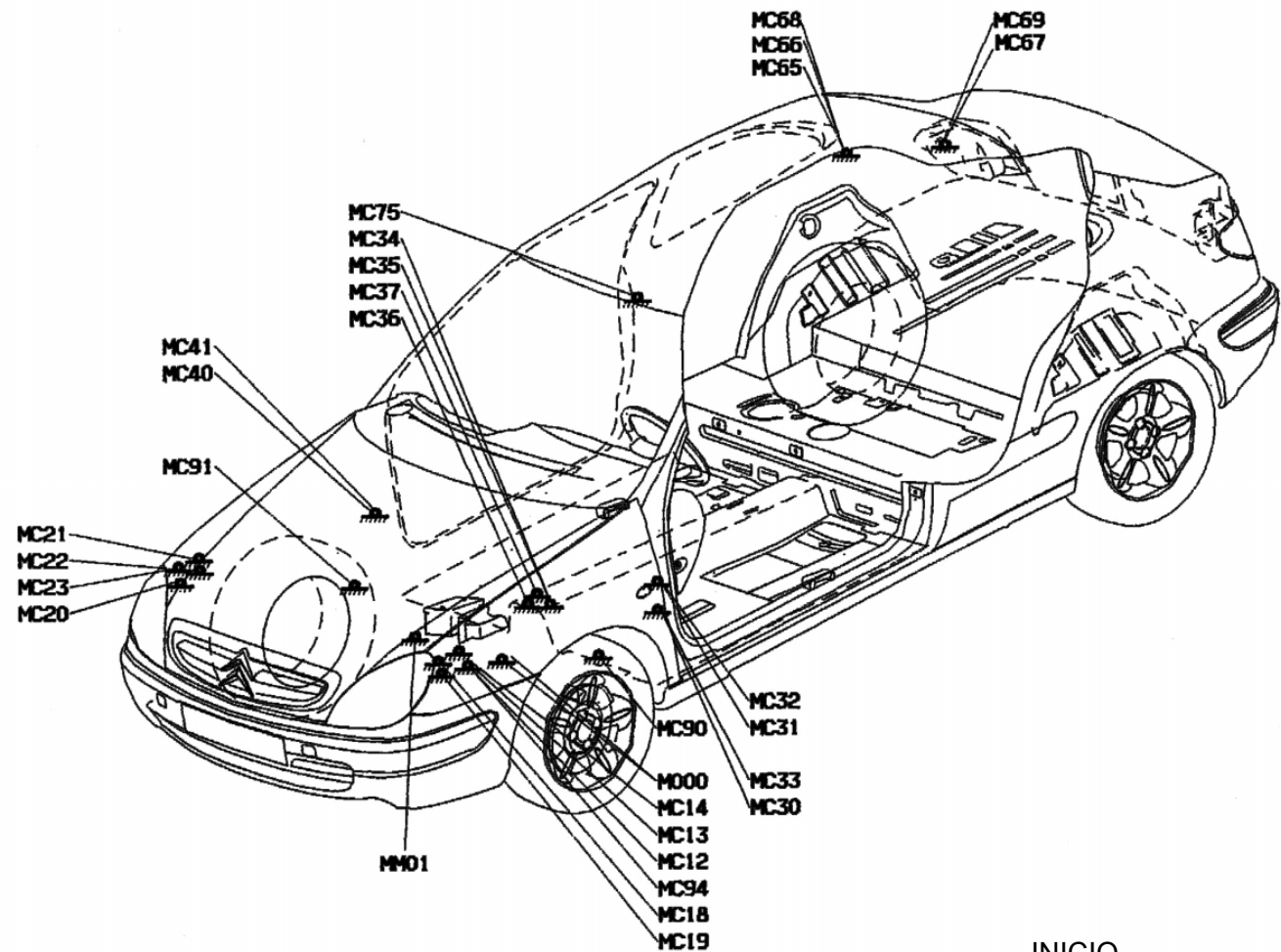

INICIO

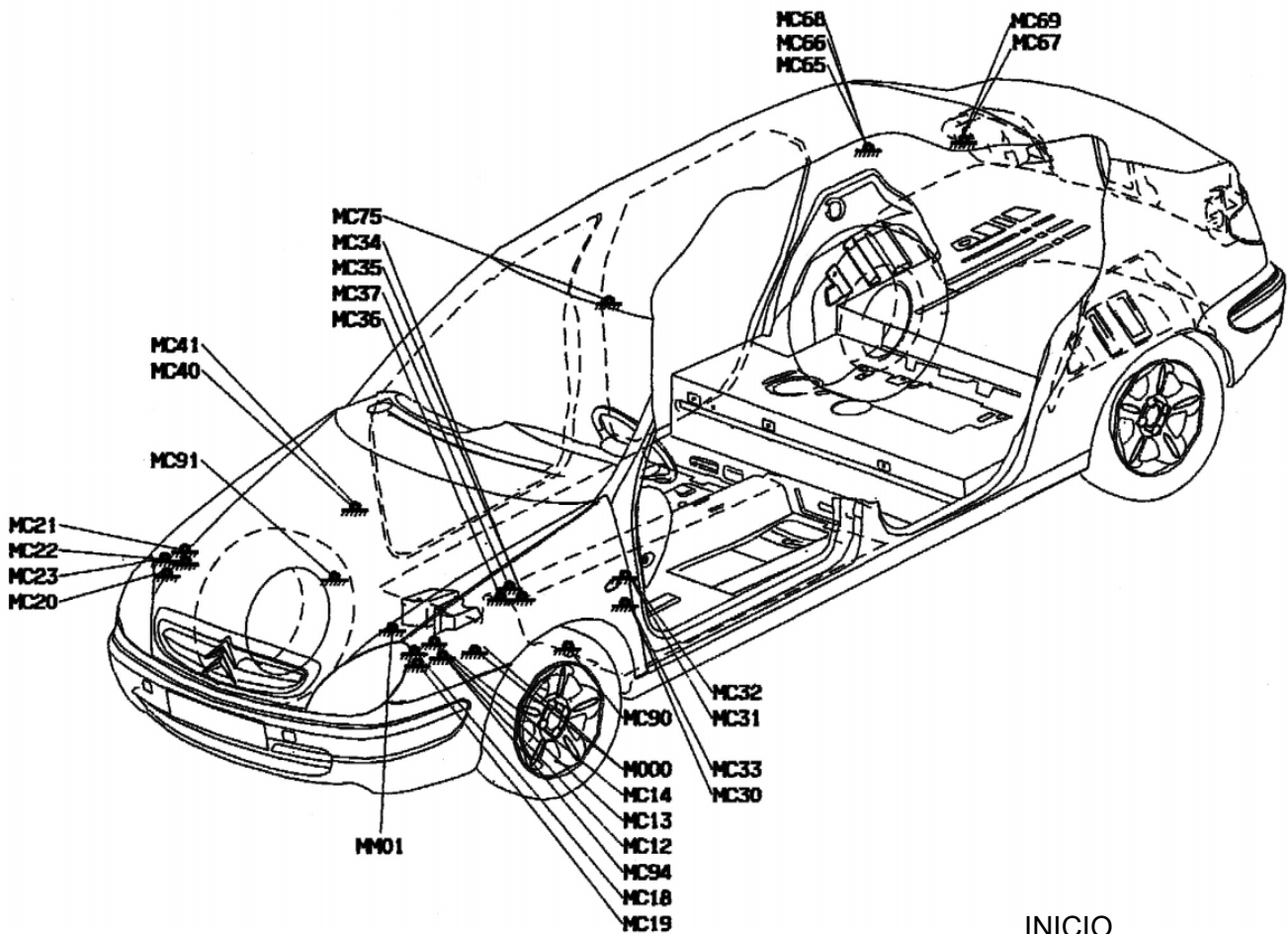

INICIO

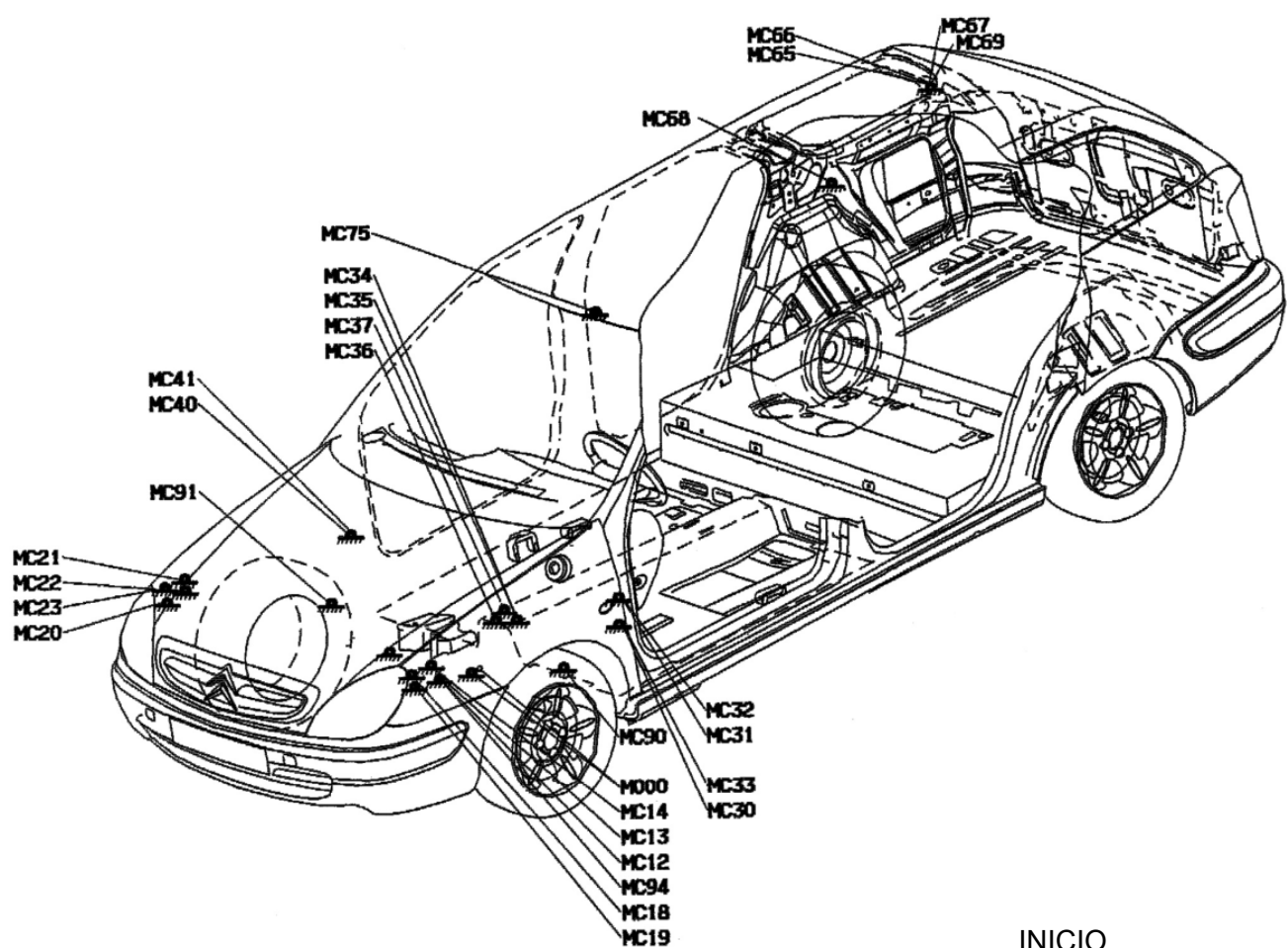

INICIO

Leyenda componentes
0002. Conmutador luces y señalización
0004. Cuadro de instrumentos
0005. Conmutador limpiaparabrisas / luneta trasera térmica
1000. Contactores de seguridad arranque
1005. Relé de prohibición de arrancar
1010. Motor de arranque
1020. Alternador
1025. Caja batería dual
1030. Relé de información motor en marcha
1040. Relé de mantenimiento general
1041. Conmutador parada de urgencia
1042. Relé general
1043. Empujador de rearme
1044. Cajetín diodo
1045. Empujador de rearme auxiliar
1050. Electroválvula mando resistencia calefacción arranque
1086. Relé corte arranque por alarma antirrobo
1100. Distribuidor
1101. Termistancia agua motor para módulo de avance
1102. Módulo de avance
1103. Resistencia electroválvula corrección de avance
1104. Electroválvula corrección de avance
1105. Modulo amplificador de encendido
1110. Distribuidor de encendido
1115. Captador referencia cilindro
1116. Captador referencia cilindro 1.
1117. Captador referencia cilindro 2.
1120. Captador de picado
1121. Captador picado de bielas 1.
1122. Captador picado de bielas 2.
1125. Contactador pedal de acelerador
1127. Relé alimentación encendido
1130. Calculador de encendido
1131. Bobina de encendido cilindro 1
1132. Bobina de encendido cilindro 2
1133. Bobina de encendido cilindro 3.
1134. Bobina de encendido cilindro 4
1135. Bobina de encendido
1136. Condensador de bobina de encendido
1137. Bobina de encendido cilindro 5.
1138. Bobina de encendido cilindro 6.
1140. Módulo antipolución para carburador
1141. Relé de alimentación resistencia 1 calentamiento agua
1142. Relé de alimentación resistencia 2 calentamiento agua
1143. Relé de alimentación resistencia 3 calentamiento agua
1145. Electroválvula apertura mariposa
1146. Relé alimentación resistencia 1/2 calentamiento agua
1147. Relé alimentación resistencia 3/4 calentamiento agua
1148. Relé 1 calentador agua motor
1149. Relé 2 calentador agua motor
1150. Cajetín precalentamiento
1151. Relé para filtro de combustible térmico
1155. Relé precalentamiento

Leyenda Cableados	
00 DIV1	Cableados varios 1
00 DIV2	Cableados varios 2
01 CBP	Cable positivo batería
02 CBN	Cable negativo batería
03 CB/AV	Cable unión batería delantero
04 CB/CE	Cable unión baterías a cofre electrónico
05 CE/MOT	Cable unión cofre electrónico a motor
06 CB/AV/AR	Cable unión baterías delantera y trasera
06 CB/AV/CE	Cable unión baterías central y delantera
06 CB/AR/CE	Cable unión baterías central y trasera
07 FMS	Cable de masa
10 PR	Cableado principal
10 PRC	Cableado principal complementario
11 FD	Cableado luces diurnas
12 US FR	Cableado desgaste pastillas de freno
13 AVERT/S	Cableado bocina
13 AV/D	Cableado delantero derecho
13 AV/G	Cableado delantero izquierdo
14 RG/V	Cableado regulación de velocidad
15 F/AV	Cableado frontal delantero
16 GMC	Cableado grupo motoventilador complementario
16 GMV	Cableado grupo motoventilador
16 P/KD	Cableado prolongador kick-down
17 BR/AV	Cableado antiniebla delantero
17 BR/AV/C	Cableado complementario antiniebla delantero
18 BVA	Cableado caja de velocidades automática
19 BT/EL	Cableado caja electrónica
19 BT/EL/C	Cableado caja electrónica complementaria
20 MOT	Cableado motor
21 PTC	Cableado prolongador térmico
22 MOT/C	Cableado motor complementario
23 BR/HY	Cableado zumbador hidráulico
24 BR/SV	Cableado zumbador sobrevelocidad
25 PCH	Cableado precalentamiento
26 GI	Cableado surtidor térmico
27 EV/AV	Cableado limpiaparabrisas delantero
28 CAPT/PL	Cableado captador de lluvia
30 ABR	Cableado antibloqueo de ruedas
32 SUSP	Cableado suspensión
35 AL	Cableado antirrobo
36 ALA/A	Cableado alarma antirrobo
39 DA	Cableado dirección asistida
43 AE	Cableado autoescuela
43 AEC	Cableado autoescuela complementario
44 CSL	Cableado consola
45 CAPT/VOL	Cableado captador volumétrico
46 HAB	Cableado habitáculo
46 HAC	Cableado habitáculo complementario
46C HCC	Cableado habitáculo complementario (conductor)
46P HCP	Cableado habitáculo complementario (pasajero)
46 PMF	Cableado multifunciones techo
47 ECL V/P	Cableado iluminación guantera
48 PLAF/C	Cableado luz de techo complementario

IC01 interconexión : cableados 10 PR - 50 P/B (3V VE)		
Vía	Nº cable	Designación
1	BM08	alimentación/caja 28 fusibles (habitáculo)
2	BM10	alimentación/conmutador iluminación
3	BM11	alimentación/caja 28 fusibles (habitáculo)

IC01A interconexión : cableados 10 PR - 50 P/B (36V NR) .		
Vía	Nº cable	Designación
1	CC1	alimentación/+ después contacto
2	—	—
3	—	—
4	1593	mando/relé alimentación motoventilador velocidad media
5	441	información nivel líquido de freno
6	410	información presión de aceite
7	6739	información velocidad vehículo
8	8269	información/transpondedor
9	8200	entrada/salida transpondedor
10	403	información/presencia de agua en gasóleo
11	9000C	red CAN H (caja de velocidades automática)
12	9001C	red CAN L (caja de velocidades automática)
13	—	—
14	—	—
15	9007A	diagnóstico - línea L (caja de velocidades automática)
16	9006B	diagnóstico - línea K
17	261	alimentación/luces de posición (izquierda)
18	250A/250B	mando/bocina
19	—	—
20	276A/276B	mando/corrector altura faros
21	—	—
22	8615	alimentación/relé luces de cruce
23	262	alimentación/luces de posición (derecha)
24	402	información/nivel de agua motor
25	210B	información/contactor de stop
26	220	información/luces de marcha atrás
27	531A	mando/bomba lavaluneta trasera
28	511A	mando/bomba lavaparabrisas
29	502	limpiaparabrisas (paro fijo)
30	414	nivel de aceite (señal +)
31	415	nivel de aceite (señal -)
32	1087	excitación alternador
33	4311	interruptor de inercia
34	271	alimentación/luces de cruce izquierda
35	—	—
36	272	alimentación/luces de cruce derecha

IC01B interconexión : cableados 10 PR - 50 P/B (23V MR)		
Vía	Nº cable	Designación
1	1201	mando/bomba de combustible
2	7087	testigo/avería antibloqueo de ruedas
3	7052	diagnóstico/avería antibloqueo de ruedas
4	542	mando/bomba lavafaros
5	205A	mando/relé antiniebla delantero
6	207	testigo antiniebla delantero
7	4441	testigo desgaste pastillas
8	411	logómetro/temperatura aceite motor
9	280C	mando/luces de carretera
10	—	—
11	6770	mando/key-lock (caja de velocidades automática)
12	6742	mando/relé shift-lock (caja de velocidades automática)
13	8060	mando/compresor climatización
14	BH07B	mando relé alimentación/luces de cruce
15	270 F	mando relé alimentación/luces de cruce
16	—	—
17	—	—
18	500	mando/limpiaparabrisas (velocidad lenta)
19	7093	testigo/avería antibloqueo de ruedas
20	288	intermitente (delantero derecho)
21	287	intermitente (delantero izquierdo)
22	501	mando/limpiaparabrisas (velocidad rápida)
23	BM22	alimentación/unidad de servicios inteligente BSI

Codificación de los colores	
BA	Blanco
BE	Azul
BG	Beige
GR	Gris
JN	Amarillo
MR	Marrón
NR	Negro
OR	Naranja
RG	Rojo
RS	Rosa
VE	Verde
VI	Violeta
VJ	Verde/amarillo